

EDF-G1002 Series Quick Installation Guide

Moxa Industrial Next-generation LAN Firewall

Version 2.0, November 2024

Technical Support Contact Information
www.moxa.com/support

MOXA[®]

© 2024 Moxa Inc. All rights reserved.

P/N: 1802010021011



Package Checklist

Before installing your EDF-G1002, verify that the package contains the following items. If any of these items are missing or damaged, please contact your customer service representative for assistance.

- 1 EDF-G1002 industrial next-generation LAN firewall
- 1 USB-C-to-DB9 cable
- Quick installation guide (printed)
- Warranty card

Features

- Bump-in-the-wire installation without impacting the network
- Software-configurable Gen3 LAN Bypass prevents a single point of failure
- Rugged hardware with a -40 to 75°C wide operating temperature range (T model)
- Built-in industrial-grade Intrusion Prevention/Detection System (IPS/IDS)
- Examine industrial protocol data with Deep Packet Inspection (DPI) technology
- Supports secure boot for checking system integrity
- Verify firewall settings with the intelligent Setting Check feature

Installation and Configuration

You will need access to a notebook computer or PC equipped with an Ethernet port. The EDF-G1002 Series has two default IP addresses that allow you to connect to the device for the first time, either through the LAN ports or the Management port.

Take the following steps to configure your EDF-G1002. Refer to the [Panel Layout of the EDF-G1002](#) section below for the location of the ports and sockets.

STEP 1: Connect the EDF-G1002 to a notebook or PC

Since the EDF device supports MDI/MDI-X auto-sensing, you can use either a straight-through or crossover cable to connect the EDF device to a computer. See the [10/100/1000BaseT\(X\) Ethernet Port Connection](#) section for detailed instructions. If the LAN LED indicator on the EDF device lights up, it means a connection has been established.

STEP 2: Set up an IP address for the computer

Set an IP address in the same subnet as the EDF device. The IP and subnet depend on which port is used to connect to the EDF-G1002.

LAN ports: The default IP address of the LAN ports is **192.168.127.254**, with subnet mask **255.255.255.0**. To access the device via the LAN ports, set the IP address of the computer to **192.168.127.xxx** and the subnet mask to **255.255.255.0**.

Management port: The Management port is isolated from the LAN ports. The default IP address of the Management port is **192.168.1.1**, with subnet mask **255.255.255.0**. To access the device via the Management port, set the IP address of the computer to **192.168.1.xxx** and the subnet mask to **255.255.255.0**.

STEP 3: Use the web-based manager to configure the EDF-G1002

Open your computer's web browser and, depending on the port the computer is connected to, type <https://192.168.127.254> (LAN port) or <https://192.168.1.1> (Management port) in the address field to access the homepage of the web-based management system. When prompted, enter the username and password. For first-time configuration, enter the following default username and password:

Username: **admin**

Password: **moxa**

Click **Login**.



ATTENTION

For security reasons, we strongly recommend changing the default password. To change the password, go to **System** → **Account Management** → **User Accounts** and follow the on-screen instructions.

Panel Layout of the EDF-G1002

Front Panel View

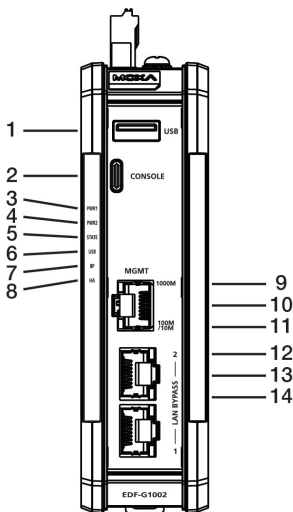

1. USB port for ABC-02-USB
2. Type-C serial console port
3. Power input PWR1 LED indicator
4. Power input PWR2 LED indicator
5. STATE LED indicator
6. USB LED indicator
7. LAN Bypass LED indicator
8. Firewall HA LED indicator
9. 1000 Mbps copper port speed LED indicator for Management port
10. 10/100/1000 Mbps Management copper port
11. 10/100 Mbps copper port speed LED indicator for Management port
12. 1000 Mbps copper port speed LED indicator for LAN ports
13. 10/100/1000 Mbps LAN copper ports
14. 10/100 Mbps copper port speed LED indicator for LAN ports

Top Panel View

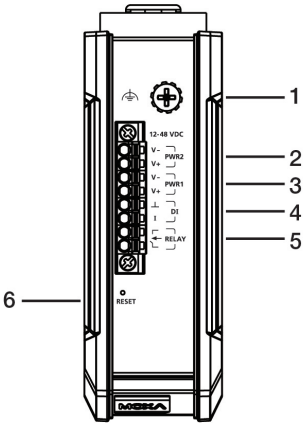

1. Grounding screw
2. Terminal block with latch for Power 2 input
3. Terminal block with latch for Power 1 input
4. Terminal block with latch for digital input
5. Terminal block with latch for relay output
6. Reset button

Rear Panel View

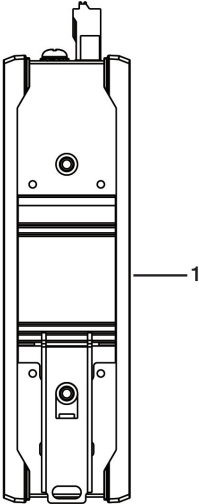

1. DIN-rail mounting kit

Device Dimensions

DIN-rail Dimensions

Unit: mm (inch)

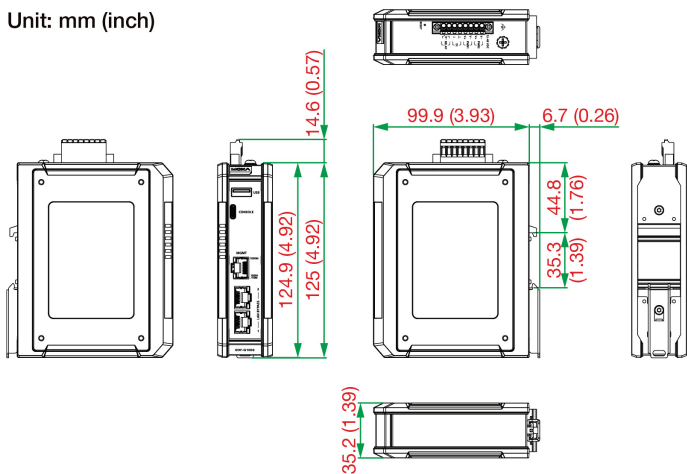

Wall Mounting Dimensions

Unit: mm (inch)

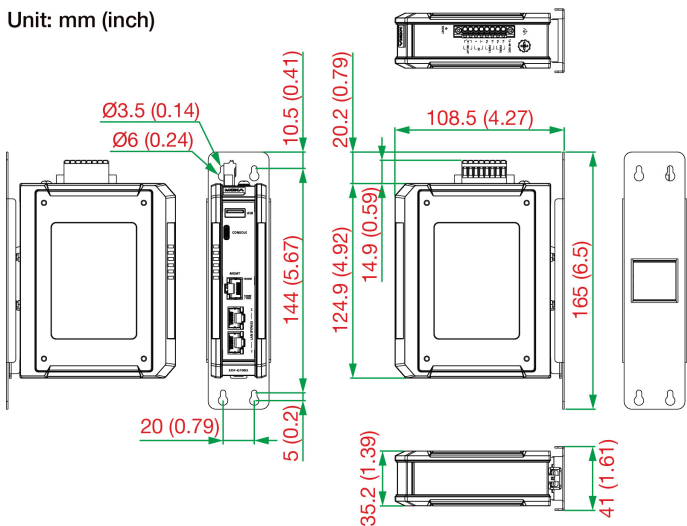

DIN-rail Mounting

The EDF-G1002 Series comes with a DIN-rail kit attached to the back panel by default. Mount the EDF-G1002 Series on a corrosion-free mounting rail that meets the EN 60715 standard.

Installation

STEP 1: Insert the upper lip of the DIN rail into the top hook of the DIN-rail mounting kit.

STEP 2: Press the EDF-G1002 Series towards the DIN rail until it snaps into place.

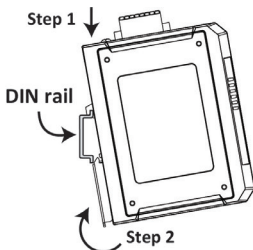

Removal

STEP 1: Pull down the latch on the mounting kit with a screwdriver.

STEP 2: Slightly pull the device forward.

STEP 3: Lift up the device to remove it from the DIN rail.

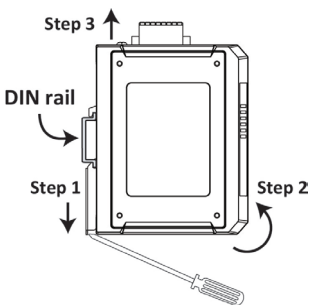

Wall Mounting (optional)

NOTE Mounting the EDF-G1002 Series onto a wall requires the WK-41-01 wall-mounting kit, which is sold separately.

NOTE Confirm the screw head and shaft size are appropriate by inserting the screws into one of the keyhole shaped apertures of the wall-mounting plates before attaching the plates to the wall.

For some applications, it may be more convenient to mount the EDF-G1002 to a wall, as illustrated below.

Installation

STEP 1: Attach the wall-mounting kit to the EDF-G1002 device by inserting the upper lip of the DIN-rail kit into the hook of the wall mounting kit.

STEP 2: Press the EDF-G1002 device towards the wall mounting kit until it snaps into place.

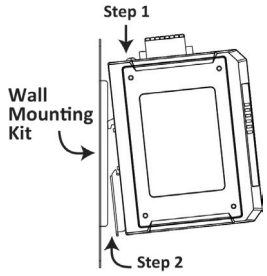

STEP 3: Verify that the assembled device fits in the intended installation location with the wall-mounting kit and all attachments by holding the device to the intended installation position. Mark this space with a pencil.

STEP 4: Remove the wall-mounting kit from the device hold it to the marked space, mark the screw holes, and attach the screws.

NOTE Attaching the Mounting the EDF-G1002 device to a wall requires 4 screws. To ensure stable mounting, the head of the screws should be less than 6.0 mm in diameter, and the shaft should be at least 3.5 mm in diameter. The length of the 3.5 mm screws should be at least 10 mm.

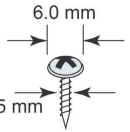

STEP 5:

Once the screws are fixed into the wall, insert the four screw heads through the large opening of the keyhole-shaped apertures of the mounting kit, and then slide the EDF-G1002 device downwards. Tighten the four screws for added stability.

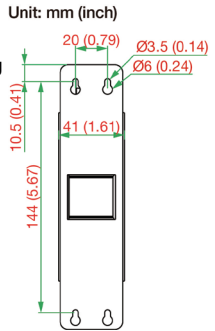

Removal

STEP 1: Pull down the latch on the mounting kit with a screwdriver.

STEP 2: Slightly pull the device forward.

STEP 3: Lift up the device to detach it from the wall.

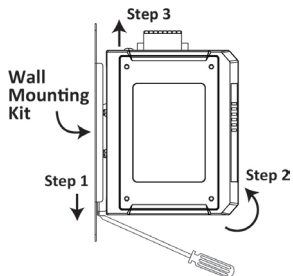



WARNING

- This equipment is intended to be used in a Restricted Access Location, such as a dedicated computer room, where access can only be gained by SERVICE PERSONS or by USERS who have been instructed about the fact that the metal chassis of the equipment is extremely hot and may cause burns.
- Service persons or users should pay special attention and take special precautions before handling this equipment.
- Only authorized, well-trained professionals should be allowed to access the restricted access location. Access should be controlled by the authority responsible for the location with lock and key or a security identity system.
- **External Metal Parts are Hot!!** Pay special attention or use special protection before handling this equipment.

Wiring Requirements



WARNING

Safety First!

Be sure to disconnect the power cord before installing and/or wiring the EDF device.

Read and Follow These Guidelines

NOTE Do not run signal or communications wiring and power wiring in the same wire conduit. To avoid interference, wires with different signal characteristics should be routed separately.

- Use separate paths to route wiring for power and devices. If power wiring and device wiring paths must cross, make sure the wires are perpendicular at the intersection point.
- You can use the type of signal transmitted through a wire to determine which wires should be kept separate. The rule of thumb is that wiring with similar electrical characteristics can be bundled together.
- Keep input wiring and output wiring separate.
- It is strongly advised that you label wiring to all devices in the system when necessary.



ATTENTION

The equipment is intended to be supplied by an external power source (Single or Dual input for Redundant Power Input) (UL listed / IEC 60950-1 / IEC 62368-1) with output compliant with ES1 (SELV for IEC 60950-1), supporting an output rating 12-48 VDC, 0.69 A minimum, and a minimum ambient temperature of 75 °C.

Grounding the Moxa EDF-G1002 Series

Grounding and wire routing help limit the effects of noise due to electromagnetic interference (EMI) by routing the noise from the metal chassis to the connected ground. Run the ground connection from the ground screw to the grounding surface prior to connecting devices. The minimum cross-sectional area of the grounding conductor should be equal to that of the input cable. The grounding screw (M4 type) is located near the power connector.



ATTENTION

This product is intended to be mounted on a well-grounded mounting surface, such as a metal panel. The potential difference between the two ground potentials must be zero. If the potential difference is NOT zero, the product could be permanently damaged.

Connecting the Power Input



ATTENTION

Before connecting the EDF-G1002 to the DC power inputs, make sure that the DC power source voltage is stable.

STEP 1: Use a small flat-blade screwdriver to press the wire locker.

STEP 2: Insert a positive/negative DC wire into the V+/V- terminals respectively.

STEP 3: Release the wire locker and confirm the wire is fixed in place.

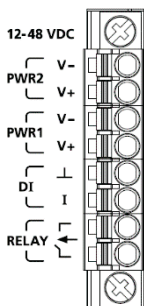

- NOTE**
- The input terminal block wiring should be done by a skilled professional.
 - Wire type: Cu
 - Only use 16-20 AWG wire sizes.
 - Each clamping point can only have one conductor.
 - When using a Class I adapter, the power cord should be connected to an outlet with an earthing connection.

Communication Connections

10/100/1000Base-T(X) Ethernet Port Connection

The 10/100/1000Base-T(X) ports located on the front panel of the EDF device are used to connect to Ethernet-enabled devices.

Pinouts for both MDI (NIC-type) ports and MDI-X (HUB/Switch-type) ports are shown below:

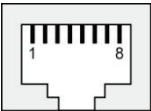
MDI Port Pinouts		MDI-X Port Pinouts		8-pin RJ45
Pin	Signal	Pin	Signal	
1	Tx+	1	Rx+	
2	Tx-	2	Rx-	
3	Rx+	3	Tx+	
6	Rx-	6	Tx-	

Console Port

The EDF-G1002 Series features a Type-C console port for connecting to a PC COM port using a Type-C-to-DB9 cable. You can use this port for debugging or firmware upgrades.

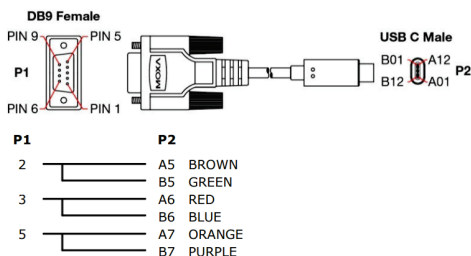

Description	P1	P2
TXD	2	A5, B5
RXD	3	A6, B6
GND	5	A7, B7

USB

The EDF device is equipped with a type-A USB 2.0 port, which can only be used to connect an ABC-02-USB storage tool.

LED Indicators

The LED indicators are located on the side panel of the EDF-G1002. The function of each LED is described in the table below:

LED	Color	Behavior	Function
PWR1	Amber	On	Power is being supplied to power input PWR1.
	Off	Off	Power is not being supplied to the power PWR1.
PWR2	Amber	On	Power is being supplied to power input PWR2.
	Off	Off	Power is not being supplied to the power PWR2.

LED	Color	Behavior	Function
STATE	Green	On	The system passed the self-diagnosis test during boot-up and is ready to run.
		Blinking (1 Hz)	The system is ready to do a factory reset after pressing the reset button for 5 seconds.
	Red	On	The system failed the self-diagnosis test during boot-up.
	Off	Off	The system is off.
USB	Green	On	A USB device is connected.
		Blinking (1 sec off, 1 sec on)	USB data is being transmitted.
	Red	On	The USB device is malfunctioning.
	Off	Off	No USB device connected.
Bypass	Amber	On	System-halted bypass or Run-time bypass mode is enabled.
		Blinking (0.5 Hz)	Run-time bypass is enabled and operating
	Off	Off	System-halted bypass or Run-time bypass mode is disabled.
HA	Green	On	Reserved.
	Amber	On	Reserved.
	Off	Off	Reserved.
10/100/1000 Mbps	Green	On	The port is active, and a link is established at 1000 Mbps.
		Blinking	Data is being transmitted at 1000 Mbps.
	Amber	On	The port is active, and a link is established at 10/100 Mbps.
		Blinking	Data is being transmitted at 10/100 Mbps.
	Off	Off	The port is inactive, or the link is down.



Specifications

Input Current	0.69 A (max.)
Input Voltage	12 to 48 VDC
Power Consumption	8.3 W (max.)
Digital Input	+13 to + 30 VDC for state 1 -30 to +3 VDC for state 0
Operating Temperature	Standard Models: -10 to 60°C (14 to 140°F) Wide Temp. Models: -40 to 75°C (-40 to 167°F)
Storage Temperature	-40 to 85°C (-40 to 185°F)
Safe Compass Distance	200 mm



WARNING

사 용 자 안 내 문 이 기기는 업무용 환경에서 사용할 목적으로 적합성 평가를 받은 기기로서 가정용 환경에서 사용하는 경우 전파간섭의 우려가 있습니다.

Model/Rating	Model name: EDF-G1002-BP EDF-G1002-BP-T EDF-G1002-BP-CT EDF-G1002-BP-CT-T Rating: 12 to 48 VDC, 0.69 A (max.) Relay output: 24 VDC, 1 A
ATEX information	  II 3G Ex ec nC IIC T4 Gc UL 24 ATEX 3248X Ambient Range: $-40\text{ }^{\circ}\text{C} \leq T_{amb} \leq +75\text{ }^{\circ}\text{C}$ for models suffix with "-T" Ambient Range: $-10\text{ }^{\circ}\text{C} \leq T_{amb} \leq +60\text{ }^{\circ}\text{C}$ for models suffix without "-T" Rated Cable Temp $\geq 106.1\text{ }^{\circ}\text{C}$
IECEX Certificate No.:	IECEX UL 24.0051X
Address of manufacturer	No. 1111, Heping Rd., Bade Dist., Taoyuan City 334004, Taiwan

Special Use Conditions

- The equipment shall be installed in an enclosure that provides a minimum ingress protection of IP54 in accordance with IEC 60079-0 and only accessible by use of a tool.
- The equipment shall only be used in an area of at least pollution degree 2, as defined in EN 60664-1.