

V1200 Series Hardware User's Manual

Version 1.0, February 2025

www.moxa.com/products

MOXA®

© 2025 Moxa Inc. All rights reserved.

V1200 Series Hardware User's Manual

The software described in this manual is furnished under a license agreement and may be used only in accordance with the terms of that agreement.

Copyright Notice

© 2025 Moxa Inc. All rights reserved.

Trademarks

The MOXA logo is a registered trademark of Moxa Inc.
All other trademarks or registered marks in this manual belong to their respective manufacturers.

Disclaimer

- Information in this document is subject to change without notice and does not represent a commitment on the part of Moxa.
- Moxa provides this document as is, without warranty of any kind, either expressed or implied, including, but not limited to, its particular purpose. Moxa reserves the right to make improvements and/or changes to this manual, or to the products and/or the programs described in this manual, at any time.
- Information provided in this manual is intended to be accurate and reliable. However, Moxa assumes no responsibility for its use, or for any infringements on the rights of third parties that may result from its use.
- This product might include unintentional technical or typographical errors. Changes are periodically made to the information herein to correct such errors, and these changes are incorporated into new editions of the publication.

Technical Support Contact Information

www.moxa.com/support

Table of Contents

1. Introduction	4
Package Checklist	4
Product Features	4
Product Specifications	4
2. Hardware Introduction	5
Appearance	5
V1202-CT-T	5
V1222-CT-T	5
V1222-W-CT-T	6
Dimensions	6
Wall Mounting (default)	6
Desk Mounting (optional)	7
DIN-rail Mounting (optional)	7
LED Indicators	8
Installation Options	8
Wall Mounting (default)	8
Desk Mounting (optional)	9
DIN-rail Mounting (optional)	10
3. Hardware Connection Description	11
Wiring Requirements	11
Connecting the Power	12
Grounding the Computer	12
Connecting the Network	13
Connecting a USB Device	13
Connecting Serial Ports	14
Inserting the SIM Card	14
Inserting a MicroSD Card	15
Connecting the Console Port	15
A. Regulatory Approval Statements	16

1. Introduction

The V1200 computing platform is designed for railway TCMS data-acquisition and train-to-ground applications.

The computer comes with dual M12 10/100/1000 Mbps Ethernet ports, built-in 5G and Wi-Fi 6 modules and dual RS-232/422/485 serial ports.

The slim, compact design with multiple mounting options reduces installation space and provides flexibility for mounting in various cabinets or onboard locations.

Each unit is equipped with Moxa Industrial Linux (MIL) for long-term Linux support and vulnerability patching. A web-based interface is provided for easy configuration of Ethernet and wireless network settings without the need for programming.

The wireless enabled models are thoroughly tested in a testing chamber, guaranteeing that the wireless-enabled computing platforms meet EN50155 OT4 requirements and are suitable for wide-temperature applications.

Package Checklist

Before installing a V1200 computer, verify that the package contains the following items:

- 1 x V1200 Series computer
- 1 x Wall-mounting kit
- 1 x Quick installation guide (printed)
- 1 x Warranty card (printed)



NOTE

Notify your sales representative if any of the above items are missing or damaged.

Product Features

- Arm Cortex-A53 quad-core 1.6 GHz processor
- Integrated 5G Sub-6GHz NR module and Wi-Fi 6 module with dual SIM
- Slim, compact design with multiple mounting options
- Isolated power with 24 to 110 VDC power supply range
- TPM 2.0 built-in and developed according to the IEC 62443-4-1 and security features referencing IEC 62443-4-2 industrial cybersecurity standards.*
- Moxa Industrial Linux built-in for long-term Linux support
- Meet EN 50155 OT4 operating temperature (-40 to 70°C with cellular and Wi-Fi modules enabled)

* IEC-62443-4-2 SL2 referencing features to be released in 2026 Q1.

Product Specifications



NOTE

The latest specifications for Moxa's products can be found at <https://www.moxa.com>.

2. Hardware Introduction

The V1200 computer is compact and designed to be rugged enough for industrial applications. This chapter provides information on the appearance and dimensions of the V1200 and describes the LED indicators that can help you monitor system performance and identify issues. The multiple installation options allow you to find the most suitable installation method for your site and ensure the correct installation of computer.

Appearance

V1202-CT-T

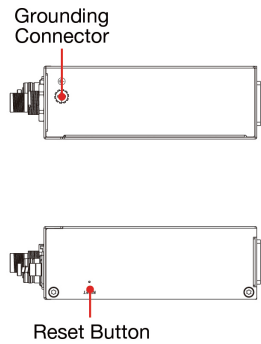
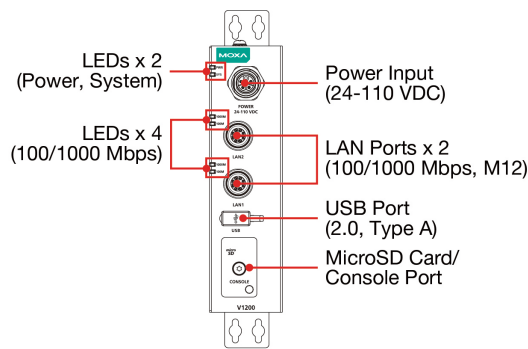

V1222-CT-T

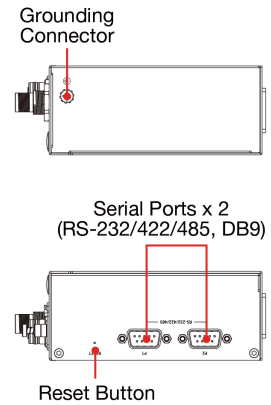
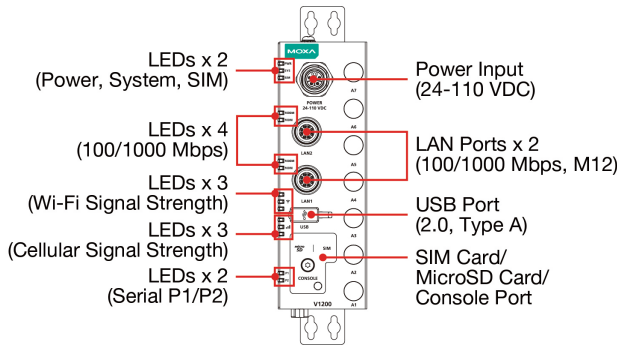

V1222-W-CT-T

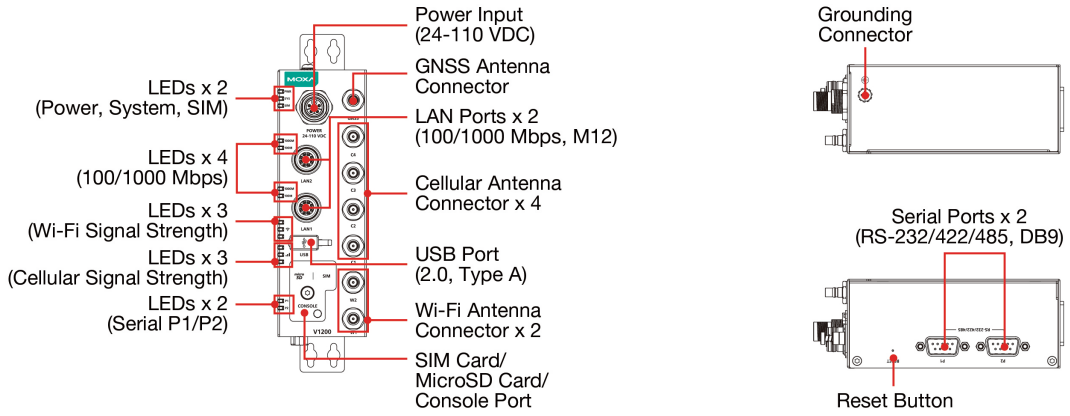

Dimensions

Wall Mounting (default)

Unit: mm

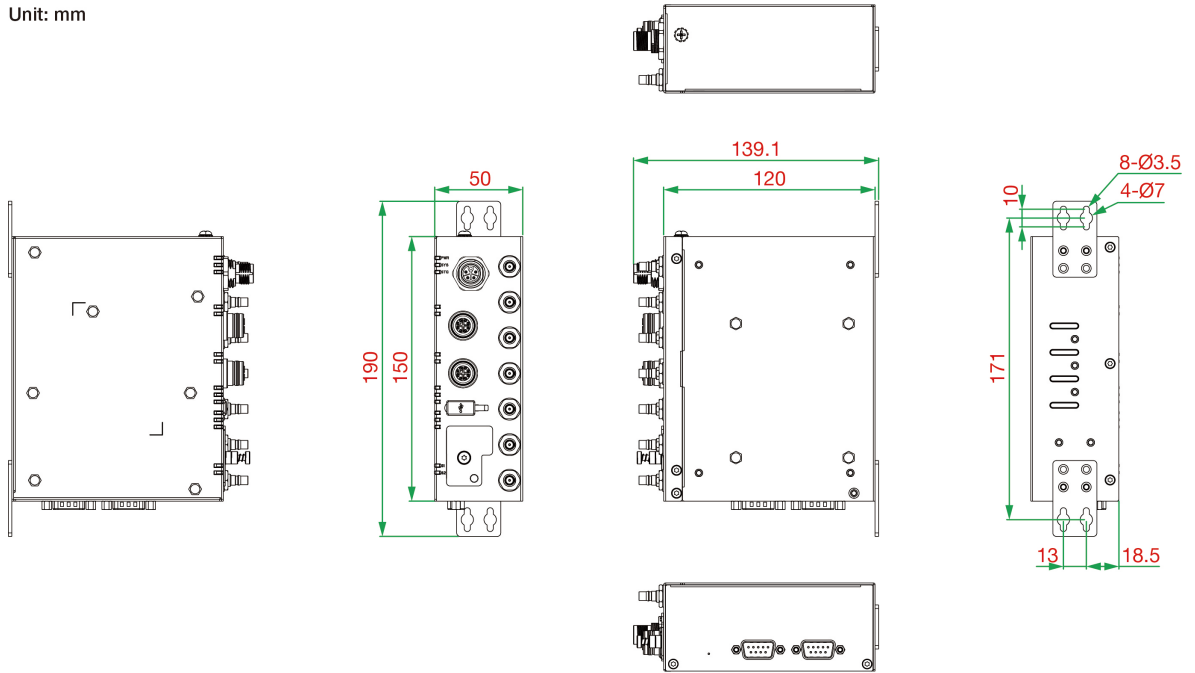

Desk Mounting (optional)

Unit: mm

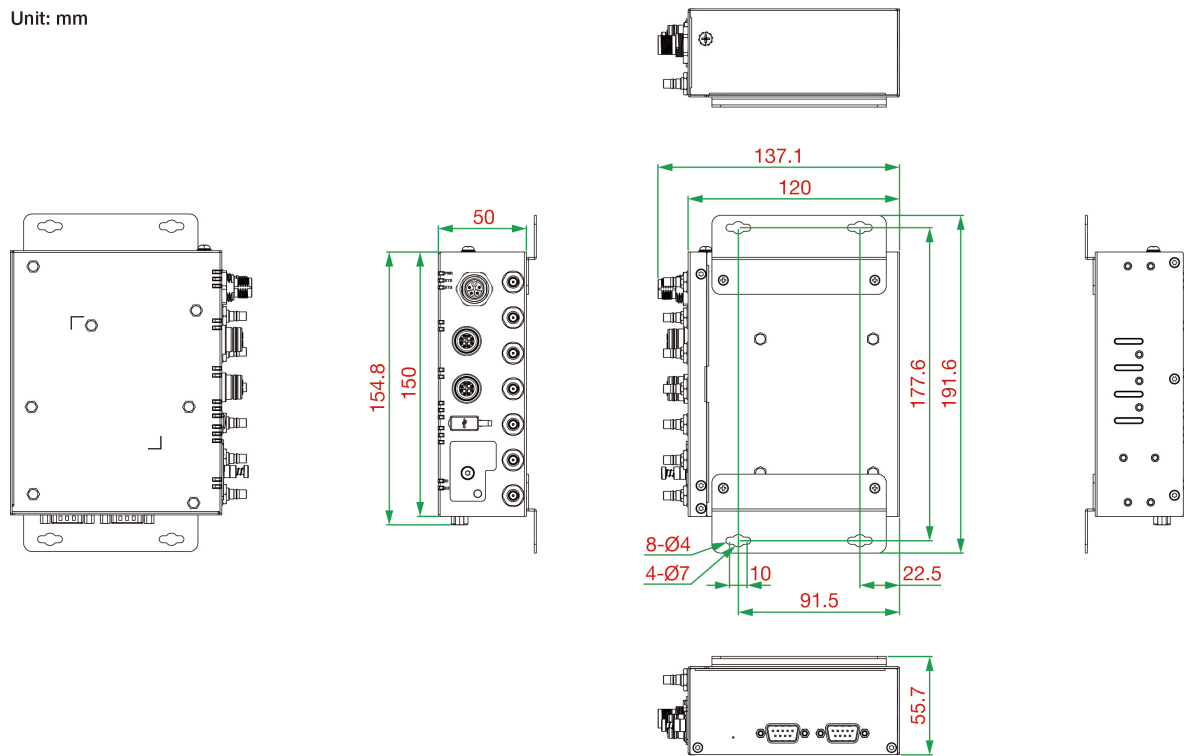

DIN-rail Mounting (optional)

Unit: mm

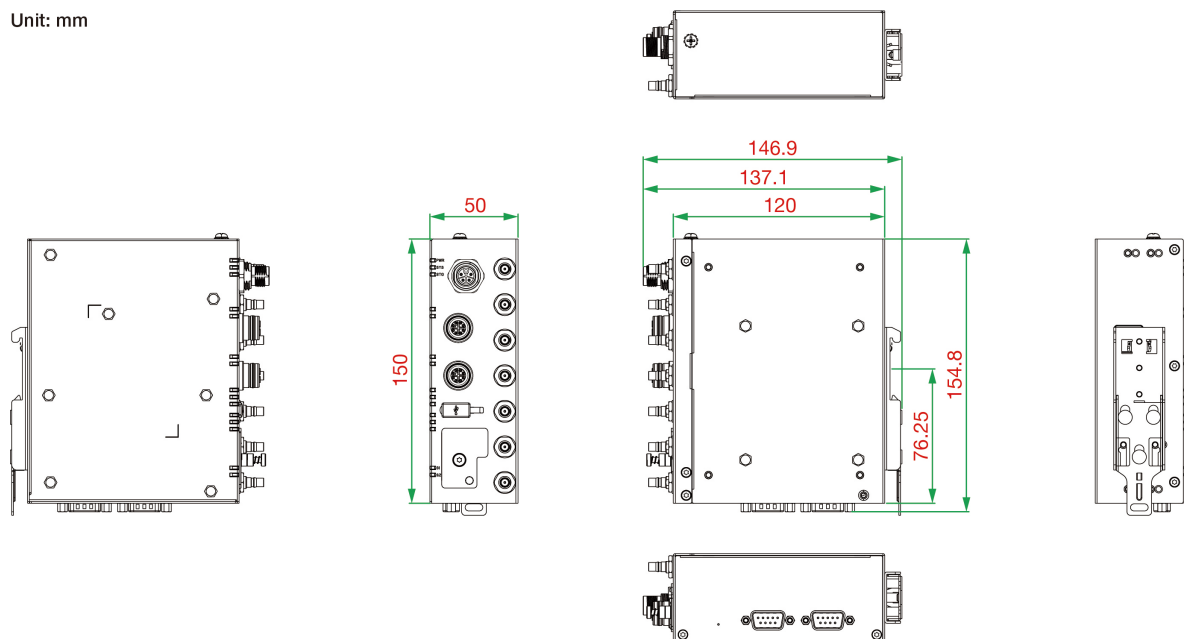

LED Indicators

The function of each LED is described in the table below:

LED Name	Color	LED Status	Description
PWR	Green	Steady on	Power is on
	Off	Off	No power
SYS	Green	Steady on	Device has booted successfully (all system services are initialized)
	Green	Blinking	Device is in the process of booting up
	Red	Steady on	Device boot up failed (one or more system services failed to initialize)
	Off	Off	The device is still in the bootloader stage; is not booted into the kernel yet
LAN	Green	Steady on	100 Mbps Ethernet link
		Blinking	Data is being transmitted or received
	Yellow	Steady on	1000 Mbps Ethernet link
		Blinking	Data is being transmitted or received
	Off	Off	The Ethernet cable is disconnected

Installation Options



NOTE

For IP40 compliance, the cover of the SD card, SIM card, and console port, should be secured properly with screws.

Ensure that the USB port is covered with the rubber cap if it is not in use.

The V1200 Series can be mounted on to a DIN rail, a wall, or installed on a desk. The wall-mounting kit is included in the product package by default. If you want to use another mounting method, you will need to order the optional DIN-rail mounting or desk-mounting kits separately. Contact a Moxa sales representative to place an order.

Wall Mounting (default)

The wall-mounting kit is included in the product package by default. To attach the wall-mounting brackets, first align them to the apertures on the back panel of the V1200 and fasten the four M3 screws (torque value of 4.5 ± 0.5 kgf-cm) included in the package to secure the mounting brackets.

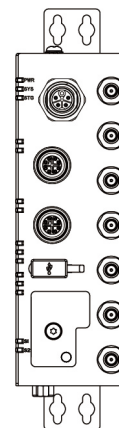
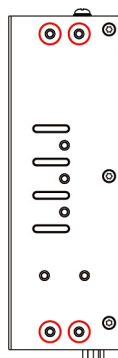

To mount the V1200 on to a wall, use four M3 x 6 mm screws and a torque value of 4.5 ± 0.5 kgf-cm. See *Additional Screws for Wall and Desk Mounting*.

Desk Mounting (optional)

Step 1

Use the four screws (M3 x 5 mm) in the package to fasten the wall-mounting brackets to the computer.

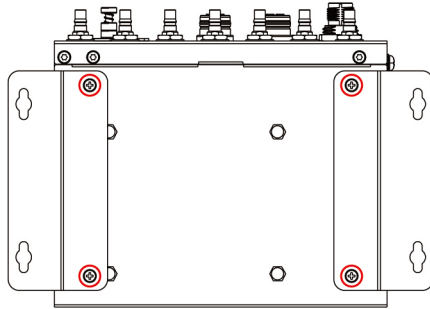

Step 2

Use another four screws (M3 x 6 mm) to mount the computer on to a wall or in a cabinet.

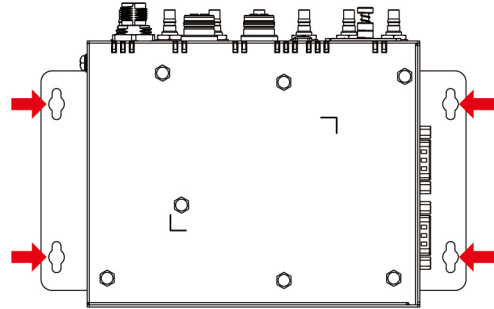

To fix the V1200 on to a desk, use four M3 x 6 mm screws and a torque value of 4.5 ± 0.5 kgf-cm. See *Additional Screws for Wall and Desk Mounting*.



NOTE

- Test the screw head and shank size by inserting the screws into one of the keyhole shaped apertures of the wall-mounting plates before attaching the plate to the wall.
- Do not drive the screws in all the way—leave a space of about 2 mm to allow room for sliding the wall mount panel between the wall and the screws.

Additional Screws for Wall and Desk Mounting

You will require additional screw for mounting the V1200 with the mounting brackets on to a wall or a desk. These screws are not included in the mounting kit package and must be purchased separately. The specifications of the additional screws required are as follows:

Head Type: Pan/Dome

Head Diameter $5.2 \text{ mm} < OD < 7.0 \text{ mm}$

Length $> 6 \text{ mm}$

Thread Size: M3 x 0.5P

Recommended Fastening Torque: 4.5 ± 0.5 kgf-cm

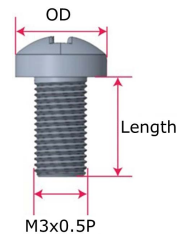

DIN-rail Mounting (optional)

The DIN-rail mounting kit is an optional accessory not included in the product package and needs to be purchased separately.

To attach the DIN-rail mounting bracket to the computer, align the mounting bracket to the mounting apertures on the back panel of the computer. Fasten the five M3 x 4 mm screws in the mounting-kit package to secure the bracket to the computer with a torque value of 4.5 ± 0.5 kgf-cm.

To mount the V1200 Series on to a DIN rail, ensure that the stiff metal spring is facing upwards and follow these steps.

1. Pull down the slider of the DIN-rail bracket located at the back of the unit.
2. Insert the top of the DIN rail into the slot just below the upper hook of the DIN-rail bracket.
3. Latch the unit firmly on to the DIN rail as shown in the illustrations below.
4. Once the computer is mounted properly, you will hear a click and the slider will rebound back into place automatically.

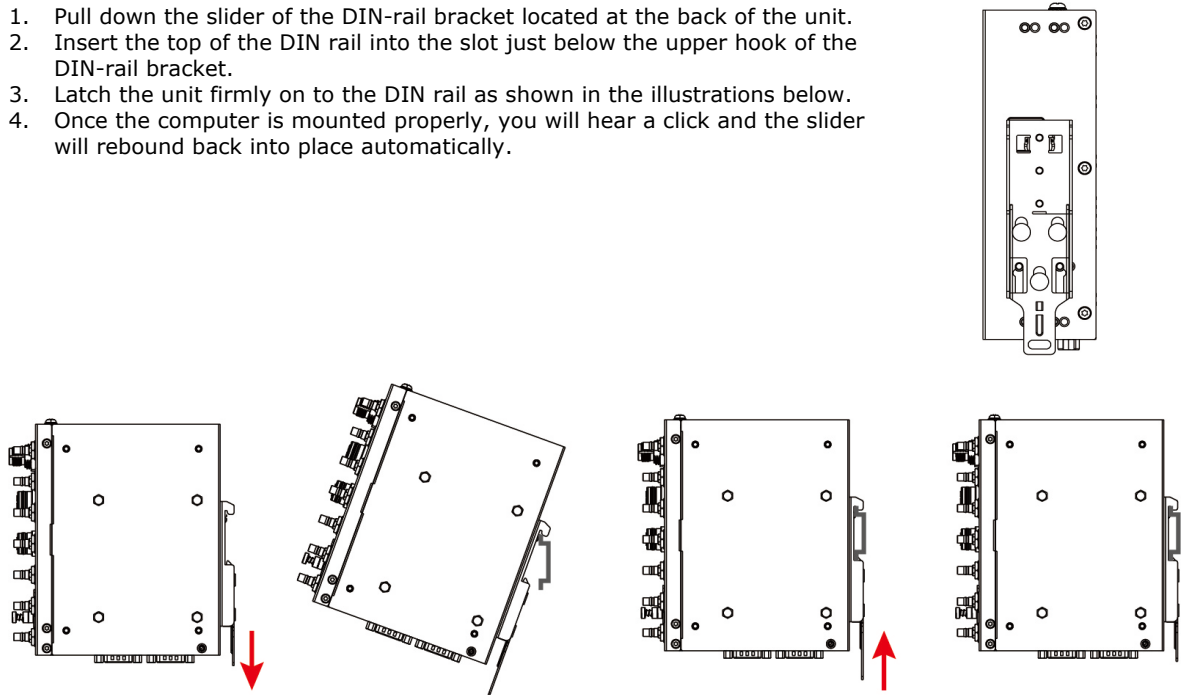

3. Hardware Connection Description

In this chapter, we describe how to connect the V1200 to a network and various devices.

Wiring Requirements

In this section, we describe how to connect various devices to the embedded computer. Be sure to read and follow these common safety precautions before proceeding with the installation of any electronic device:

- Use separate paths to route wiring for power and devices. If power wiring and device wiring paths must cross, make sure the wires are perpendicular at the intersection point.



NOTE

Do not run signal or communication wiring and power wiring in the same wire conduit. To avoid interference, wires with different signal characteristics should be routed separately.

- You can use the type of signal transmitted through a wire to determine which wires should be kept separate. The rule of thumb is that wiring that shares similar electrical characteristics can be bundled together.
- Keep input wiring and output wiring separate.
- When necessary, it is strongly advised that you label wiring to all devices in the system.



ATTENTION

Safety First!

Be sure to disconnect the power cord before doing installations and/or wiring.

Electrical Current Caution!

Calculate the maximum possible current in each power wire and common wire. Observe all electrical codes dictating the maximum current allowable for each wire size.

If the current goes above the maximum ratings, the wiring could overheat, causing serious damage to your equipment.

Temperature Caution!

Be careful when handling the unit. When the unit is plugged in, the internal components generate heat, and consequently the outer casing may feel hot to the touch.

Connecting the Power

Connect the 24 to 110 VDC power line with M12 K-coded connector (needs to be purchased separately) to the V1200 computer. If the power is supplied properly, the "PWR" LED will glow a solid green after a 25 to 30-second delay. The power input location and pin definition are shown in the following figures:

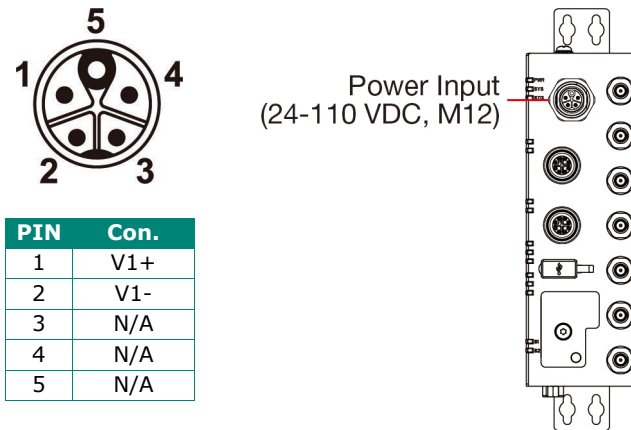

Grounding the Computer

There is a grounding connector located on the top panel of the computer. Grounding and wire routing help limit the effects of noise due to electromagnetic interference (EMI). Note that this product is intended to be mounted on a well-grounded mounting surface, such as a metal panel.

The power cord adapter should be connected to a socket outlet with an earthing connection.

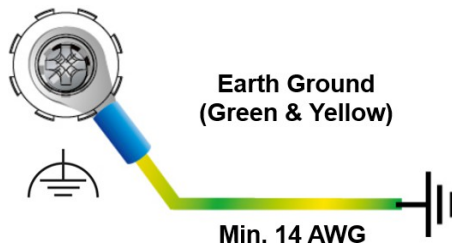

ATTENTION

This product is intended to be mounted to a well-grounded mounting surface such as a metal panel. Use the green-and-yellow cable type minimum with American Wire Gauge (AWG) 14 (2.5 mm²) for grounding.

Connecting the Network

The pin assignments for the V1200 computer's Ethernet ports are shown in the following figure. If you are using your own Ethernet cable, make sure that you match the pin assignment on the connector of the Ethernet cable to the pin assignment shown below:

PIN	Definition
1	DA+
2	DA-
3	DB+
4	DB-
5	DD+
6	DD-
7	DC-
8	DC+

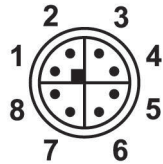

LAN Ports x 2
(100/1000 Mbps, M12)

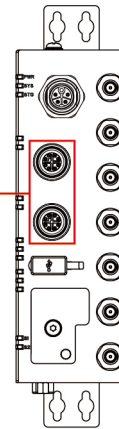

Connecting a USB Device

The USB port, located on the front panel, is a type-A USB 2.0 console port which you can use to connect a USB storage device or a type-A USB compatible device.

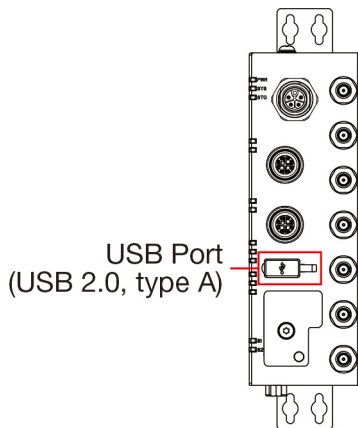

Connecting Serial Ports

The computer comes with two serial ports on the bottom panel. Use a serial cable to connect your serial device to the computer via a serial port. The serial ports use DB9 connector and can be configured for RS-232, RS-422, or RS-485 communication. The location and pin assignments of the serial ports are shown in the following tables:

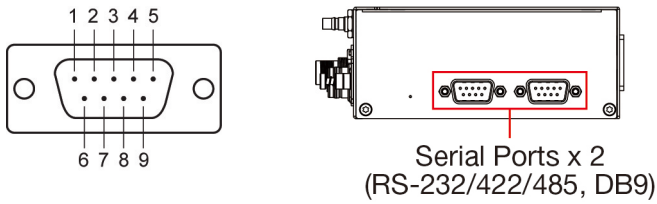

Pin	RS-232	RS-422	RS-485 (4-wire)	RS-485 (2-wire)
1	DCD	TxDA(-)	TxDA(-)	-
2	RxD	TxDB(+)	TxDB(+)	-
3	TxD	RxDB(+)	RxDB(+)	DataB(+)
4	DTR	RxDA(-)	RxDA(-)	DataA(-)
5	GND	GND	GND	GND
6	DSR	-	-	-
7	RTS	-	-	-
8	CTS	-	-	-

Inserting the SIM Card

The V1200 models come with 1 or 2 SIM card slots on the front panel. When you install the SIM cards into the slots, ensure that they are inserted in the correct direction, as indicated on the label.

To install a SIM card, do the following:

Step 1

Remove the screw securing the SIM card holder cover on the front panel of the computer.

Step 2

Remove the SIM card tray by pressing the tray inwards and releasing it to eject the tray, then pulling out the tray.

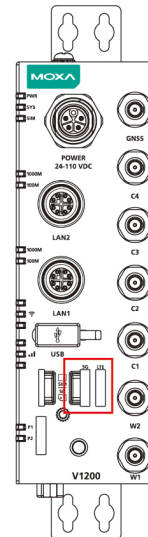
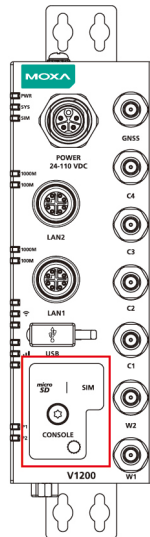

Step 3

The SIM card tray can hold two SIM cards, one on each side. Install the first SIM card in the SIM1 slot and the second SIM card on the other side of the tray.

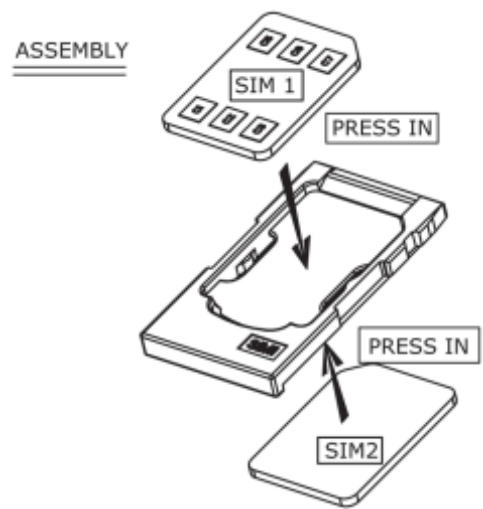

Inserting a MicroSD Card

The V1200 comes with a microSD socket for storage expansion. The microSD socket is located on the lower part of the front panel. To install the card, remove the screw and the protection cover to access the socket, and then insert the microSD card into the socket. You will hear a click when the card is in place. To remove the card, push the card in before releasing it.

Connecting the Console Port

The console port is an RS-232 port located on the lower part of the front panel. To install the card, remove the screw and the protection cover to access the console port. Connect a 4-pin pin header cable and use the port for debugging issues or system image upgrades.

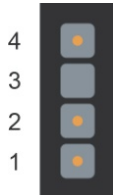

Pin	Signal
1	TxD
2	RxD
3	NC
4	GND

A. Regulatory Approval Statements

FCC Statement

This equipment has been tested and found to comply with the limits for a Class A digital device, pursuant to part 15 of the FCC Rules. These limits are designed to provide reasonable protection against harmful interference when the equipment is operated in a commercial environment. This equipment generates, uses, and can radiate radio frequency energy and, if not installed and used in accordance with the instruction manual, may cause harmful interference to radio communications. Operation of this equipment in a residential area is likely to cause harmful interference in which case the user will be required to correct the interference at his own expense.

Any changes or modifications not expressly approved by the party responsible for compliance could void the user's authority to operate this equipment.

This equipment complies with FCC radiation exposure limits set forth for an uncontrolled environment. This equipment should be installed and operated at a minimum distance of 20 cm between the radiator and your body.

This device and its antenna must not be co-located or operating with any other antenna or transmitter.



WARNING

This is a class A product. In a domestic environment, this product may cause radio interference in which case the user may be required to take adequate measures.
