

# DA-920E Series Hardware User Manual

---

Version 1.0, June 2026

[www.moxa.com/products](http://www.moxa.com/products)

**MOXA**®

© 2026 Moxa Inc. All rights reserved.

# DA-920E Series Hardware User Manual

The software described in this manual is furnished under a license agreement and may be used only in accordance with the terms of that agreement.

## Copyright Notice

© 2026 Moxa Inc. All rights reserved.

## Trademarks

The MOXA logo is a registered trademark of Moxa Inc.  
All other trademarks or registered marks in this manual belong to their respective manufacturers.

## Disclaimer

- Information in this document is subject to change without notice and does not represent a commitment on the part of Moxa.
- Moxa provides this document as is, without warranty of any kind, either expressed or implied, including, but not limited to, its particular purpose. Moxa reserves the right to make improvements and/or changes to this manual, or to the products and/or the programs described in this manual, at any time.
- Information provided in this manual is intended to be accurate and reliable. However, Moxa assumes no responsibility for its use, or for any infringements on the rights of third parties that may result from its use.
- This product might include unintentional technical or typographical errors. Changes are periodically made to the information herein to correct such errors, and these changes are incorporated into new editions of the publication.

## Technical Support Contact Information

[www.moxa.com/support](http://www.moxa.com/support)

# Table of Contents

<b>1. Introduction .....</b>	<b>4</b>
Overview .....	4
Package Checklist .....	4
Model Descriptions .....	5
Appearance.....	5
Front View.....	5
Rear View.....	6
Dimensions .....	6
Features .....	7
Hardware Block Diagram .....	7
Hardware Specifications .....	7
<b>2. Hardware Installation.....</b>	<b>8</b>
Mounting the DA-920E on to a Rack.....	8
Wiring Requirements.....	9
Connecting the Power .....	10
Wiring the Power Inputs.....	10
Reset Button .....	12
LED Indicators.....	12
Connecting Displays.....	13
Connecting USB Devices .....	14
Serial Ports .....	14
Gigabit LAN Ports.....	14
Relay Output.....	15
Installing Storage Disks.....	15
Installing the M.2 Storage Module.....	17
Installing the Memory Module.....	18
Installing Expansion Modules.....	19
Hardware Security and Installing Locks .....	20
Ventilation .....	21
RTC Battery .....	22
<b>3. BIOS Setup .....</b>	<b>23</b>
Entering the BIOS Setup.....	23
Main Page.....	25
Advanced Settings .....	25
Boot Configuration.....	26
SATA Configuration .....	27
CPU Configuration .....	29
PCH-IO Configuration.....	30
Socket Configuration .....	31
Processor Configuration .....	32
CPU C State Control.....	33
H2O IPMI Configuration.....	34
H2O Redfish Configuration.....	35
NVM Express Information .....	36
Security Settings .....	37
Set Supervisor Password .....	38
Power Settings .....	40
Boot Settings .....	41
Exit Settings .....	43
Administering Secure Boot.....	44
Enabling UEFI Secure Boot .....	45
Enroll EFI Image .....	46
Enroll Customer Key .....	47
Upgrading the BIOS .....	48

# 1. Introduction

---

Thank you for purchasing a Moxa DA-920E industrial computer, a multi-functional embedded computer designed especially for IEC 61850-3 substation automation systems.

This manual covers hardware installation, connector interfaces, and BIOS setup of the DA-920E. For software configuration and management, please refer to the user's manual for your operating system.

## Overview

The DA-920E is a 2U rack mountable, fanless industrial server built for harsh environments, virtualized protection, automation, and control (vPAC), and substation automation. The computer is compliant with IEC 61850-3, IEEE 1613, and IEC 60255 requirements. Powered by Intel® Xeon® D processor with up to 256 GB ECC memory, the DA-920E delivers high-performance, deterministic reliability, and is optimized for virtualization applications. With single or dual wide-range PSUs and RAID storage, the DA-920E ensures reliable computing in modern substations.

## Package Checklist

Each model ships with following additional items:

- DA-920E rackmount computer
- Rack-mounting kit
- USB dongle kit
- 1 or 2 terminal blocks for the power supply
- 1 terminal block for the COM port
- 1 terminal block for the relay output
- A pack of thermal pads for the M.2 storage and memory modules
- A pack of 4 backup screws for memory modules
- A pack of 16 screws for mounting the SSD
- Quick Installation Guide
- Warranty card



### NOTE

Notify your sales representative if any of the above items are missing or damaged.

# Model Descriptions

The DA-920E Series includes the following models:

- **DA-920E-X08-H:** IEC 61850-3 2U rackmount computer with Intel® Xeon® D-1834 processor, 8P/16T core, 1 DA-PWR-200-HV power module, -25 to 55°C operating temperature
- **DA-920E-X08-HH:** IEC 61850-3 2U rackmount computer with Intel® Xeon® D-1834 processor, 8P/16T core, 2 DA-PWR-200-HV power modules, -25 to 55°C operating temperature
- **DA-920E-X08-W:** IEC 61850-3 2U rackmount computer with Intel® Xeon® D-1834 processor, 8P/16T core, 1 DA-PWR-200-WV power module, -25 to 55°C operating temperature
- **DA-920E-X08-WW:** IEC 61850-3 2U rackmount computer with Intel® Xeon® D-1834 processor, 8P/16T core, 2 DA-PWR-200-WV power modules, -25 to 55°C operating temperature
- **DA-920E-X08-HW:** IEC 61850-3 2U rackmount computer with Intel® Xeon® D-1834 processor, 8P/16T core, 1 DA-PWR-200-HV, 1 DA-PWR-200-WV power modules, -25 to 55°C operating temperature

## Power Modules

- **DA-PWR-200-HV:** 100-240 VAC/VDC, hot-swappable power module
- **DA-PWR-200-WV:** 24-110 VDC, hot-swappable power module

## Passive Ventilation Kit (purchase separately)

- **DA-PVK-LP:** Passive ventilation kit for the low-profile PCIe expansion slots

# Appearance

## Front View

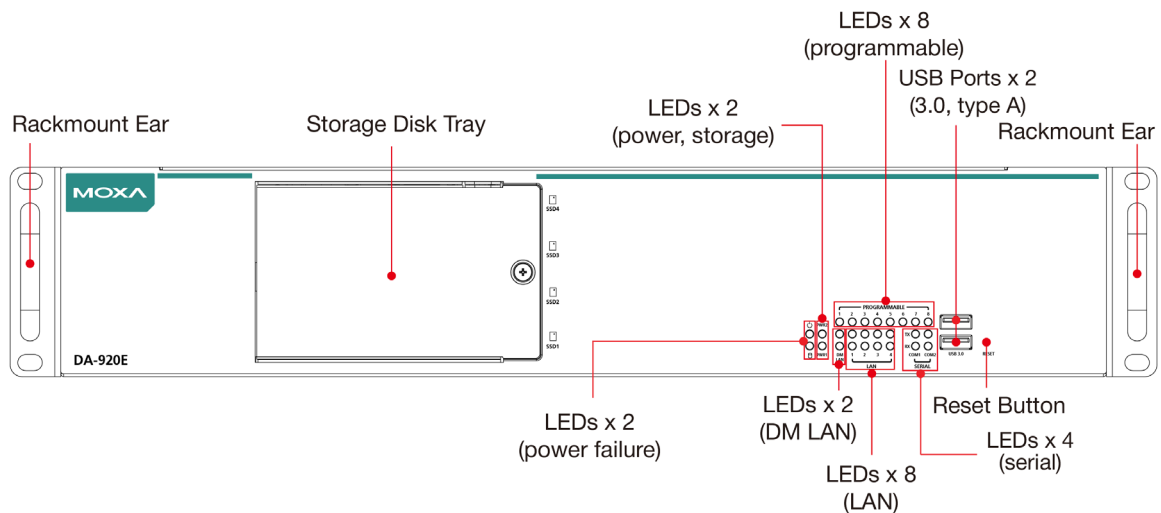

# Rear View

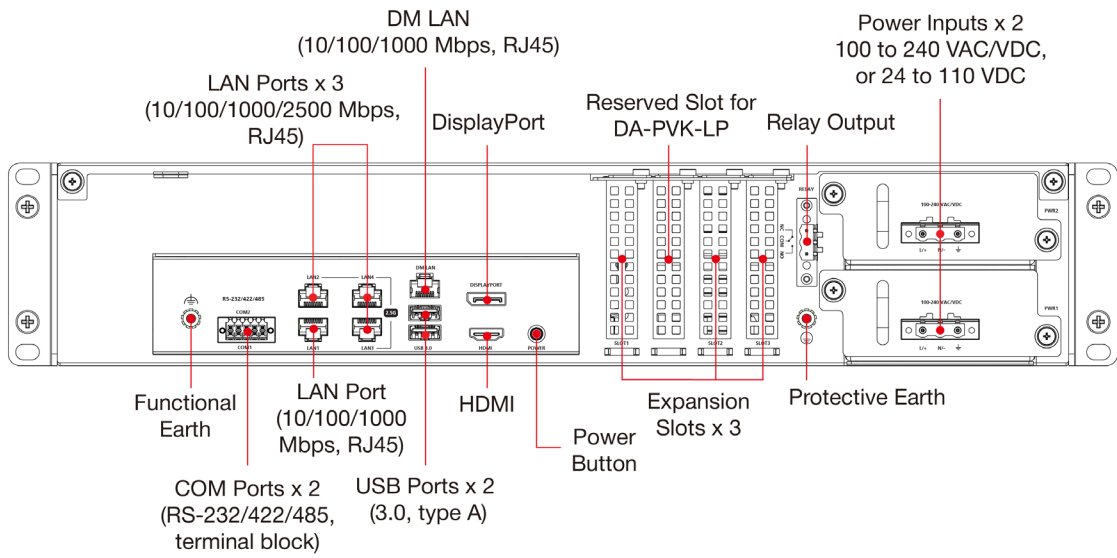

# Dimensions

Unit: mm (inch)

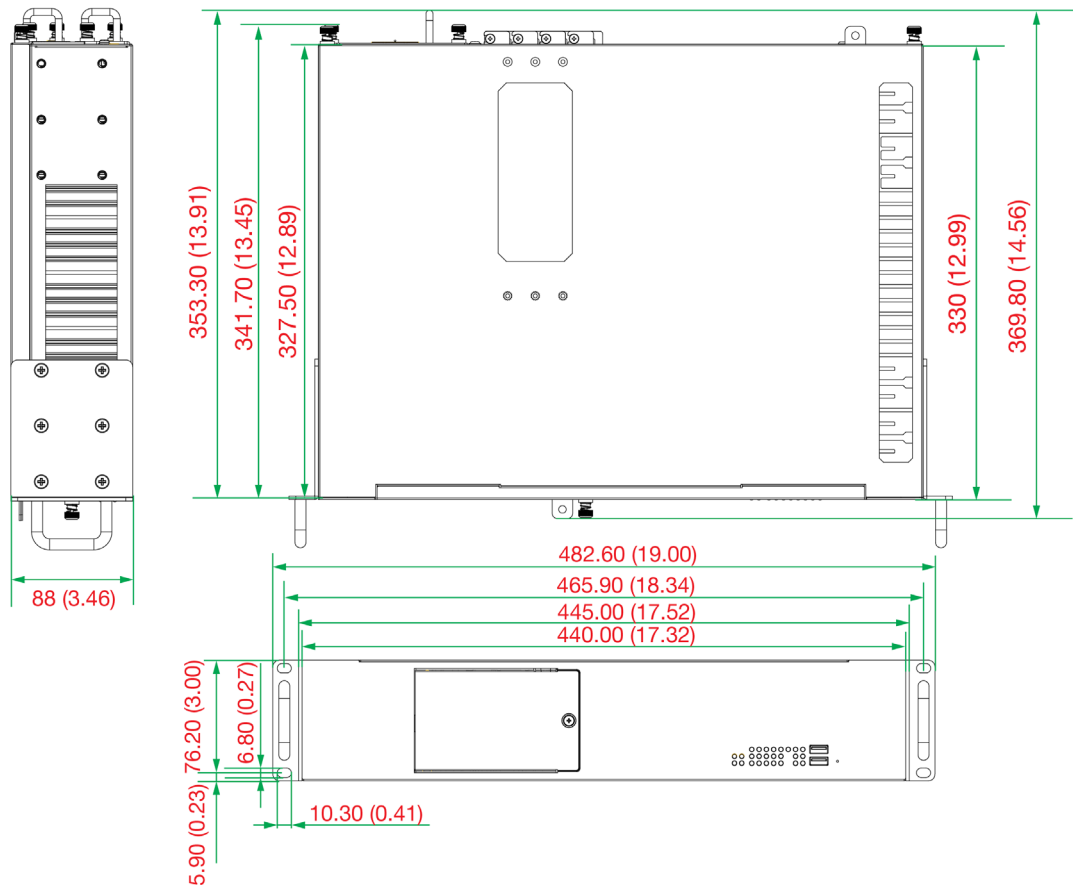
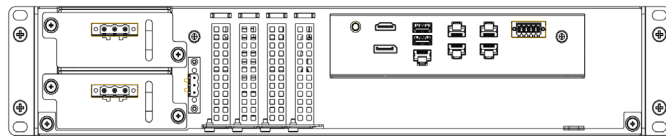

# Features

The DA-920E computer has the following features:

- IEC 61850-3, IEEE 1613, and IEC 60255 compliant power-automation server
- EN 50121-4 compliant for railway wayside applications
- Intel® Xeon® D-1834 processor
- Up to 256 GB RAM (4 built-in RDIMM DDR4 memory slots)
- 4 SSD slots with Intel® RAID 0/1/5/10 support
- 1 PCIe x16, 1 PCIe x8, and 1 PCIe x4 slots for expansion modules
- Security options such as TPM 2.0, UEFI Secure Boot and physical security
- -25 to 55°C operating temperature

## Hardware Block Diagram

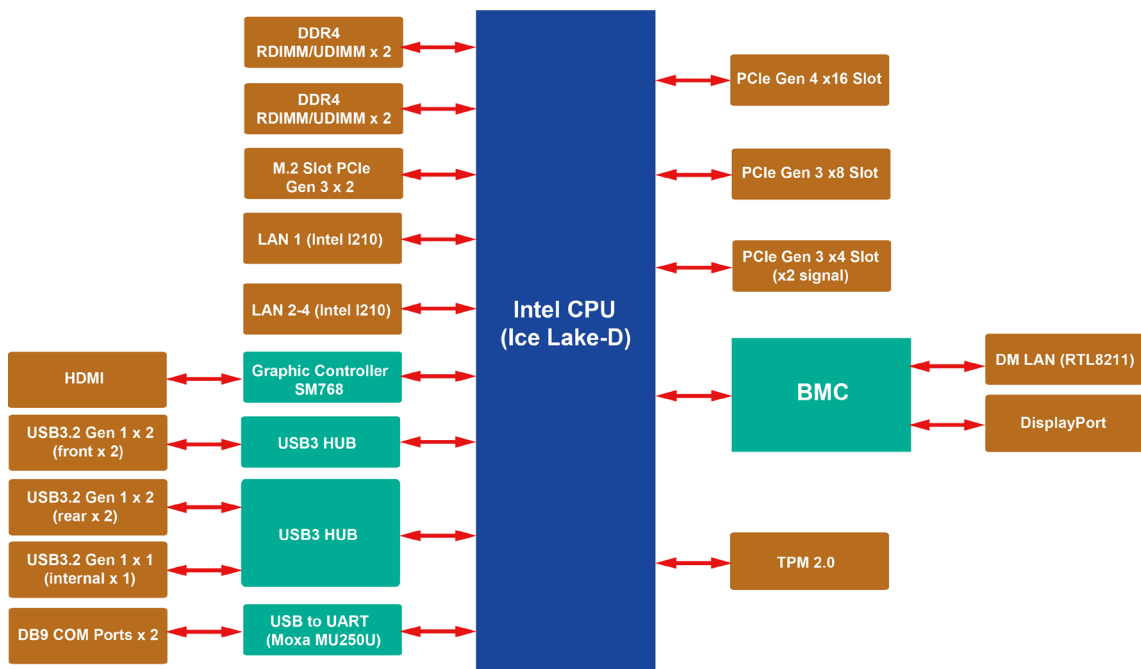

## Hardware Specifications



### NOTE

The latest specifications for Moxa's products can be found at <https://moxa.com>.

## 2. Hardware Installation

This chapter describes the hardware installation and connector interfaces of the DA-920E embedded computers.

### Mounting the DA-920E on to a Rack

The DA-920E comes with a rack-mounting kit that includes two rackmount ears and twelve screws.

To attach the rackmount ears to the DA-920E, place a rackmount ear on one side of the front-panel and secure it using 6 screws (included in the package) as shown in the following image. Attach the other mounting ear on the other side of the front panel in a similar manner.

You can choose either the front-mounting or rear-mounting method to mount the computer.

#### **Front Mounting**



#### **Rear Mounting**

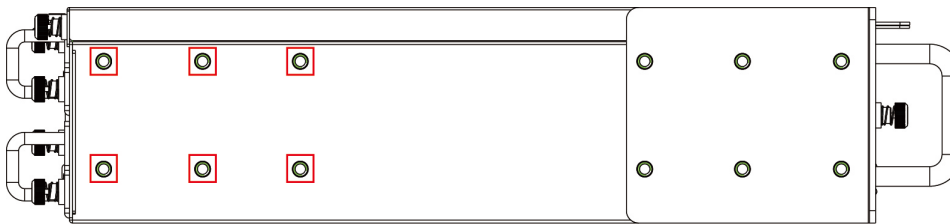

The twelve screws included in the package are of the following specifications:

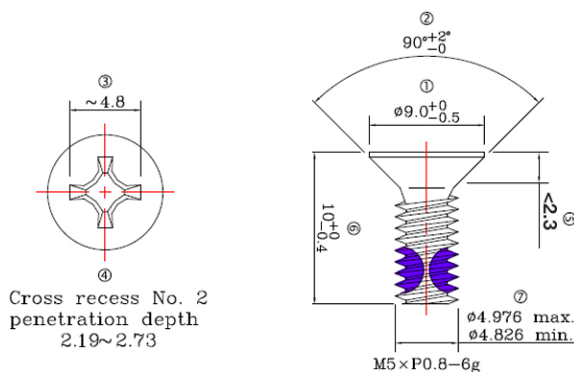

# Wiring Requirements

The following common safety precautions should be observed before installing any electronic device:

- Power wires and communication/signal wires should be routed through separate paths. If power and communication/signal wires must cross paths, make sure the wires are perpendicular at the intersection point.



## NOTE

Do not run signal or communication wiring and power wiring in the same wire conduit. To avoid interference, wires with different signal characteristics should be routed separately.

- Use the type of signal transmitted through a wire to determine which wires should be bundled together and which should be kept separate. The rule of thumb is that wiring that carries similar electrical signals can be bundled together.
- When necessary, we strongly advise labeling the wiring for all devices in the system.



## ATTENTION

### Safety First!

Be sure to disconnect the power cord before installing and/or wiring your device.

### Electrical Current Caution!

Calculate the maximum possible current in each power wire and common wire. Observe all electrical codes dictating the maximum current allowable for each wire size.

If the current goes above the maximum rating, the wiring could overheat, causing serious damage to your equipment.



## ATTENTION

### Restricted Access Location

This equipment is intended to be used in Restricted Access Locations, such as a computer room, where access can only be gained by SERVICE PERSONS or by USERS who are instructed about the metal chassis of the equipment being hot and to pay special attention or take special protection before touching it. Further, access should be by a key or security identity system. Only authorized well-trained professionals can access the restricted access location.



## ATTENTION



### Hot Surfaces

External metal parts are hot!! Before touching it, special attention or protection is necessary.

# Connecting the Power

The DA-920E features dual power inputs via a terminal block located on the rear panel. To establish a power connection, attach the power cord wires to the corresponding screws and secure them. Upon successful power connection, the Power LED will illuminate indicating that power is being supplied to the DA-920E. Subsequently, the PLED 1 (Programmable LED 1) will turn green for 20 seconds and then turn off. The BIOS will initialize the flash disk module, resulting in the storage LED blinking. The operating system boot-up process typically takes between 3 to 4 minutes to complete. The rear panel is equipped with a power button for powering the computer on from sleep or hibernate mode.

Model/Power Modules	DA-PWR-200-HV	DA-PWR-200-WV
DA-920E-X08-H	1	-
DA-920E-X08-HH	2	-
DA-920E-X08-HW	1	1
DA-920E-X08-W	-	1
DA-920E-X08-WW	-	2



## ATTENTION

Before connecting the DA-920E computer to an AC/DC power source, ensure that the AC/DC power source voltage is stable.

The wiring for the input terminal block shall be installed by qualified and experienced professionals and use the following:

- Wire type: Cu, FW2
- Wire gauge: 16 to 12 AWG 1.5 to 4 mm<sup>2</sup>)
- Recommended torque: 5.0 kg-cm (4.34 lb-in)

Use only one conductor per clamping point between the AC power source and the power input. amping point between the AC power source and the power input.

## Wiring the Power Inputs

To establish a power connection, insert the power cord wires in the correct terminals and tighten the screws to secure the wires. Refer to the following diagrams and table for a detailed description of the power input wiring terminals.



## NOTE

The PWR1/PWR2 LEDs on the front panel will turn on if the computer loses power. For details on power LED behavior, refer to the *LED Indicators* section.

## Installing/removing the Hot-swappable Power Supply

To install the hot-swappable power supply, insert it into either the PWR1 or PWR2 slot. Ensure that it is inserted all the way to the end of the slot. Secure the power supply by fastening screws on both sides.

To remove the power supply, first unfasten the two screws. Then, grasp the handle of the power supply and gently pull it out of the slot.



### NOTE

Check the screws on Power 1 and Power 2 after inserting them into the slot. Make sure they are been firmly fastened for a secure installation.

#### Power Supply: DA-PWR-200-HV, DA-PWR-200-WV

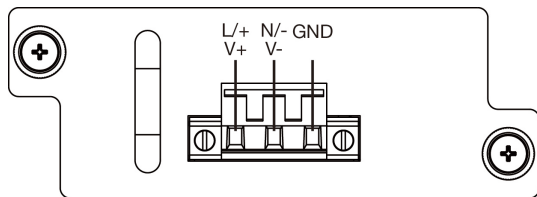

Terminal Number	Description
L/+	PWR line
N/-	PWR Neutral
GND	Ground

## Grounding the Chassis

A protective earth (PE) grounding connector is located on the rear panel of the DA-920E computer.

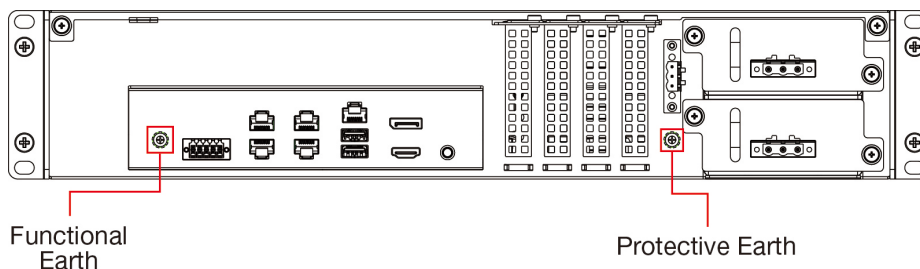

Connect the chassis grounding connector to the PE connector, which in turn must be connected to the earth ground using the green and yellow grounding wire as shown in the following figure:

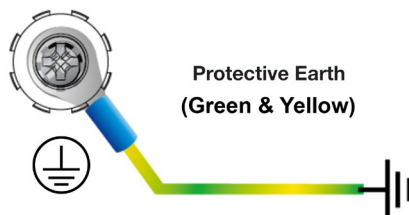

### ATTENTION

If protective earthing is used as a safeguard, the instructions shall require the connection of the equipment protective earthing conductor to the installation protective earthing conductor (for example, using a power cord connected to a socket-outlet with an earthing connection).

The grounding cable should be of the following specifications:

- Wire gauge: 16 to 12 AWG (1.5 to 4 mm<sup>2</sup>)
- Recommended torque: 5.0 kg-cm (4.34 lb-in)

# Reset Button

Pressing the Reset button initiates a hardware warm reboot. After pressing the reset button, the system will reboot automatically. During normal use, you should NOT use the Reset Button. You should only use this button if the software is not working properly. To protect the integrity of data being transmitted or processed, you should always reset the system from the operating system with the software reboot function.

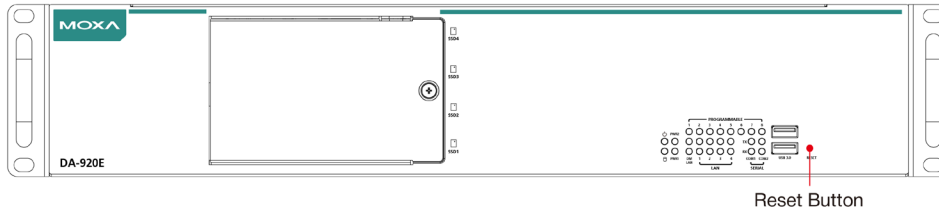

# LED Indicators

Information about each LED indicator is listed in the following table:

LED	Status	Function	
Power	Green	Power is on	
	Off	No power	
Storage	Yellow	Blinking	Data is being written to or read from the storage
	Off	No activity	
PWR1	Off	The first power supply is operational	
	Red	Error in the first power supply	
PWR2	Off	The second power supply is operational	
	Red	Error in the 2nd power supply (only applicable to models with dual power supplies)	
LAN 1 (shared LAN)	Green	Steady on	10/100 Mbps Ethernet link
		Blinking	Data is being transmitted or received
	Yellow	Steady on	1000 Mbps Ethernet link
		Blinking	Data is being transmitted or received
Off	No Ethernet connection		
LAN 2 to 4	Green	Steady on	10/100/1000 Mbps Ethernet link
		Blinking	Data is being transmitted or received
	Yellow	Steady on	2500 Mbps Ethernet link
		Blinking	Data is being transmitted or received
Off	No Ethernet connection		
LAN DM (dedicated management LAN)	Green	Steady on	10/100 Mbps Ethernet link
		Blinking	Data is being transmitted or received
	Yellow	Steady on	1000 Mbps Ethernet link
		Blinking	Data is being transmitted or received
Off	No Ethernet connection		
Serial Port P1/P2	Green	Tx: Serial data is being transmitted	
	Yellow	Rx: Serial data is being received	
Programmable LEDs 1 to 8	Green	Steady on	Can be used to indicate statuses or for debugging, as defined by users.
		Blinking	

# Connecting Displays

The DA-920E comes with one DisplayPort with 1920 x 1200 full HD resolution at 60 Hz and one HDMI port with 1920 x 1080 full HD resolution at 60 Hz. Both display ports are located on the rear panel.

**DisplayPort is the default display interface.** Refer to the following tables for detailed information for connecting displays to the DA-920E computer.

BIOS Phase	Main Display: DisplayPort	Main Display: HDMI
Actual DP on the screen	Available	Unavailable
Actual HDMI on the screen	Unavailable	Available
Actual BMC KVM on the screen	Available	Unavailable

OS Phase	Main Display: DisplayPort	Main Display: HDMI
Actual DP on the screen	Available (main display)	Available (extended display) (AST2600 driver installed)
Actual HDMI on the screen	Available (extended display) (SM768 driver installed)	Available (main display)
Actual BMC KVM on the screen	Available DP: main display HDMI: extended display	Available HDMI: main display DP: extended display

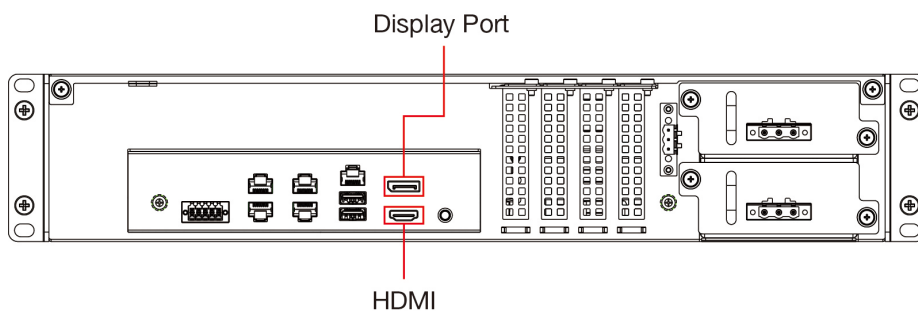

## NOTE

For optimal video streaming reliability, we recommend using premium certified HDMI cables. If you want to use a DisplayPort-to-HDMI converter, an active DisplayPort-to-HDMI adapter, such as Aten VC986, is recommended.

# Connecting USB Devices

The DA-920E comes with 2 USB 3.0 ports on the front panel and 2 USB 3.0 ports on the rear panel. The USB ports can be used to connect peripherals, such as flash drives, for expanding the system’s storage capacity.

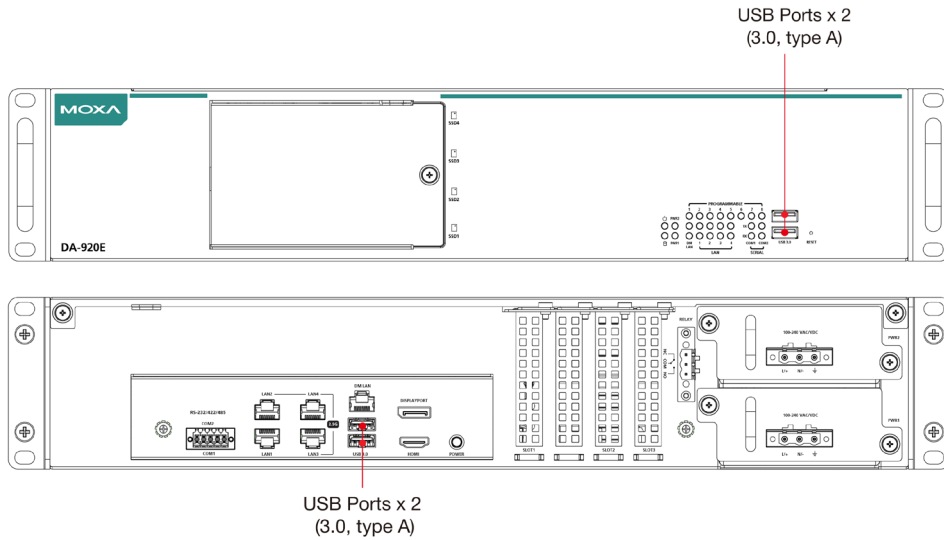

## Serial Ports

The DA-920E comes with two software-selectable RS-232/422/485 serial ports on the rear panel. The ports use terminal-block connectors. Refer to the following table for the pin assignments:

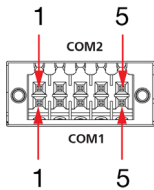

Pin	RS-232	RS-422	RS-485 (2-wire)	RS-485 (4-wire)
1	TxD	Tx+	-	Tx+
2	RxD	Tx-	-	Tx-
3	RTS	Rx+	Data+	Rx+
4	CTS	Rx-	Data-	Rx-
5	GND	GND	GND	GND

## Gigabit LAN Ports

The DA-920E is equipped with one 10/100/1000 Mbps RJ45 Ethernet port (LAN1) and three 10/100/1000/2500 Mbps RJ45 Ethernet ports (LAN2 to LAN 4), and one 10/100/1000 Mbps dedicated management LAN (DM LAN) port for out-of-band-management. The pin assignments are listed in the following table:

Refer to the following figure and table for the pin sequence and definitions.

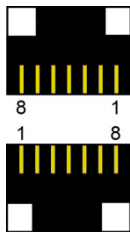

Pin	10/100 Mbps	1000/2500 Mbps
1	Tx+	TRD(0)+
2	Tx-	TRD(0)-
3	Rx+	TRD(1)+
4	-	TRD(2)+
5	-	TRD(2)-
6	Rx-	TRD(1)-
7	-	TRD(3)+
8	-	TRD(3)-

# Relay Output

The DA-920E includes a relay output located on the rear panel. The pin definitions of the relay output connectors are shown in the figure.

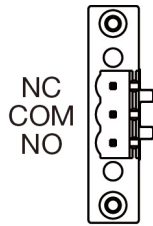

# Installing Storage Disks

The DA-920E is provided with four sockets for storage disks, enabling installation of up to four 2.5" SSDs. To access the sockets, remove the storage cover on the front panel by unfastening the screw. Pull out the SSD tray and install the SSD disk on the tray. The screws for the SSD tray are included in the product box a separate small package.

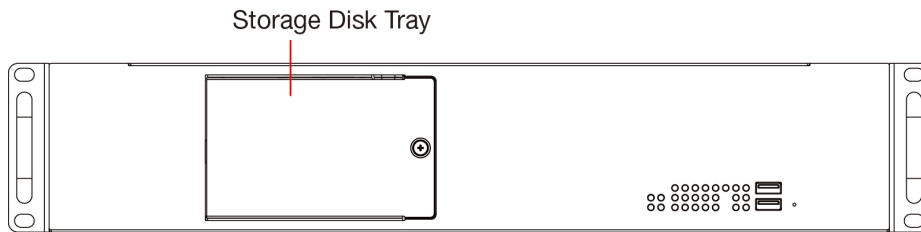

The SSD storage sequence starts from the bottom slot 1 and continues to the top slot 4.

To install the SSD storage, do the following:

1. Place the SSD storage on the installation tray and secure it with four screws on the back.



2. Open the storage disk tray door and locate the slot of the tray. Each slot has plastic rails on either sides to enable the storage tray to slide in.

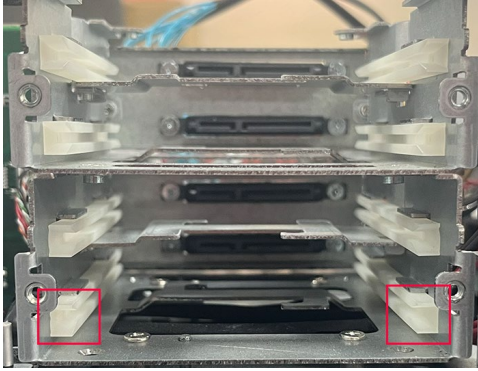

3. Insert the storage tray onto to the rail of slot 1.

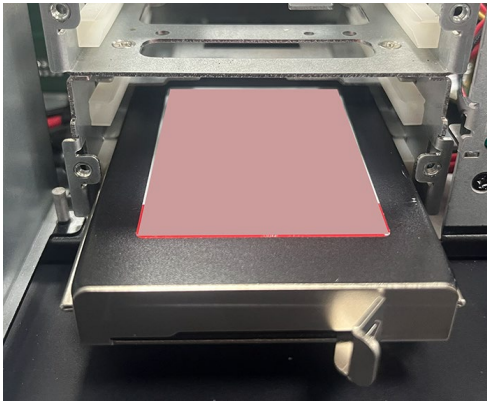

4. Push the handler to the right to secure the tray in place.

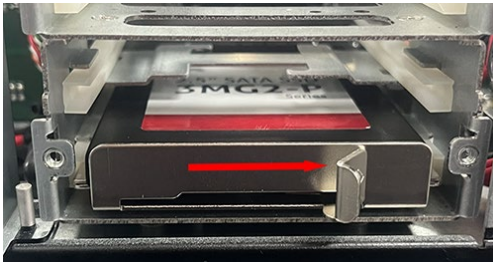

5. To remove the storage tray, push the handler to the left and pull out the tray.

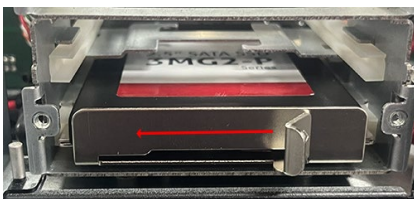

# Installing the M.2 Storage Module

The DA-920E comes with 1 M.2 M-key 2280 slot on the bottom side. To access the slot, remove the storage cover by unfastening the four screws as indicated in the following figure:

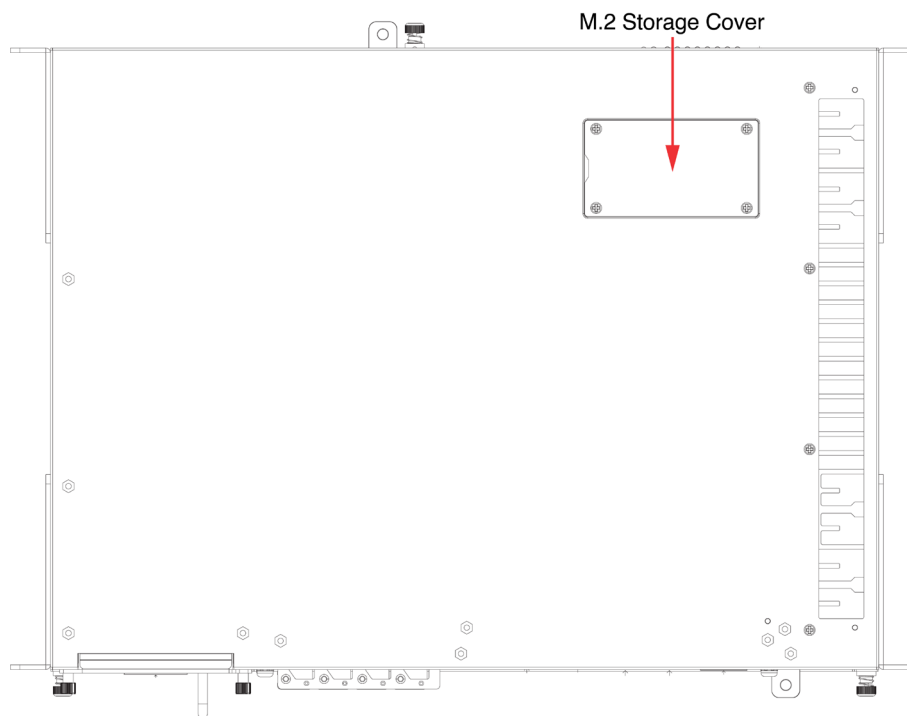

To install the M.2 storage module, do the following:

1. Insert the M.2 module into the slot.
2. Fasten the screw on the module to secure it to the slot.

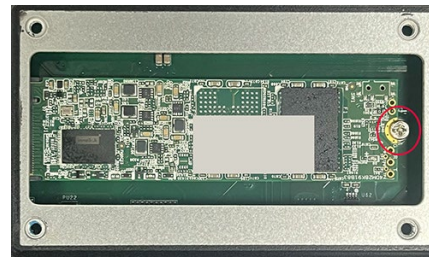

3. Paste the thermal pad on the module.



4. Reattach the cover and fasten the four screws.

# Installing the Memory Module

To access the memory slots, unfasten the two hand-rotated screws and remove the cover of the computer.

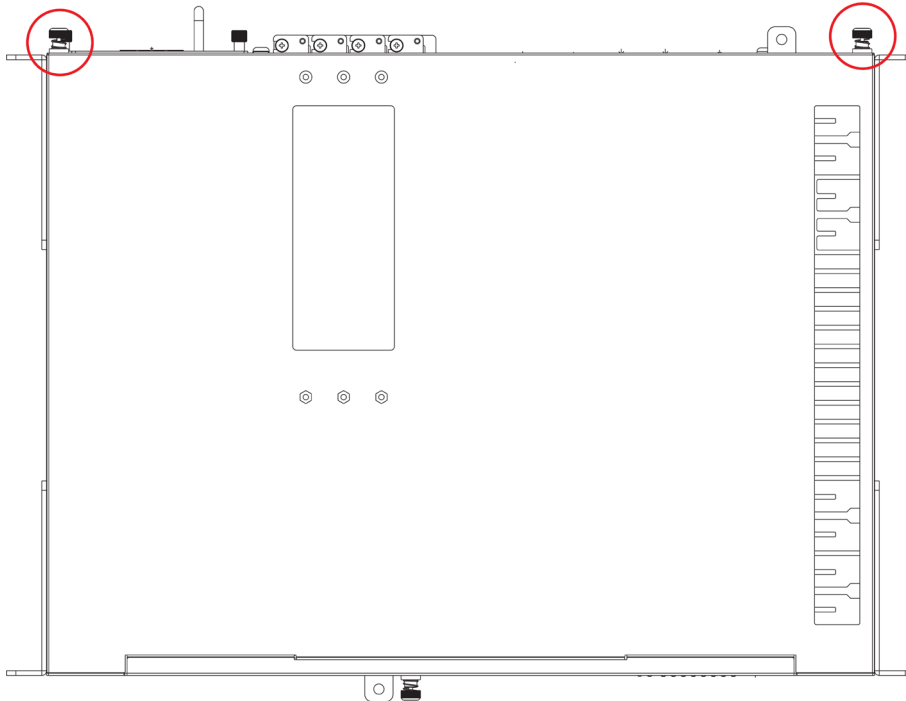

To install the memory module, do the following:

1. Remove the computer cover and locate the black heat sink. The memory slots are located under the black heat sink.
2. Unfasten the four screws on the heat sink and remove it.

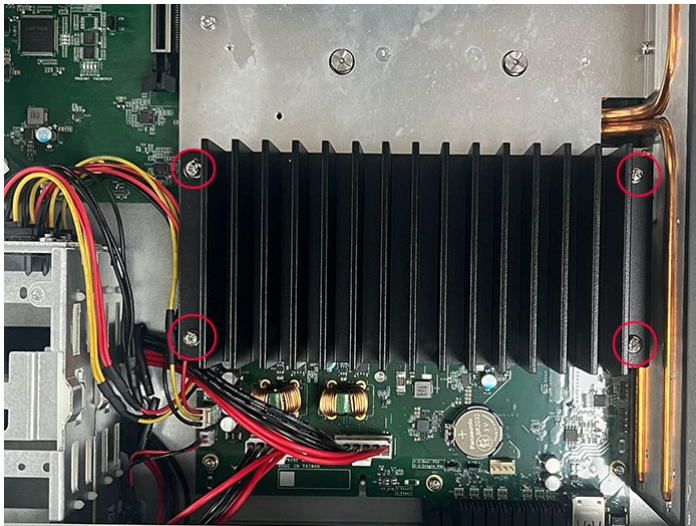

3. There are four memory slots—A1, B1, A2, and B2. Install your first memory module in the A1 slot and the second one in the B1 slot. For the second set, install the first module in the A2 slot and the last one in the B2 slot.

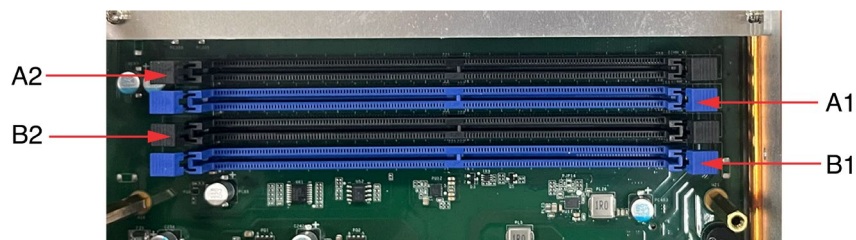

4. Insert the module in the slot and push downwards until the latches on two sides are secured.



5. Replace the heat sink and fasten the four screws.
6. Attach the outer cover of the computer and secure it.



## NOTE

The heat sink is designed to fit in a certain direction for an error-proof installation. If you have an issue installing the heat sink, adjust the direction and try again. Do not force the heat sink into the installation space.

## Installing Expansion Modules

The DA-920E is equipped with three standard PCIe slots located on the rear of the computer for installing expansion modules. The slots also support installation of low-profile standard PCIe cards, providing flexibility for extending customized interfaces. The following table lists the interfaces supported on the three slots:

Slot 1	Slot 2	Slot 3
PCIe x16	PCIe x8	PCIe x4 (2-lane)

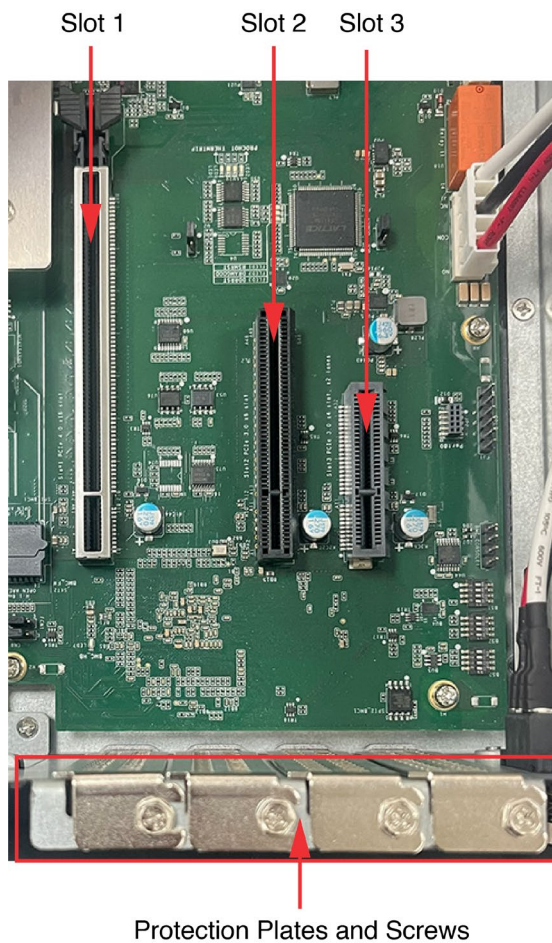



## WARNING

Power off the computer before installing the expansion modules to avoid damage to the computer.

To install a PCIe card into a slot, do the following:

- Unfasten the screw and remove the protection plate.
- Insert the PCIe card into the slot and fasten the screw to secure it.

## Hardware Security and Installing Locks

The DA-920E comes with two hardware security mechanisms located on the front panel and the rear panel as indicated in the following figure:

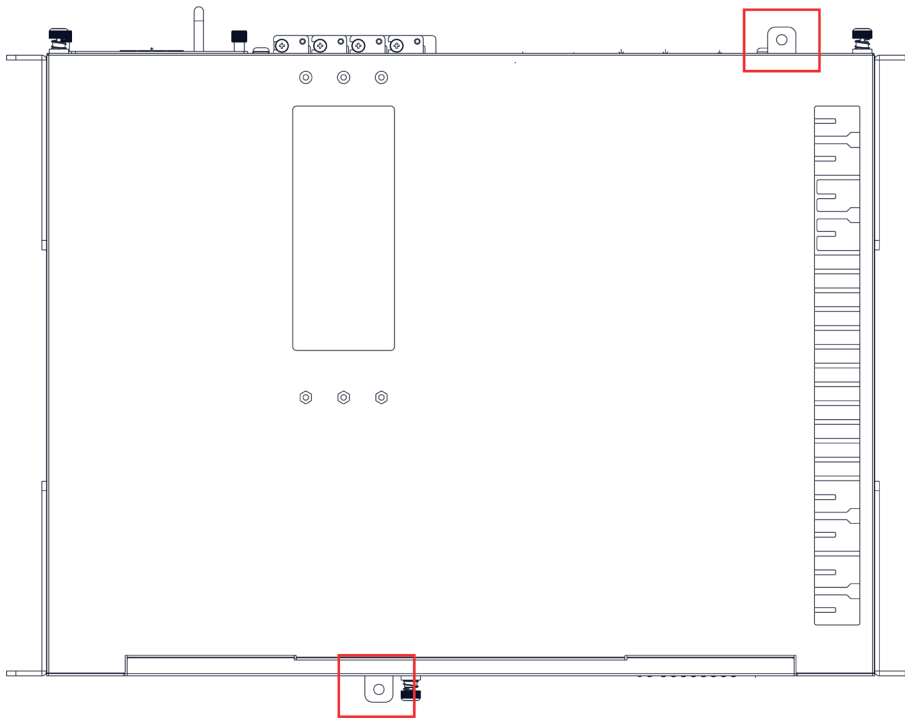

## NOTE

The diameter of the lock is 5.5 mm, we suggest you use the locks with the diameter less than 4 mm.

The one in the front is designed to protect the storage tray from being replaced or stolen, while the rear one is to protect the cover from being opened. Install locks on the apertures to protect the computer from being tampered.

# Ventilation

The DA-920E comes with three vents located on the top as shown in the following figure. By default, each vent is covered up with a plate secured by two screws, installed against the inner side of the computer cover.

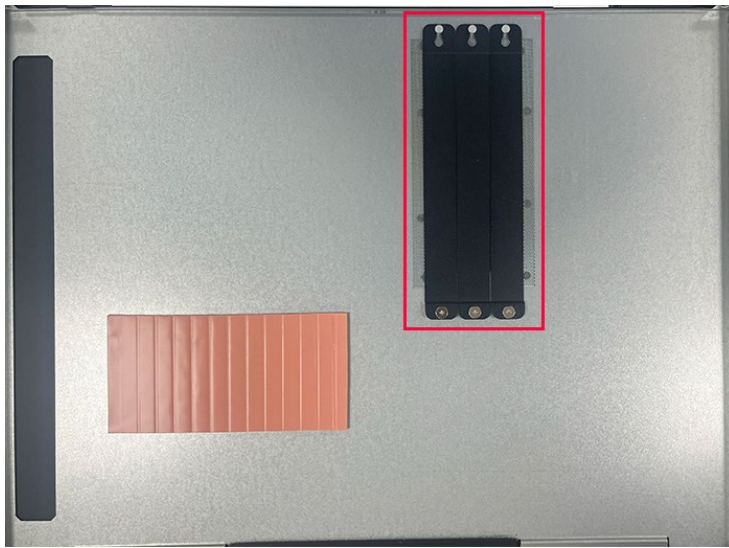

To clear a vent, remove the plate covering it by unfastening the two screws.

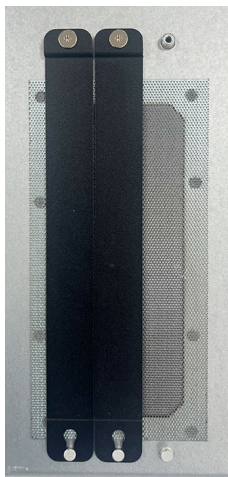

# RTC Battery



## WARNING

There is a risk of explosion if the wrong type of battery is used. To avoid this potential danger, always be sure to use the correct type of battery. We suggest you use **Panasonic BR2032** battery. Contact the Moxa RMA service team if you need to replace your battery. Dispose of used batteries according to the instructions on the batteries.

To replace the RTC battery, do the following:

1. Use a screwdriver to push the right latch of the battery slot outwards.

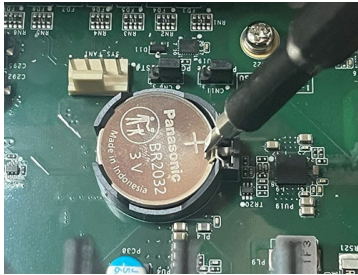

2. Remove the old battery and insert the new one.

## 3. BIOS Setup

In this chapter, we describe the BIOS settings for the DA-920E computer. The BIOS is a set of input/output control routines for peripherals to initialize the basic settings. The BIOS helps boot the system before the operating system is loaded. The BIOS setup allows the user to modify the system configuration for basic input/output peripherals.

### Entering the BIOS Setup

To enter the BIOS setup utility, press the F2 key while the system is booting up. The main BIOS Setup screen will appear. You can configure the following settings on this screen.

- **Continue:** Continue to boot up
- **Boot Manager:** Select the device for boot up
- **Device Management:** Enter the device configuration menu
- **Boot From File:** Select the UEFI boot up file
- **Administer Secure Boot:** Enter the Secure Boot menu
- **Setup Utility:** Enter the BIOS configuration menu

Select **F2** to enter the **BIOS configuration**.

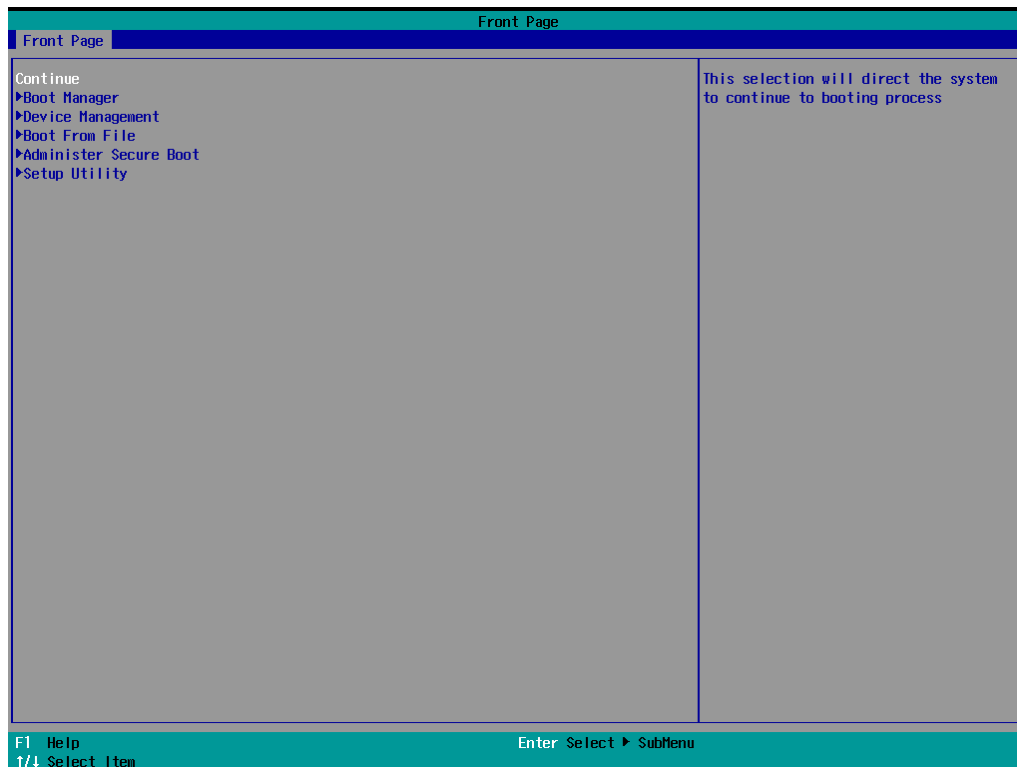

When you enter the **Setup Utility**, a basic description of each function key is listed at the bottom of the screen. Refer to these descriptions to learn how to use them.

<b>F1</b>	<b>General Help</b>	↑ ↓	<b>Select Item</b>
<b>F5/F6</b>	<b>Change Values</b>	← →	<b>Select Menu</b>
<b>F9</b>	<b>Setup Defaults</b>	<b>ESC</b>	<b>Exit</b>
<b>F10</b>	<b>Save and Exit</b>	<b>ENTER</b>	<b>Select or go to Submenu.</b>

The BIOS configuration screen will be shown when you enter the **Setup Utility** option.

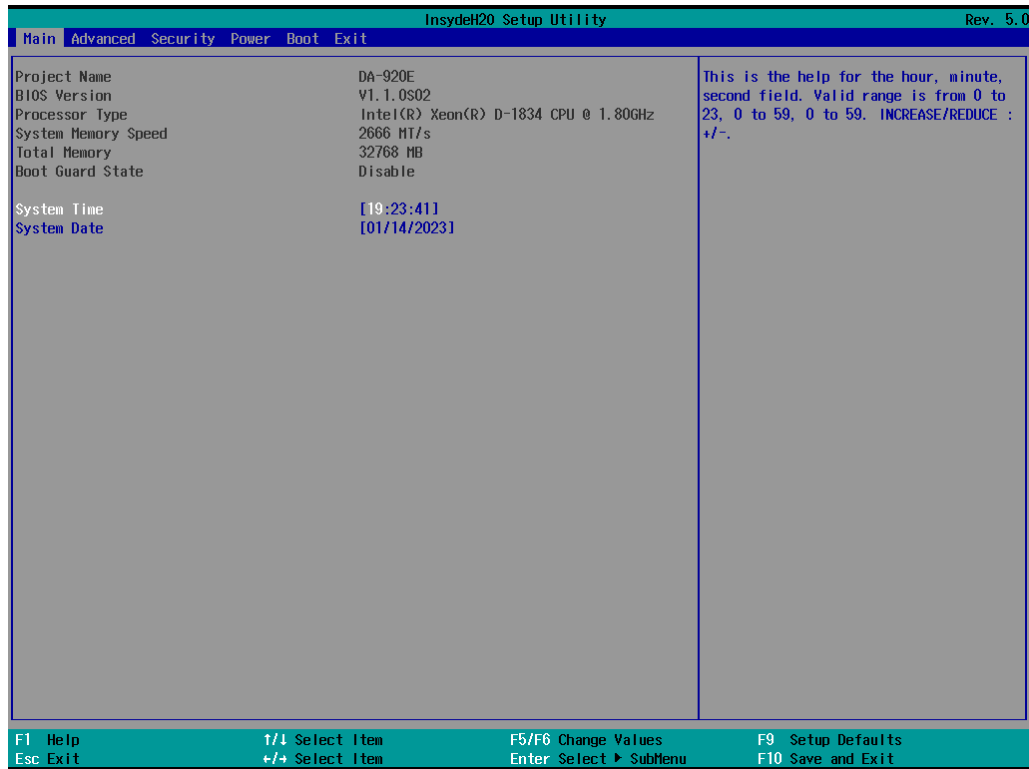

# Main Page

The **Main** page displays basic hardware information, such as model name, BIOS version, and CPU type.

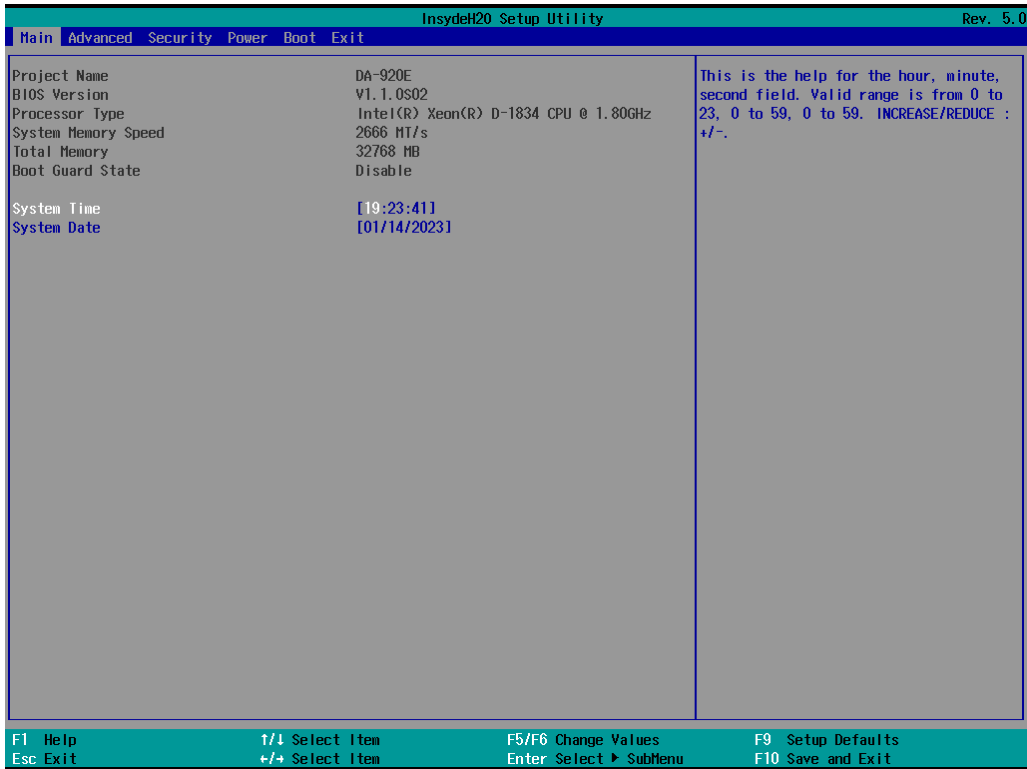

# Advanced Settings

Select the **Advanced** tab in the main menu to open the advanced features screen.

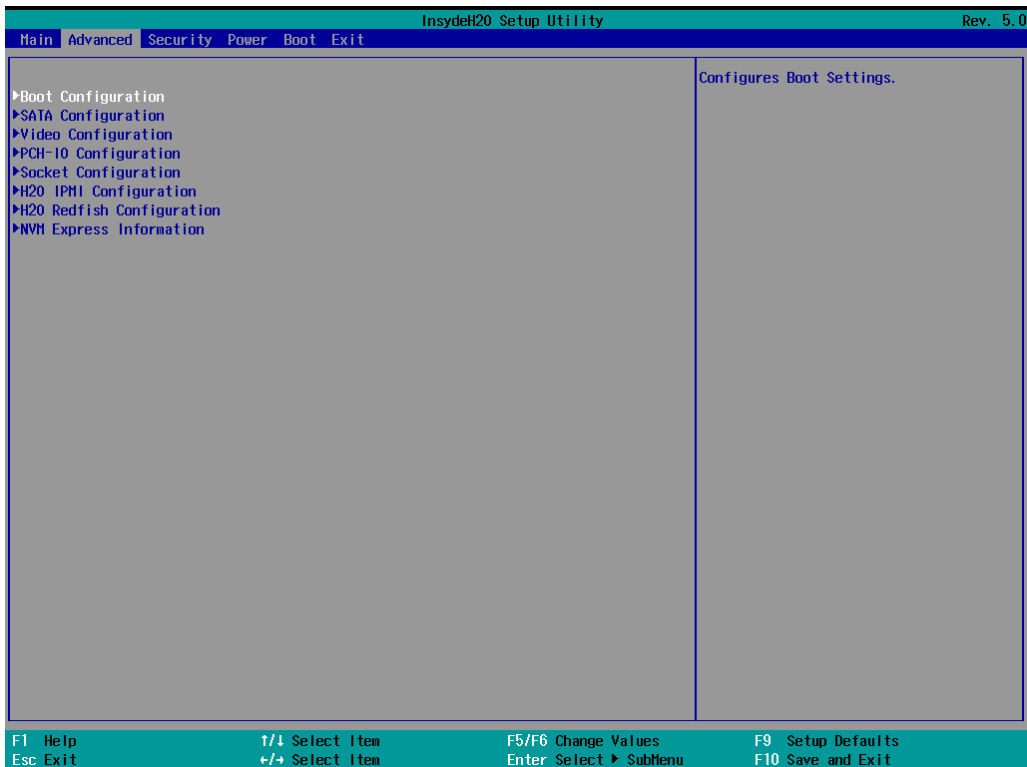

# Boot Configuration

The **Numlock** option allows configuration of the Numlock value

Options: On (default), Off.

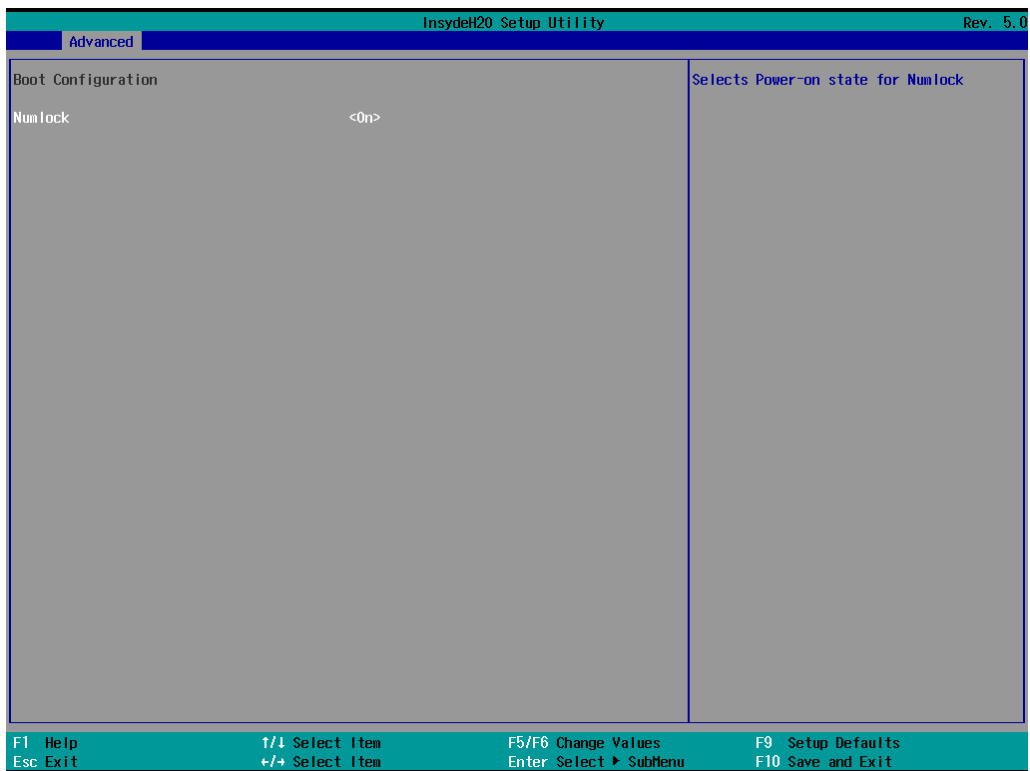

# SATA Configuration

This section allows you to select the SATA speed limit and hot plug setting.

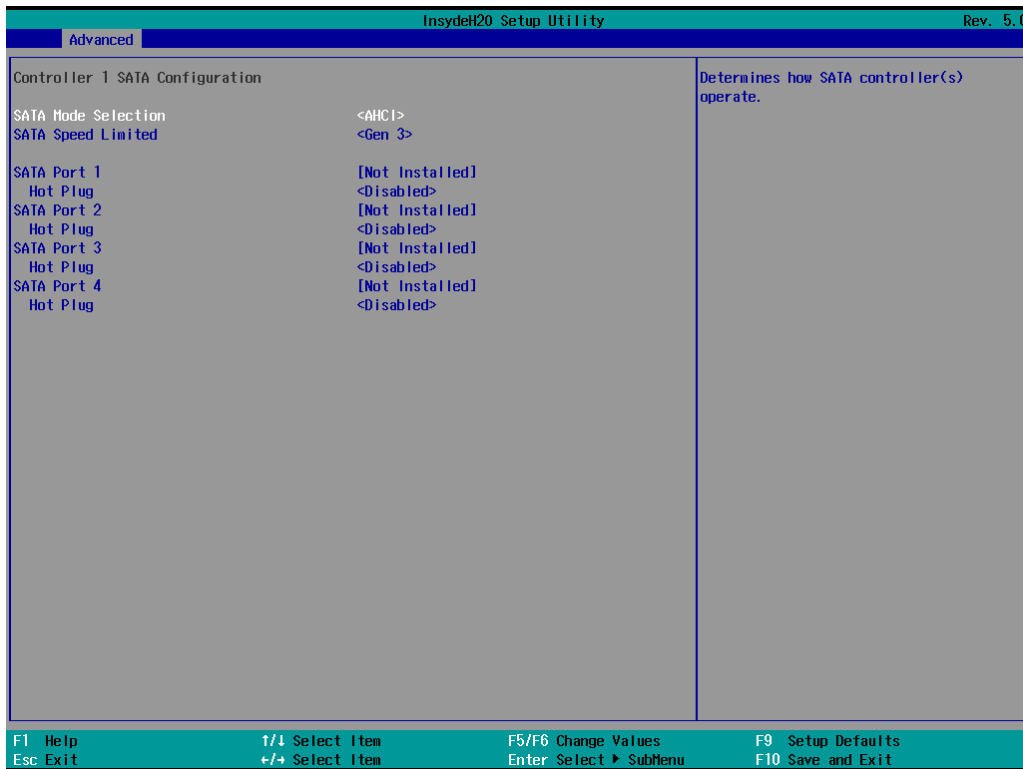

## SATA Mode Selection

Options: AHCI (default), RAID

## SATA Speed Limited

Options: Auto (default), Gen 1, Gen 2, Gen 3

## Serial ATA Port

This setting displays information on the installed drives.

## ATA Port Hot Plug

This setting allows you to enable/disable hot-plugging capabilities (the ability to remove the drive while the computer is running) that are configured by software for installed storage drives.

Options: Disabled (default), Enabled

## RAID

You must enable the **Map SATA Root Port** under **VMD** for the redundant array of inexpensive disks technology. The device has two SATA interfaces that only support RAID level 0 and RAID level 1.

When using the continuous update policy, changes made to the data on the master drive while the system is not docked are automatically copied to the recovery drive when the system is re-docked. When using the on-request update policy, the master drive data can be restored to a previous state by copying the data on the recovery drive back to the master drive.

Source: [http://en.wikipedia.org/wiki/Standard\\_RAID\\_levels](http://en.wikipedia.org/wiki/Standard_RAID_levels) for details.

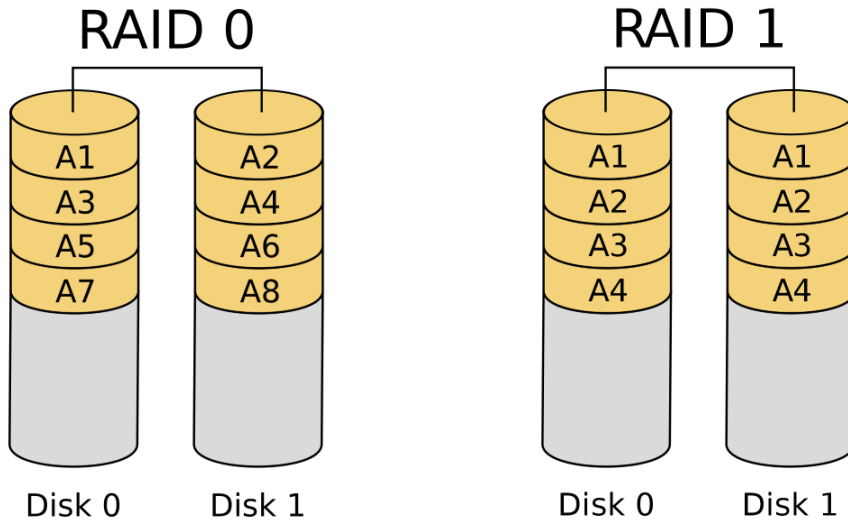

## Intel Rapid Storage Technology

This section allows users to configure Intel® Rapid Storage Technology.

After saving changes, and rebooting the system, you can select the Device Manager to configure the Intel Rapid Storage Technology settings.



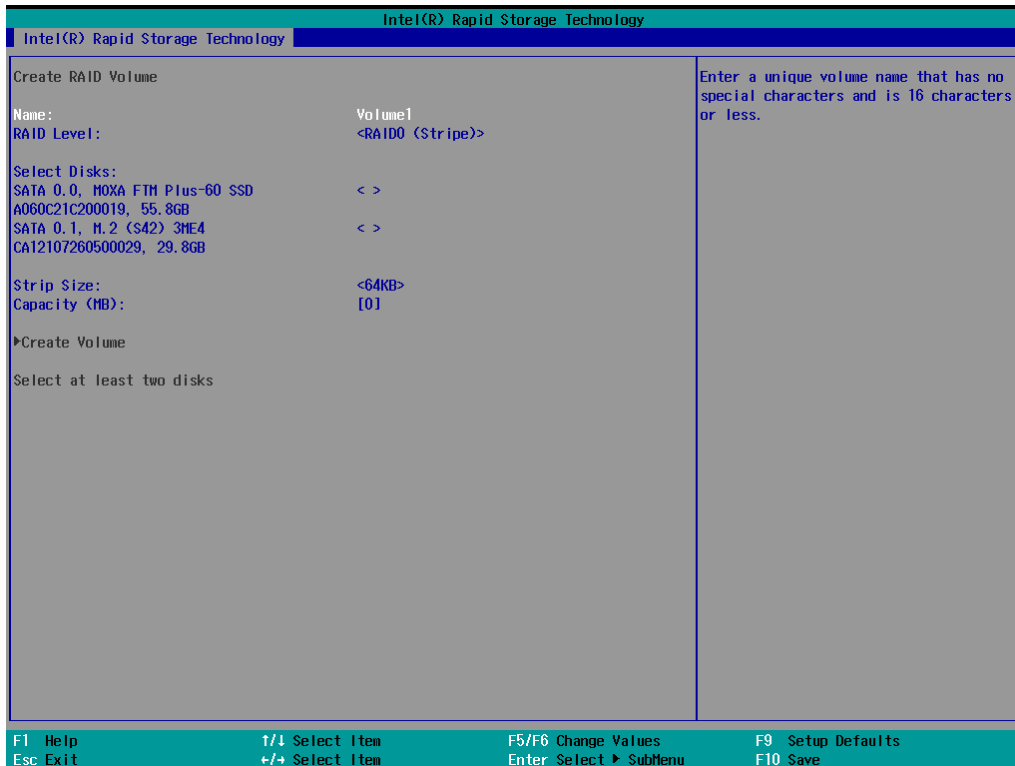

## CPU Configuration



### Display Mode

Set display mode configuration type.

Options: Main Display – DP (default), Main Display – HDMI

# PCH-IO Configuration

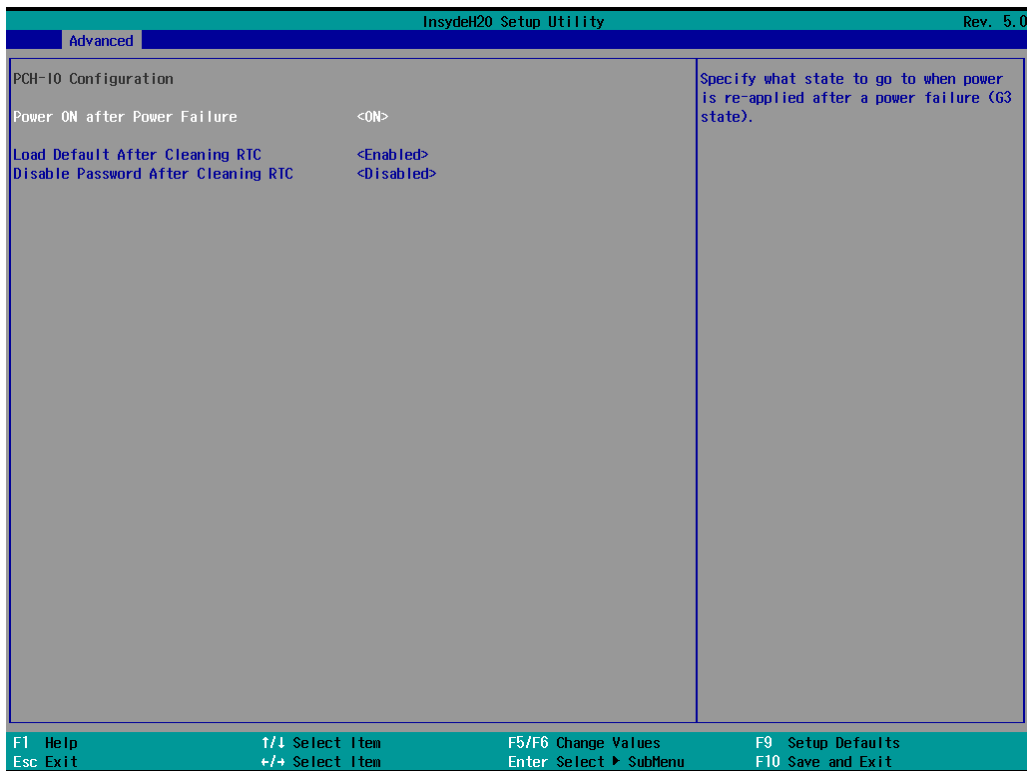

## Power ON after Power Failure

This item allows you to enable/disable the computer from automatically powering up after system power is re-enabled.

Options: ON (default), OFF, Last State

## Load Default After Cleaning RTC Battery

System will load default when detecting RTC battery loss.

Options: Disabled, Enabled (default)

## Disable Password After Cleaning RTC

This item determines whether the BIOS password should be cleared automatically when the RTC battery is removed or the RTC record is cleared.

Options: Disable(default), Enabled

# Socket Configuration

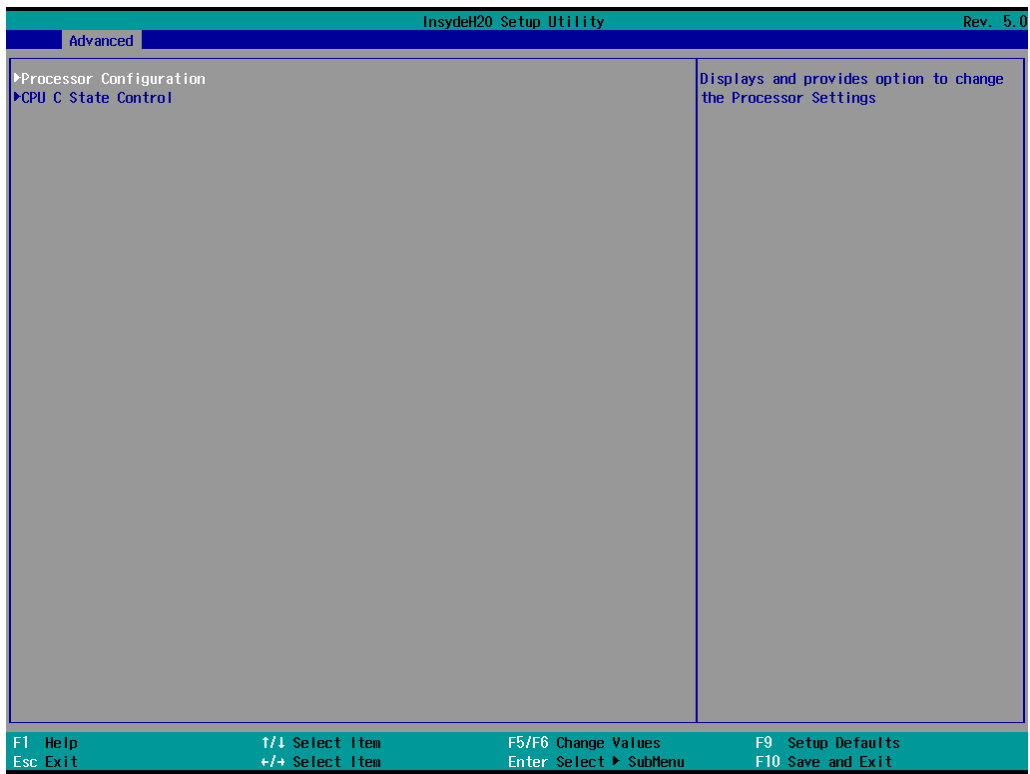

# Processor Configuration

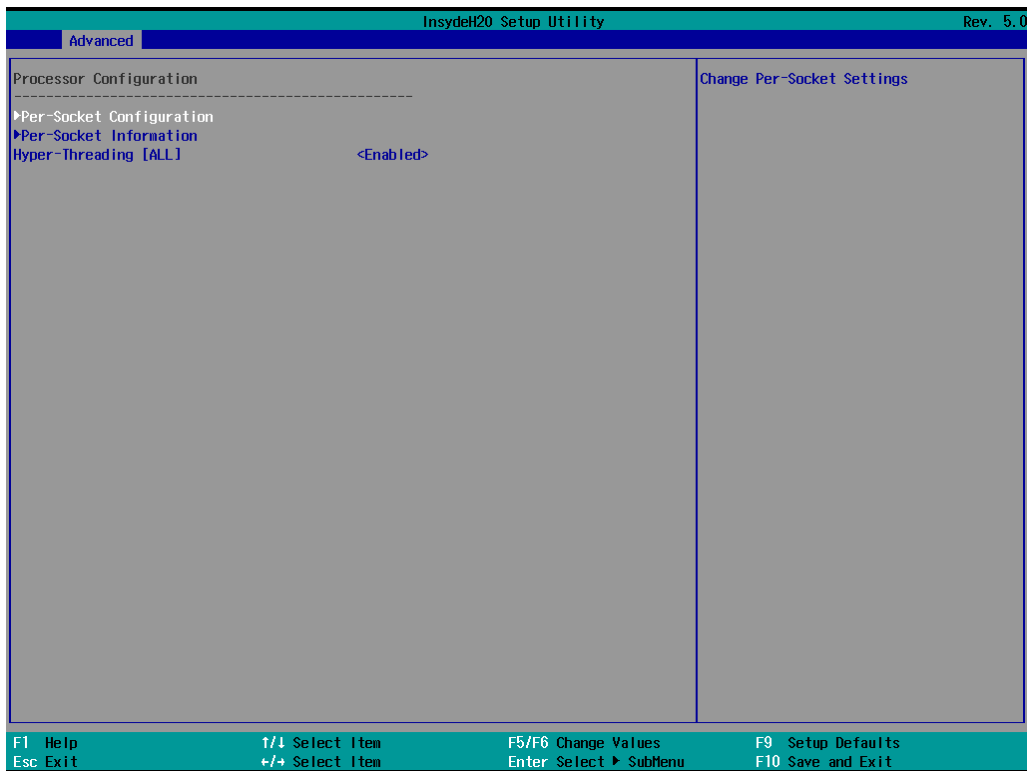

## Per-Socket Configuration

This item allows you to enter the sub-menu to configure the active core count or specific core settings for each individual processor socket.

## Per-Socket Information

This item allows you to enter the sub-menu to view detailed hardware specifications and status for each processor socket, such as CPU ID, microcode version, and cache size.

## Hyper-Threading [ALL]

This feature makes the processor resources work more efficiently, enabling multiple threads to run on each core. It also increases processor throughput, improving overall performance on threaded software.

Options: Disabled, Enabled (default)

# CPU C State Control

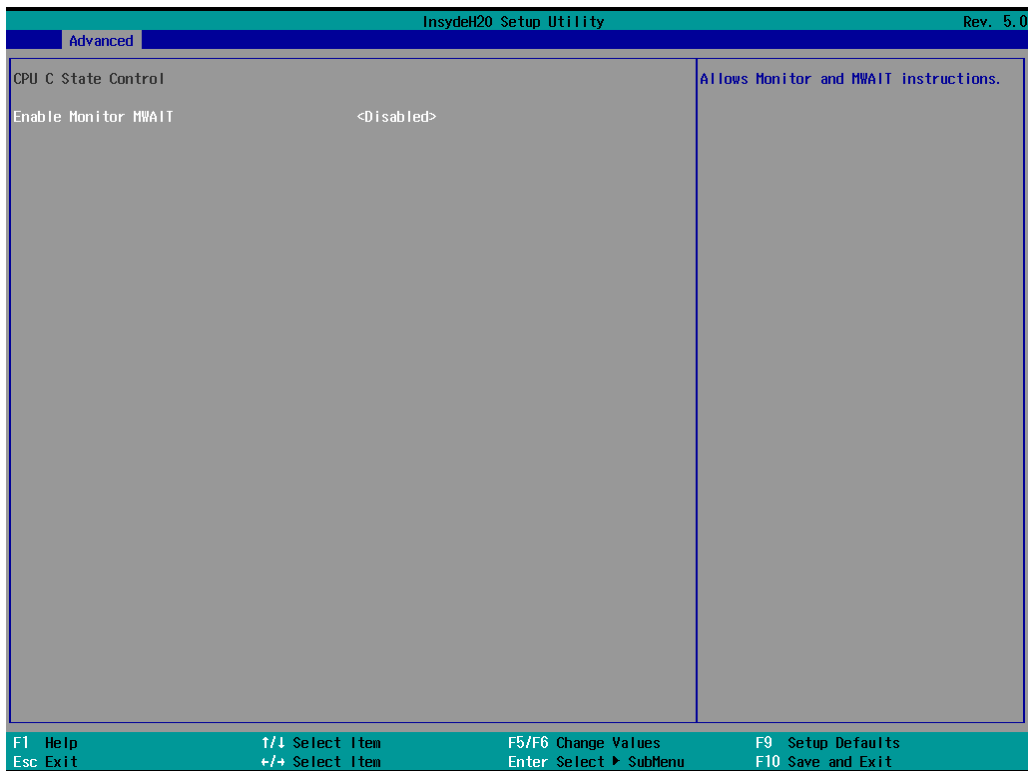

## Enable Monitor MWAIT

Enable/Disable CPU Power Management. Allows CPU to go into C status when it's not 100% utilized.

Options: Disabled (default), Enabled

# H2O IPMI Configuration

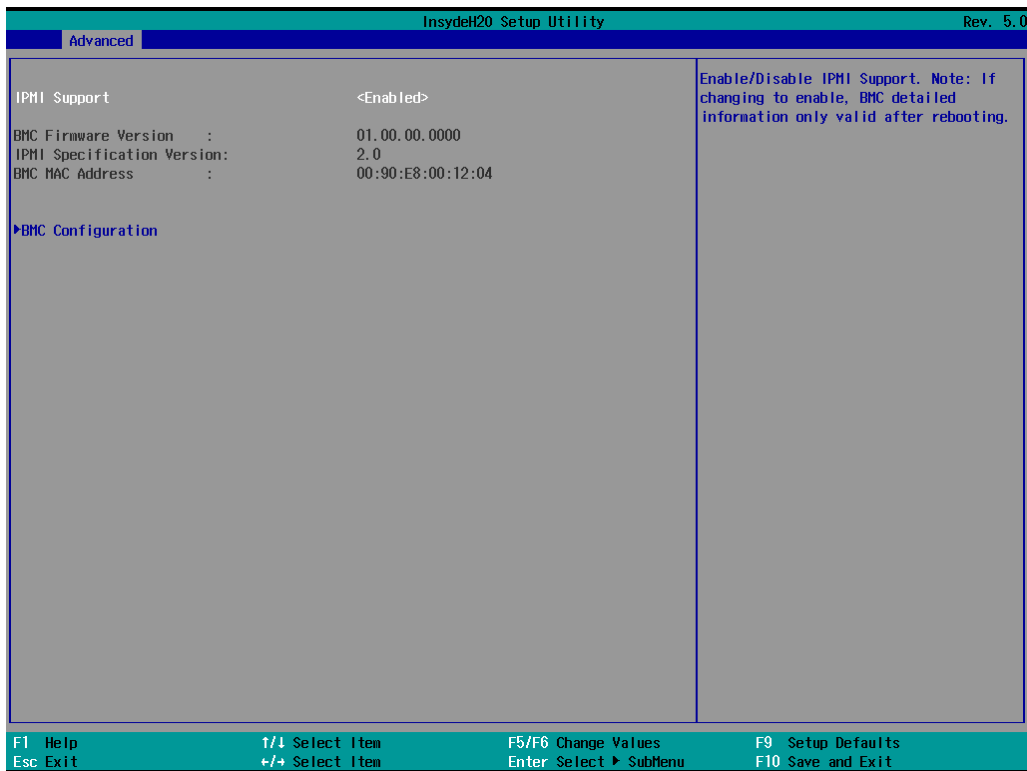

## IPMI Support

This item allows you to enable or disable the Intelligent Platform Management Interface (IPMI) support. When enabled, the system allows the Baseboard Management Controller (BMC) to monitor system health and manage the server remotely.

Options: Enabled (default), Disabled

## BMC Configuration

This item allows you to enter the sub-menu to configure detailed BMC settings, such as network configuration (IP address, Gateway, Subnet mask) and other management-related parameters.

# H2O Redfish Configuration

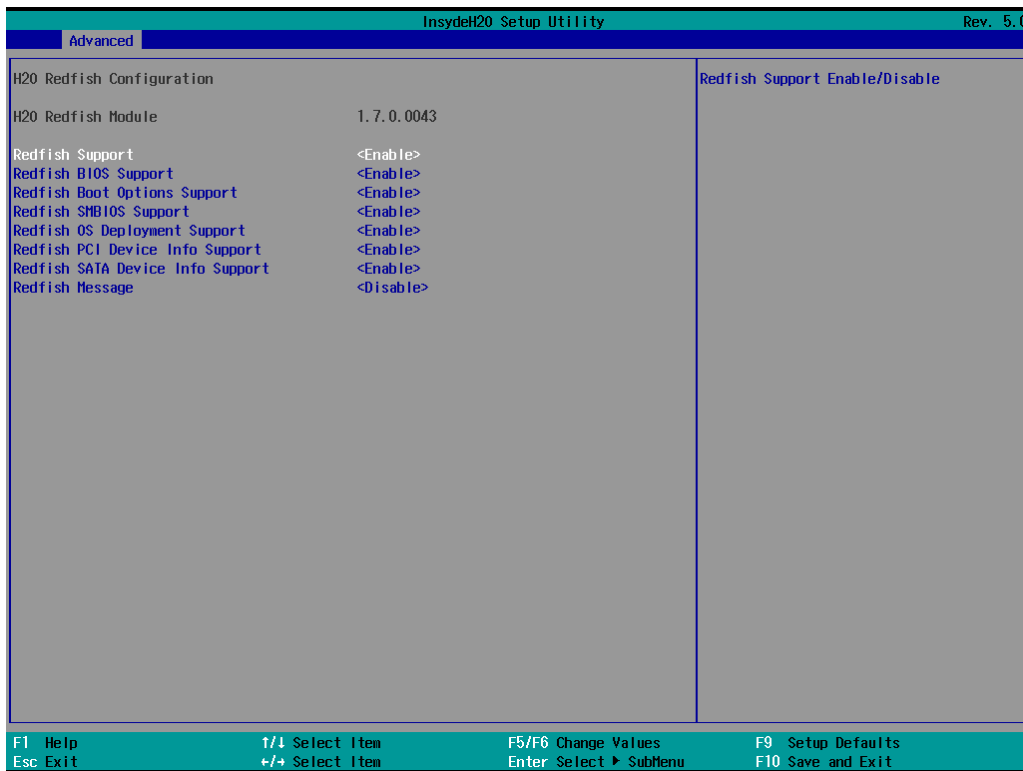

## Redfish Support

This item allows you to enable or disable the overall Redfish service. Redfish is a standard API that provides modern, secure, and scalable management for converged, hybrid IT and the Software Defined Data Center (SDDC). Options: Enable (default), Disable

## Redfish BIOS Support

This item allows you to enable or disable Redfish access to BIOS inventory and settings. When enabled, BIOS attributes can be viewed or configured remotely via the Redfish interface.

Options: Enable (default), Disable

## Redfish Boot Options Support

This item allows you to enable or disable the management of system boot options through Redfish. This includes viewing the boot order and setting a one-time boot override.

Options: Enable (default), Disable

## Redfish SMBIOS Support

This item allows you to enable or disable the reporting of SMBIOS (System Management BIOS) data through the Redfish service, providing detailed hardware inventory information to management software.

Options: Enable (default), Disable

## Redfish OS Deployment Support

This item allows you to enable or disable support for remote OS deployment via Redfish. This is typically used for automated provisioning of the operating system.

Options: Enable (default), Disable

## Redfish PCI Device Info Support

This item allows you to enable or disable the collection and reporting of PCI/PCIe device information through Redfish.

Options: Enable (default), Disable

## Redfish SATA Device Info Support

This item allows you to enable or disable the collection and reporting of SATA storage device information through Redfish.

Options: Enable (default), Disable

## Redfish Message

This item allows you to enable or disable Redfish event logging and messaging. When enabled, the system will generate Redfish-compliant messages for system events.

Options: Disable (default), Enable

## NVM Express Information

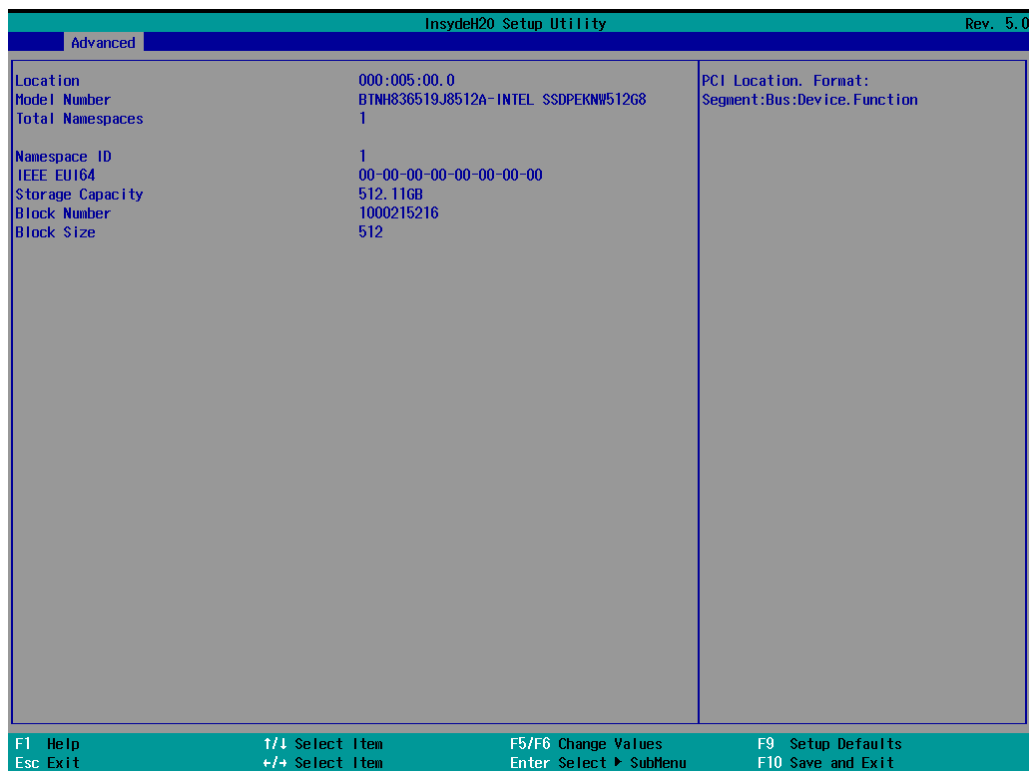

These items display the hardware specifications and logical configuration of the NVMe storage device currently connected to the system.

# Security Settings

This section allows users to configure security-related settings with a supervisor password.

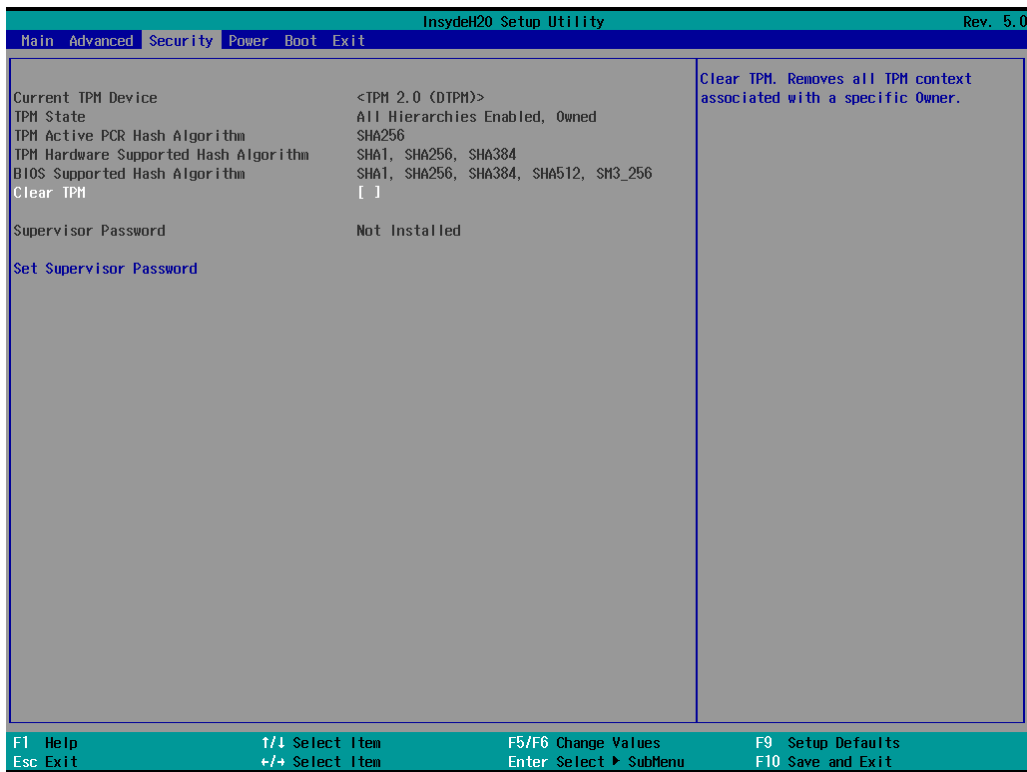

## Current TPM Device

This item shows if the system has TPM device and its type.

## TPM State

This item allows you view the status of current TPM settings.

## Clear TPM

This item allows users to remove all TPM context associated with a specific owner.

# Set Supervisor Password

This item allows you to set the supervisor password. Select the **Set Supervisor Password** option and enter the password and confirm the password again.

To delete the password, select the **Set Supervisor Password** option and enter the old password; leave the new password fields blank, and then press enter.

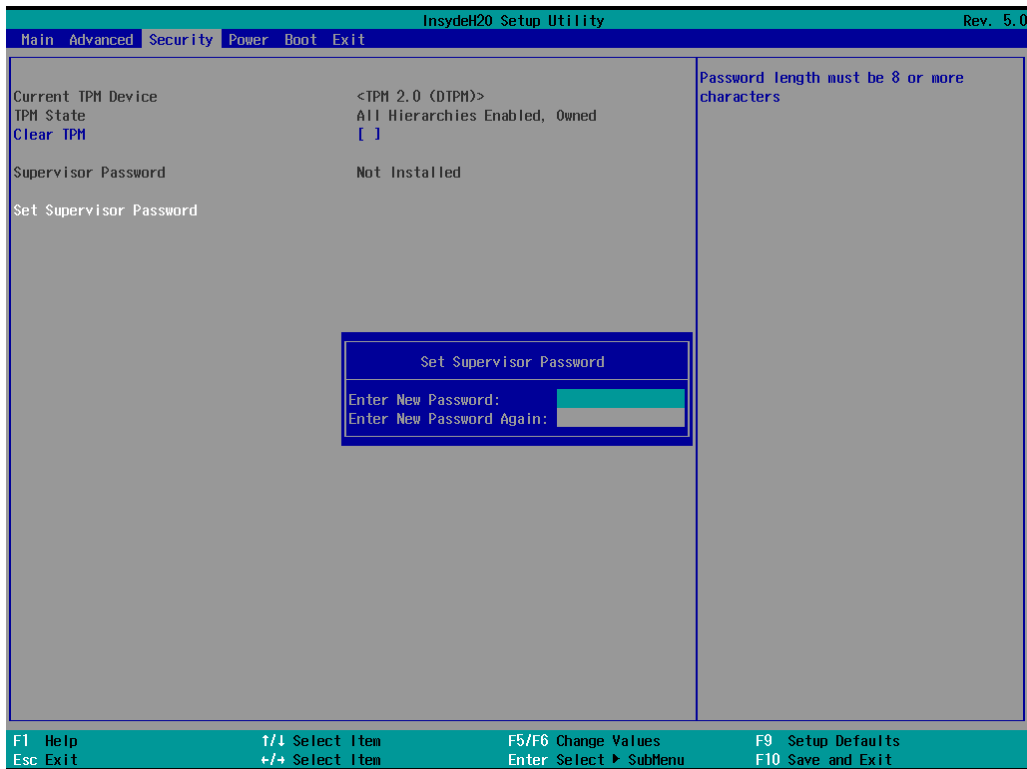

After setting the supervisor password, users can choose when the input password screen should be displayed.

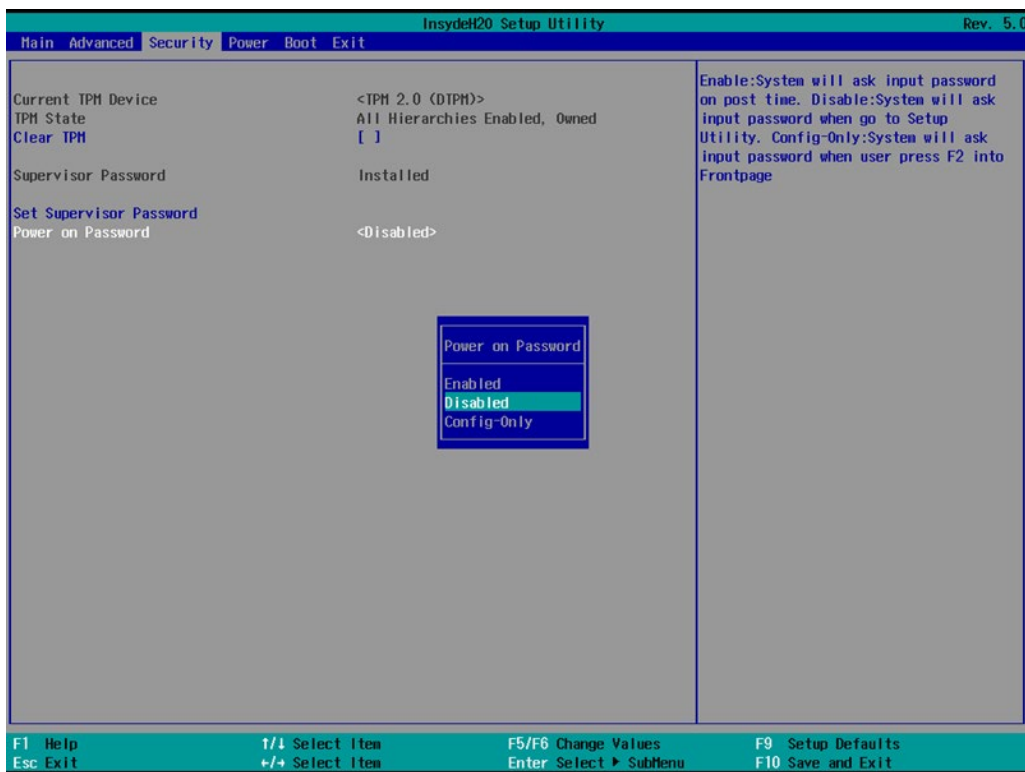

Enable: System will ask for the password on post time

Disable: System will ask for the password to go to the setup utility

Config-Only: System will only ask for the password when you select the config (F2) option

# Power Settings

This section allows users to configure power settings.

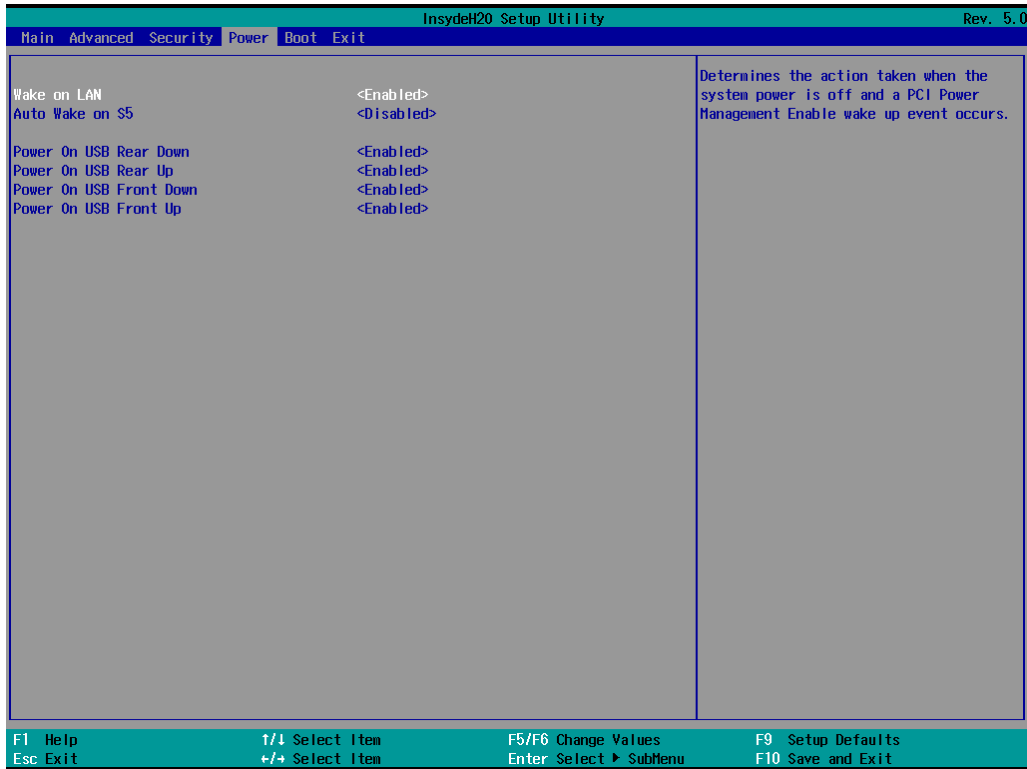

## Wake on LAN

This feature is used to wake the system by a LAN device from a remote host.

Options: Enabled (default), Disabled

## Auto Wake on S5

This item allows you to configure the computer to wake from S5 status. S5 stands for Soft Off, where the PSU remains engaged but power to all other parts of the system is cut. Auto-wake on S5 schedules a soft-reboot at certain periodic times that may be specified in the BIOS.

Options: Disabled (default); By Every Day (user specifies a regular daily time when the computer will power up); By Day of Month (user specifies a regular day each month when the computer will power up)

## Power On USB (Rear Down)

This item allows users to power on or power off the USB ports on the rear down panel.

Options: Disabled, Enabled (default)

## Power On USB (Rear Up)

This item allows users to power on or power off the USB ports on the rear up panel.

Options: Disabled, Enabled (default)

## Power On USB (Front Down)

This item allows users to power on or power off the USB ports on the front down panel.

Options: Disabled, Enabled (default)

## Power On USB (Front Up)

This item allows users to power on or power off the USB port on the front up panel. .

Options: Disabled, Enabled (default)

# Boot Settings

This section allows users to configure boot settings.

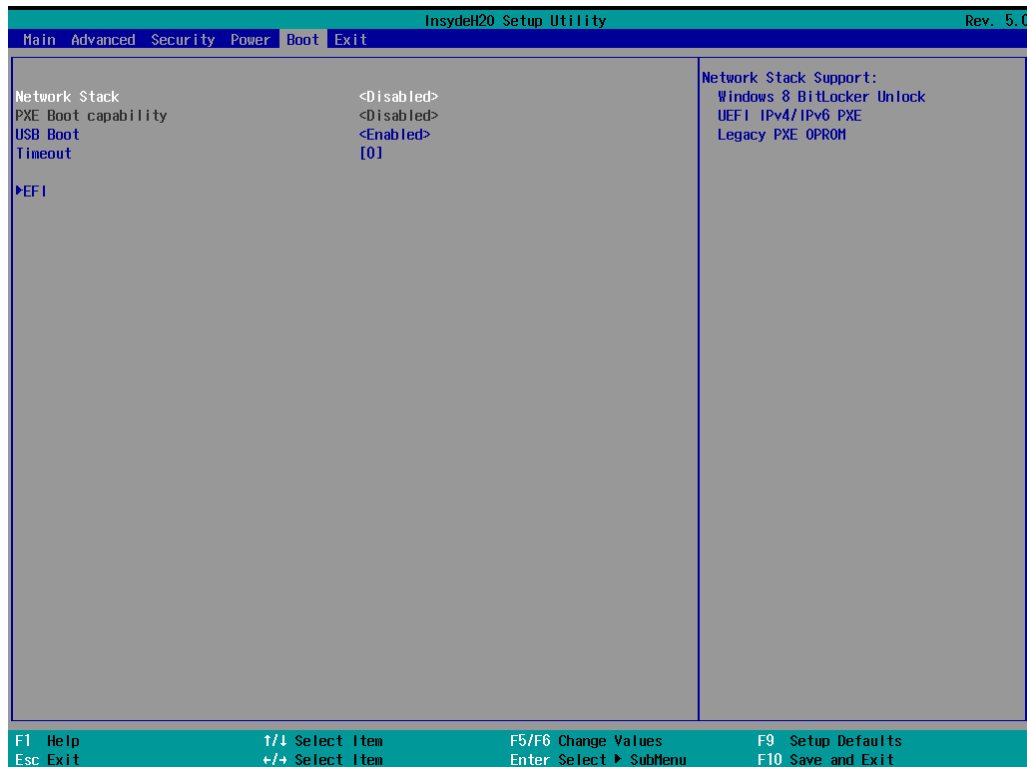

## NOTE

If you do not add any storage, you will not see the EFI option.

## Network Stack

It deploys an Internet Protocol (IP) stack. The IP stack provides an application library to open/close connections to remote devices and send/receive data between the remote devices.

Options: Disabled (default), Enabled

## PXE Boot capability

This item will be shown only when you have enabled the Network Stack.

PXE Booting is booting a system over a network. This item allows users to start PXE over IPv4 or IPv6

Options: Disabled (default), UEFI: IPv4, UEFI: IPv6, UEFI: IPv4/IPv6

## USB Boot

Set booting to USB boot devices capability.

Options: Enabled (Default), Disabled

## Timeout

This item allows users to set the number of seconds that the firmware will wait before booting from the default boot selection.

## EFI

This item allows users to select the boot order. Use F5 (move down) or F6 (move up) to change the boot order.

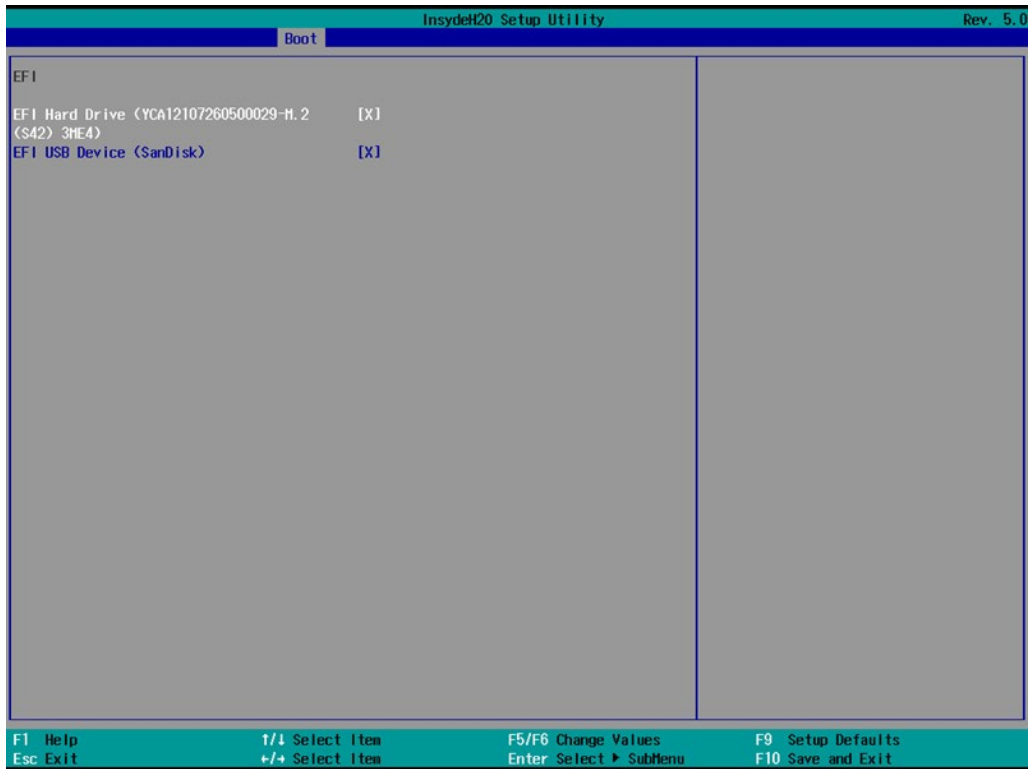

# Exit Settings

The section allows users to exit the BIOS environment.

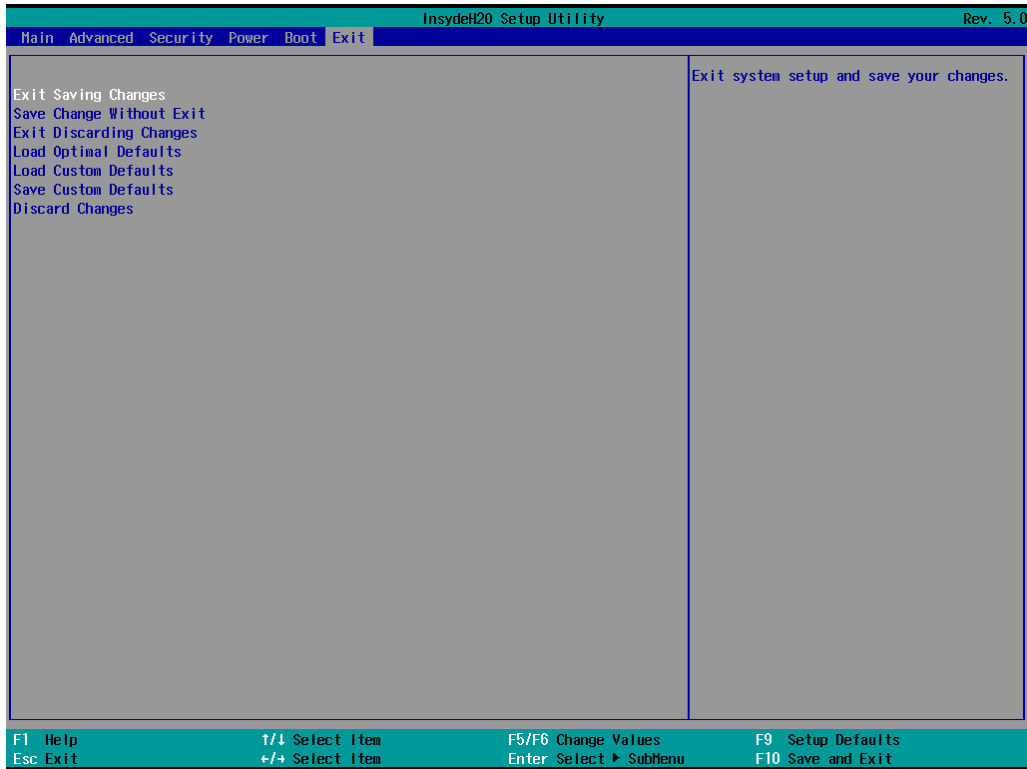

## Exit Saving Changes

This item allows you to exit the BIOS environment and save the values you have just configured.

Options: Yes (default), No

## Save Change Without Exit

This item allows you to save changes without exiting the BIOS environment.

Options: Yes (default), No

## Exit Discarding Changes

This item allows you to exit without saving any changes that might have been made to the BIOS.

Options: Yes (default), No

## Load Optimal Defaults

This item allows you to revert to the factory default BIOS values.

Options: Yes (default), No

## Load Custom Defaults

This item allows you to load custom default values for the BIOS settings.

Options: Yes (default), No

## Save Custom Defaults

This item allows you to save the current BIOS values as a “custom default” that may be reverted to at any time by the load custom defaults selection.

Options: Yes (default), No

## Discard Changes

This item allows you to discard all settings you have just configured.

Options: Yes (default), No

# Administering Secure Boot

Press F2 to go to the Administer Secure Boot.

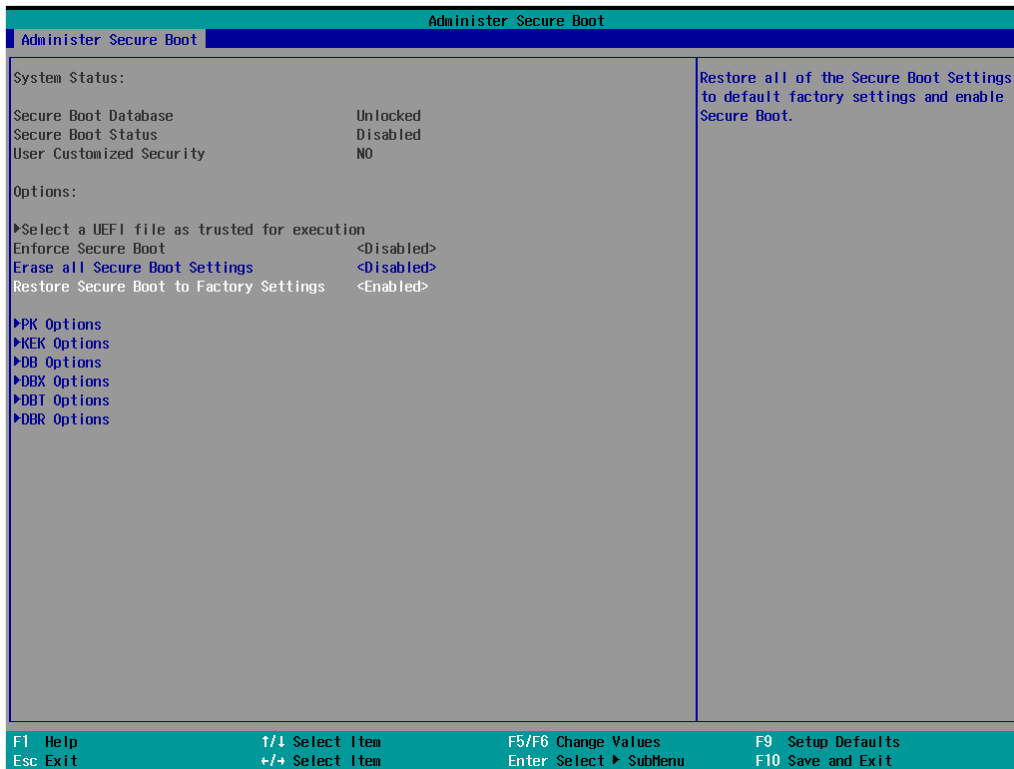

Secure Boot helps computers resist attacks and infection from malware. The feature defines an interface between the operating system and BIOS. It detects tampering with boot loaders, key operation system files, and unauthorized option ROMs by validating their digital signatures.

## Enabling UEFI Secure Boot

Set as "enabled" in "Restore Secure Boot to Factory Settings" under Administer Secure Boot menu. Press F10 as save and exist.



Moxa has included the Microsoft key in the BIOS by default. If you cannot boot up the computer using a non-Windows OS, use the following examples.

# Enroll EFI Image

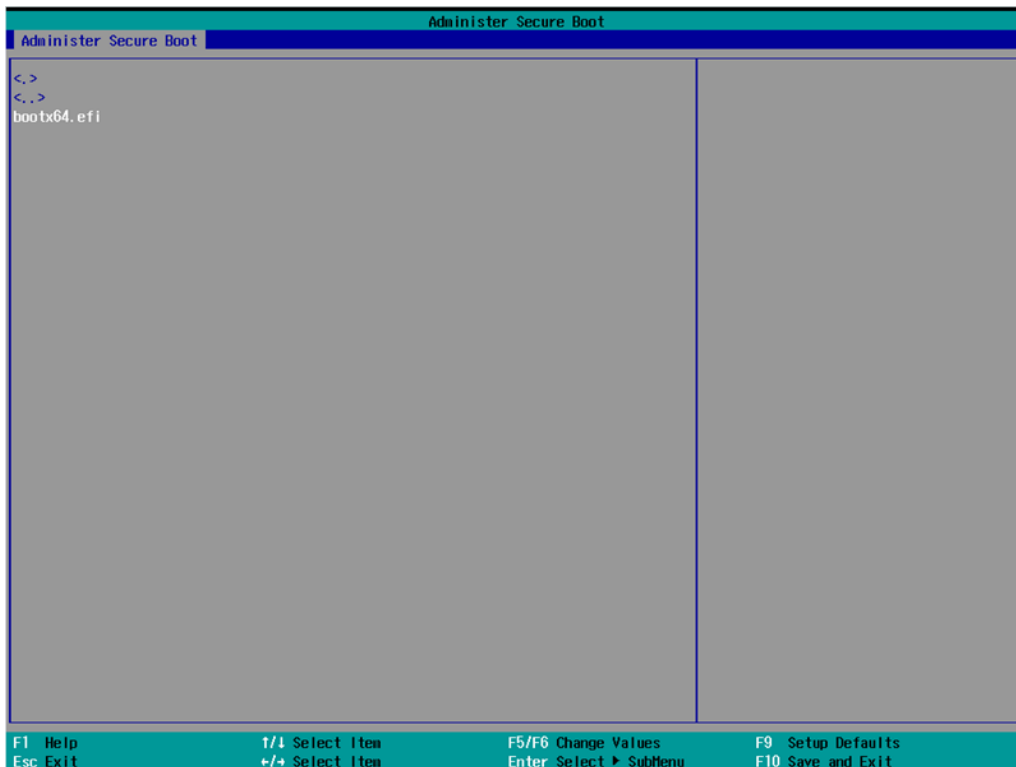
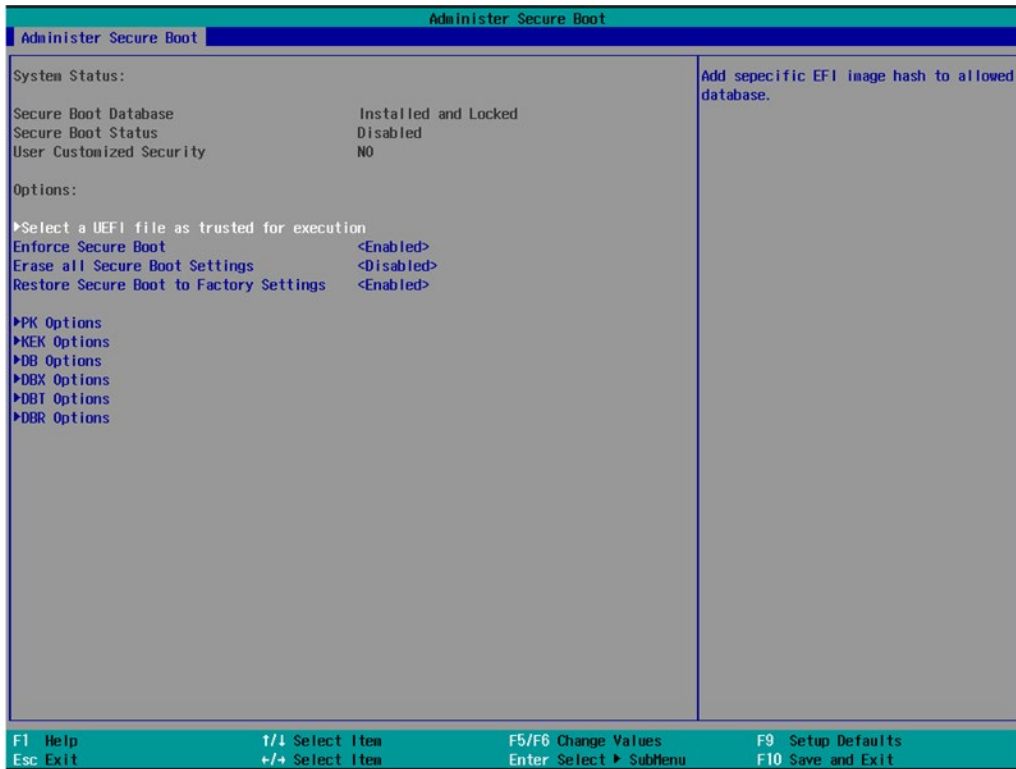

1. Enter **Administer Secure Boot** and select the option **Select a UEFI file as trusted for execution**.
2. Enter the loader name followed by the UEFI standard \EFI\BOOT\BOOT{machine type short-name}. E.g., efi\boot\BootX64.efi, Debian (EFI\debian\grubx64.efi), Suse (EFI\opensuse\grubx64.efi)

# Enroll Customer Key

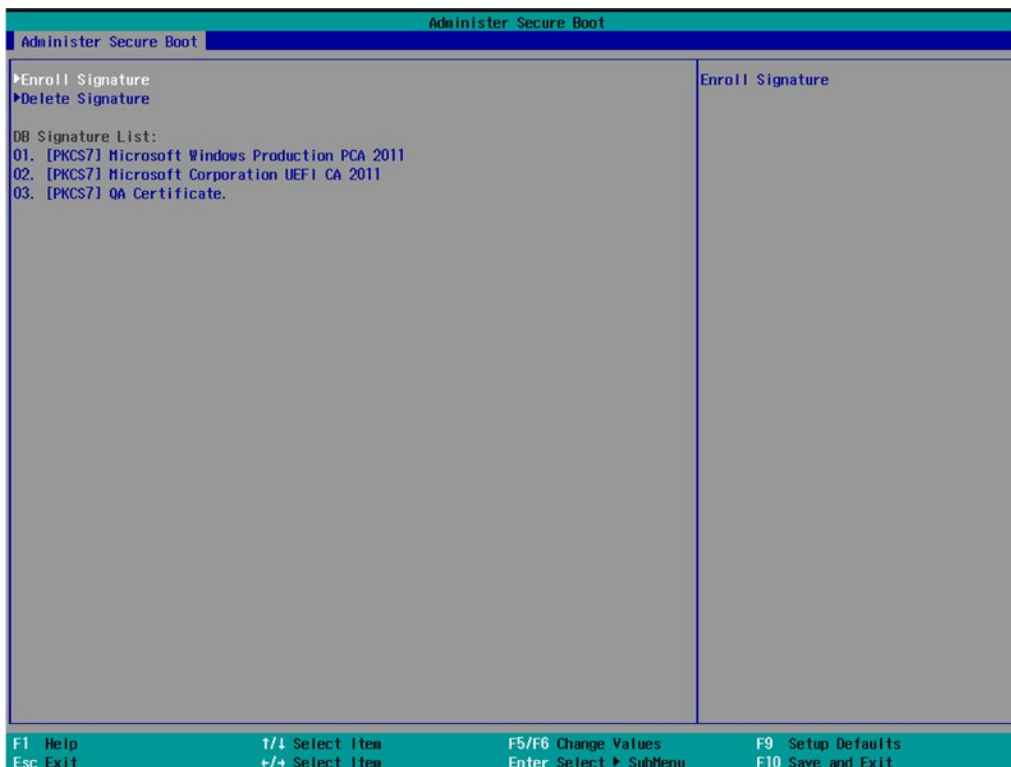
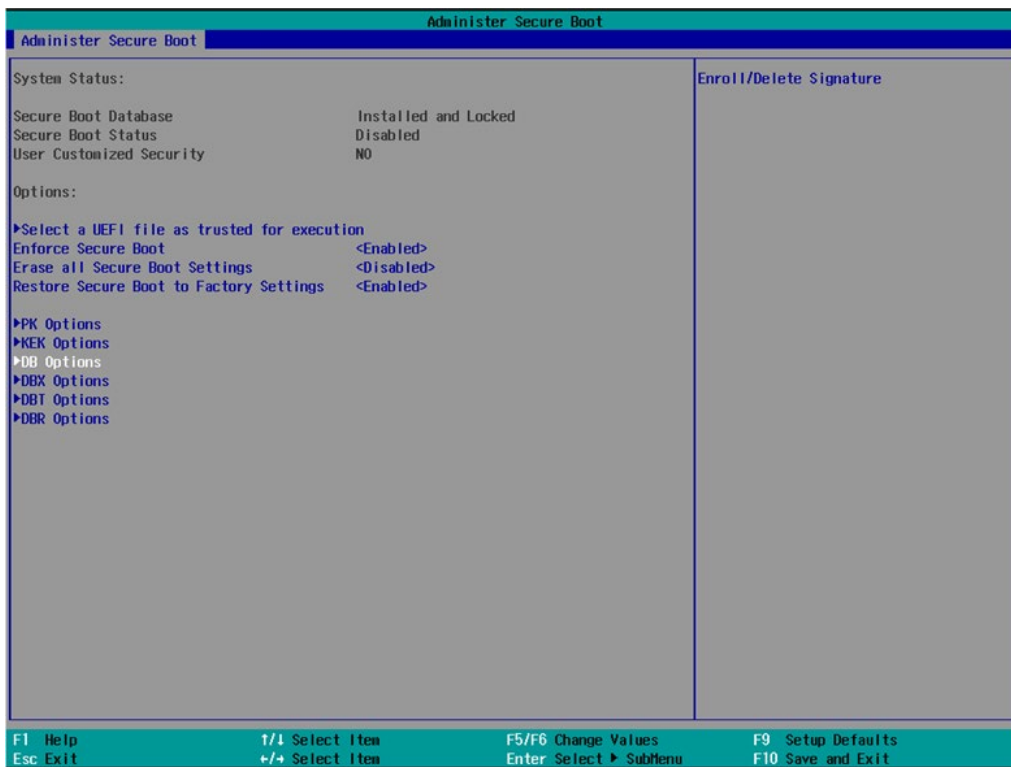

Enter "DB OPTION" and enroll your key. Please make sure your key is CRT format and uses RSA 2048 or better.

# Upgrading the BIOS

This section describes how to upgrade the BIOS on your computer.



## NOTE

It is possible to permanently damage the computer when upgrading the BIOS. We strongly recommend that you contact Moxa's technical support staff for assistance to obtain all the necessary tools and the most current advice before attempting to upgrade the BIOS on any Moxa device.

### Step 1: Create a Bootable USB Disk

Before upgrading the BIOS, you must create a bootable USB drive as a system boot device for use in the future.

1. Insert a USB disk in the computer's USB drive.
2. Search for "format" and select **Create and format hard disk partitions**.

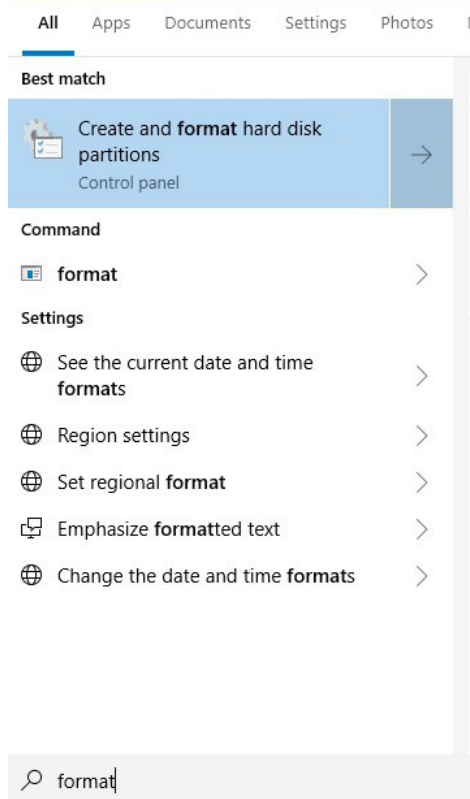

3. Right-click on the USB disk item and select **Format**.

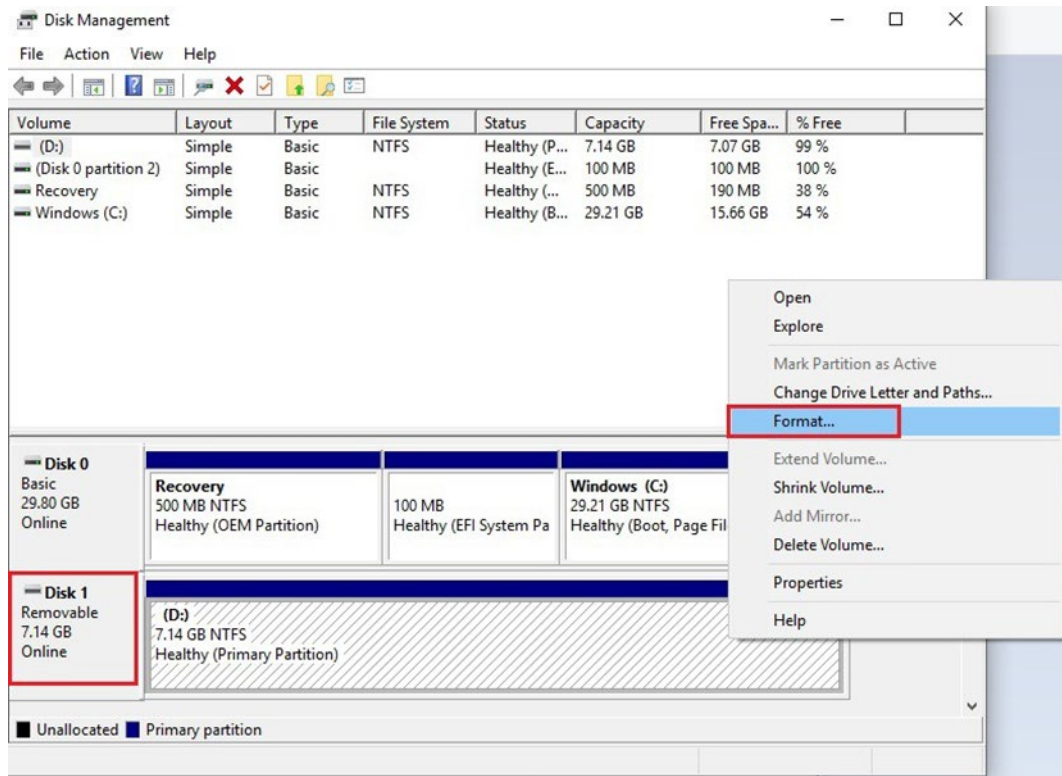

4. Select **FAT32** and click **OK** to start formatting the disk.

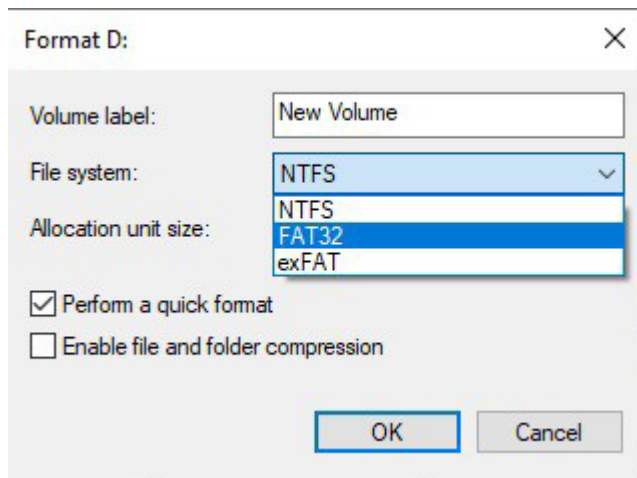

## Step 2: Prepare the Upgrade File

You must use the BIOS upgrade installation file to upgrade the BIOS. Contact Moxa's technical department for assistance. The BIOS upgrade file includes an **efi** folder and an **xxxx.efi** file. Copy the **efi** folder and **xxxx.efi** file to the bootable USB disk.

### Step 3: Run the Upgrade Program on Your Computer

1. Reboot the computer with the boot disk and press F2 to go to the Boot Manager.  
If the BIOS cannot recognize the USB drive as a boot-up device, the USB drive might not have a partition table. Use the Windows command line tool **diskpart** to rebuild the partition table.
2. In the **Boot From File** page, select the corresponding disk.

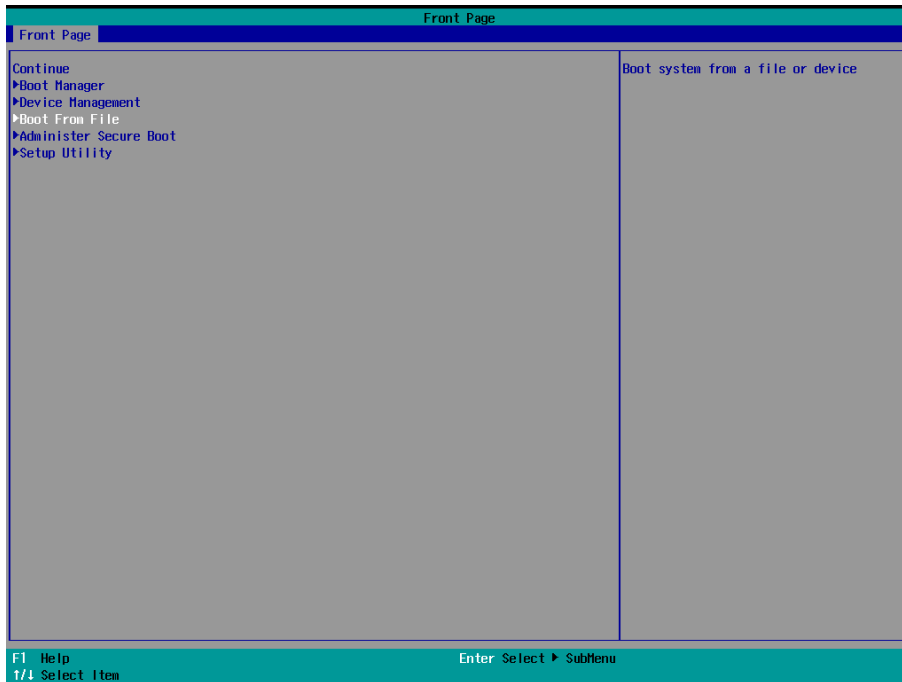

3. elect update file xxxx.efi



4. The process will be starting.

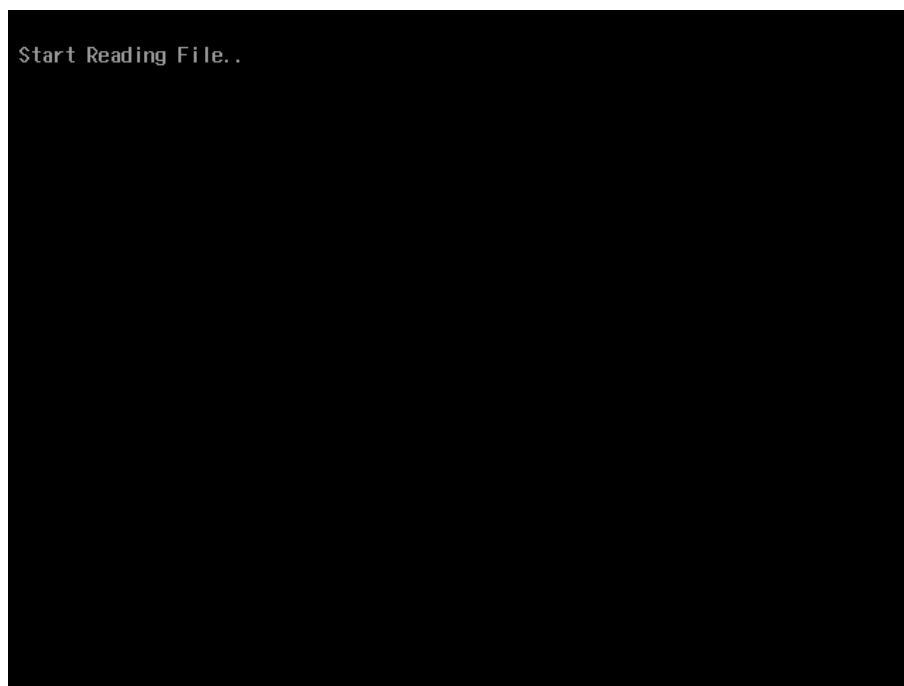

### **ATTENTION**

Do NOT switch off the power supply during the BIOS upgrade, since doing so may cause the system to crash.

```

Insyde H20FFT (Flash Firmware Tool) Version (SEG) 200.00.00.13
Copyright (C) 2020 Insyde Software Corp. All Rights Reserved.

Loading New BIOS Image File: Done

Current BIOS Model Name:
New BIOS Model Name:
Current BIOS Version: V1.0.0S12
New BIOS Version: V1.0.0S12

Common Region:00 StartAddr:0xFE000000 EndAddr:0xFE000FFF
Common Region:01 StartAddr:0xFF400000 EndAddr:0xFFFFFFFF
Updating Block at FE21D000h
0% 25% 50% 75% 100% 6x

```

When the upgrade is finished, the computer will automatically reboot.

You can check the BIOS version on the Main page to confirm the upgrade.

```

Main Advanced Security Power Boot Exit
Project Name
BIOS Version V1.0.0S12

```

If the system has more than one boot device, you will see more than one fsx (x represents the number).

```

EFI Shell version 2.50 [22281.4149]
Current running mode 1.1.2
Device mapping table
fs0 :HardDisk - Alias hd33e0a2 blk0
      PciRoot(0x0)/Pci(0x17,0x0)/Sata(0x4,0x0,0x0)/HD(2,GPT,0AC3B829-99B0-4FDE-844D-8A10C1D55C6C,0xFA000,0x32000)
fs1 :Removable HardDisk - Alias hd25r0b blk1
      PciRoot(0x0)/Pci(0x14,0x0)/USB(0x11,0x0)/HD(1,MBR,0x00DD3D80,0x3F,0xEB5FC1)
fs2 :Removable BlockDevice - Alias f25s0 blk2
      PciRoot(0x0)/Pci(0x14,0x0)/USB(0x12,0x0)
blk0 :HardDisk - Alias hd33e0a2 fs0
      PciRoot(0x0)/Pci(0x17,0x0)/Sata(0x4,0x0,0x0)/HD(2,GPT,0AC3B829-99B0-4FDE-844D-8A10C1D55C6C,0xFA000,0x32000)
blk1 :Removable HardDisk - Alias hd25r0b fs1
      PciRoot(0x0)/Pci(0x14,0x0)/USB(0x11,0x0)/HD(1,MBR,0x00DD3D80,0x3F,0xEB5FC1)
blk2 :Removable BlockDevice - Alias f25s0 fs2
      PciRoot(0x0)/Pci(0x14,0x0)/USB(0x12,0x0)
blk3 :HardDisk - Alias (null)
      PciRoot(0x0)/Pci(0x17,0x0)/Sata(0x4,0x0,0x0)/HD(1,GPT,5796BAEF-EC3F-447F-B4F1-21EB08DC5D57,0x800,0xF9800)
blk4 :HardDisk - Alias (null)
      PciRoot(0x0)/Pci(0x17,0x0)/Sata(0x4,0x0,0x0)/HD(3,GPT,7C8FF3C6-53E8-4CF9-8141-65DF7EF04399,0x12C000,0x8000)
blk5 :HardDisk - Alias (null)
      PciRoot(0x0)/Pci(0x17,0x0)/Sata(0x4,0x0,0x0)/HD(4,GPT,1AABAECB-BE17-4C27-AF60-E6C69977AC02,0x134000,0x3A6E800)
blk6 :BlockDevice - Alias (null)
      PciRoot(0x0)/Pci(0x17,0x0)/Sata(0x4,0x0,0x0)
blk7 :Removable BlockDevice - Alias (null)
      PciRoot(0x0)/Pci(0x14,0x0)/USB(0x11,0x0)

```

5. Go to each fsx (x stands for the number) and type ls to view the content of the boot device. If you find an upgrade file, run it.

```

fs0:\> fs1:
fs1:\> ls
Directory of: fs1:\

06/27/19 11:43a <DIR>          16,384 efi
06/13/19 11:10a              17,974,704 820C100S16 efi
1 File(s) 17,974,704 bytes
1 Dir(s)

```