

AWK-3131A-RTGシリーズ

鉄道列車 - 地上間向けWi-Fi 4 (802.11n) IP30無線AP/クライアント



機能とメリット

- 車載および沿線展開向けM12およびSCファイバーLANコネクタ
- より柔軟な展開を実現するDINレール設計とQMAコネクタ
- 50 ms未満のコントローラベースTurbo Roamingにより、シームレスな列車 - 地上間通信を実現

認証



EN 50155



EN 50121-4



製品紹介

AWK-3131A-RTGシリーズは、信頼性の高い列車 - 地上間 (T2G) 通信を実現するように設計されており、ハンドオーバー時間50ミリ秒未満のコントローラベースTurbo Roamingに対応する、Wi-Fi 4 (802.11n) 鉄道列車 - 地上間IP30保護等級のAP/クライアントです。M12モデルとSSCモデルの両方をラインアップしており、さまざまな導入ニーズに対応し、DINレール設計とQMAアンテナコネクタにより設置を簡素化します。

仕様

WLAN Interface

WLAN Standards	2.4 GHz: 802.11b/g/n with 64 QAM support, 20/40 MHz 5 GHz: 802.11a/n with 64 QAM support, 20/40 MHz
Frequency Band for US (20 MHz operating channels)	AWK-3131A-RTG-US models only: 2.412 to 2.462 GHz (11 channels) 5.180 to 5.240 GHz (4 channels) 5.260 to 5.320 GHz (4 channels) ¹ 5.500 to 5.700 GHz (8 channels) excluding 5.600 to 5.640 GHz ¹ 5.745 to 5.825 GHz (5 channels)
Frequency Band for EU (20 MHz operating channels)	AWK-3131A-RTG-EU models only: 2.412 to 2.472 GHz (13 channels) 5.180 to 5.240 GHz (4 channels) 5.260 to 5.320 GHz (4 channels) ¹ 5.500 to 5.700 GHz (11 channels) ¹
Frequency Band for JP (20 MHz operating channels)	AWK-3131A-RTG-JP models only: 2.412 to 2.484 GHz (14 channels) 5.180 to 5.240 GHz (4 channels) 5.260 to 5.320 GHz (4 channels) ¹ 5.500 to 5.700 GHz (11 channels) ¹
Wireless Security	SSID broadcast enable/disable, WEP encryption (64-bit and 128-bit), WPA/WPA2-Enterprise (IEEE 802.1X/RADIUS, TKIP, AES), WPA/WPA2-Personal
Transmission Rate	802.11b: 1 to 11 Mbps, 802.11a/g: 6 to 54 Mbps, 802.11n: 6.5 to 300 Mbps
Transmitter Power for 802.11a	23±1.5 dBm @ 6 to 24 Mbps, 21±1.5 dBm @ 36 Mbps, 20±1.5 dBm @ 48 Mbps, 18±1.5 dBm @ 54 Mbps

1. DFS (Dynamic Frequency Selection/動的周波数選択) チャンネル対応: APモードでは、レーダー信号が検出された場合、自動的に別のチャンネルへ切り替わります。ただし、規制により、チャンネル切り替え後、サービス開始前には60秒間の利用可能性確認期間が必要です。

Transmitter Power for 802.11n (5 GHz)	23±1.5 dBm @ MCS0 20 MHz, 20±1.5 dBm @ MCS1 20 MHz, 20±1.5 dBm @ MCS2 20 MHz, 20±1.5 dBm @ MCS3 20 MHz, 19±1.5 dBm @ MCS4 20 MHz, 18±1.5 dBm @ MCS5 20 MHz, 18±1.5 dBm @ MCS6 20 MHz, 18±1.5 dBm @ MCS7 20 MHz, 23±1.5 dBm @ MCS8 20 MHz, 20±1.5 dBm @ MCS9 20 MHz, 20±1.5 dBm @ MCS10 20 MHz, 20±1.5 dBm @ MCS11 20 MHz, 19±1.5 dBm @ MCS12 20 MHz, 19±1.5 dBm @ MCS13 20 MHz, 18±1.5 dBm @ MCS14 20 MHz, 18±1.5 dBm @ MCS15 20 MHz, 23±1.5 dBm @ MCS0 40 MHz, 20±1.5 dBm @ MCS1 40 MHz, 20±1.5 dBm @ MCS2 40 MHz, 20±1.5 dBm @ MCS3 40 MHz, 19±1.5 dBm @ MCS4 40 MHz, 18±1.5 dBm @ MCS5 40 MHz, 18±1.5 dBm @ MCS6 40 MHz, 18±1.5 dBm @ MCS7 40 MHz, 23±1.5 dBm @ MCS8 40 MHz, 20±1.5 dBm @ MCS9 40 MHz, 20±1.5 dBm @ MCS10 40 MHz, 20±1.5 dBm @ MCS11 40 MHz, 19±1.5 dBm @ MCS12 40 MHz, 19±1.5 dBm @ MCS13 40 MHz, 18±1.5 dBm @ MCS14 40 MHz, 18±1.5 dBm @ MCS15 40 MHz
Transmitter Power for 802.11b	26±1.5 dBm @ 1 Mbps, 26±1.5 dBm @ 2 Mbps, 26±1.5 dBm @ 5.5 Mbps, 25±1.5 dBm @ 11 Mbps
Transmitter Power for 802.11g	23±1.5 dBm @ 6 to 24 Mbps, 21±1.5 dBm @ 36 Mbps, 19±1.5 dBm @ 48 Mbps, 18±1.5 dBm @ 54 Mbps
Transmitter Power for 802.11n (2.4 GHz)	23±1.5 dBm @ MCS0 20 MHz, 21±1.5 dBm @ MCS1 20 MHz, 21±1.5 dBm @ MCS2 20 MHz, 21±1.5 dBm @ MCS3 20 MHz, 20±1.5 dBm @ MCS4 20 MHz, 19±1.5 dBm @ MCS5 20 MHz, 18±1.5 dBm @ MCS6 20 MHz, 18±1.5 dBm @ MCS7 20 MHz, 23±1.5 dBm @ MCS8 20 MHz, 21±1.5 dBm @ MCS9 20 MHz, 21±1.5 dBm @ MCS10 20 MHz, 21±1.5 dBm @ MCS11 20 MHz, 20±1.5 dBm @ MCS12 20 MHz, 19±1.5 dBm @ MCS13 20 MHz, 18±1.5 dBm @ MCS14 20 MHz, 18±1.5 dBm @ MCS15 20 MHz, 23±1.5 dBm @ MCS0 40 MHz, 20±1.5 dBm @ MCS1 40 MHz, 20±1.5 dBm @ MCS2 40 MHz, 20±1.5 dBm @ MCS3 40 MHz, 19±1.5 dBm @ MCS4 40 MHz, 19±1.5 dBm @ MCS5 40 MHz, 18±1.5 dBm @ MCS6 40 MHz, 17±1.5 dBm @ MCS7 40 MHz, 23±1.5 dBm @ MCS8 40 MHz, 20±1.5 dBm @ MCS9 40 MHz, 20±1.5 dBm @ MCS10 40 MHz, 20±1.5 dBm @ MCS11 40 MHz, 20±1.5 dBm @ MCS12 40 MHz, 19±1.5 dBm @ MCS13 40 MHz, 18±1.5 dBm @ MCS14 40 MHz, 17±1.5 dBm @ MCS15 40 MHz
Receiver Sensitivity for 802.11a (measured at 5.680 GHz)	Typ. -90 @ 6 Mbps, Typ. -88 @ 9 Mbps, Typ. -88 @ 12 Mbps, Typ. -85 @ 18 Mbps, Typ. -81 @ 24 Mbps, Typ. -78 @ 36 Mbps, Typ. -74 @ 48 Mbps, Typ. -74 @ 54 Mbps, Note: Due to a limitation in the receiver sensitivity performance for channels 153 and 161, it is recommended to avoid using these channels in your critical applications.
Receiver Sensitivity for 802.11n (5 GHz; measured at 5.680 GHz)	Typ. -88 dBm @ MCS0 20 MHz, Typ. -85 dBm @ MCS1 20 MHz, Typ. -82 dBm @ MCS2 20 MHz, Typ. -79 dBm @ MCS3 20 MHz, Typ. -76 dBm @ MCS4 20 MHz, Typ. -71 dBm @ MCS5 20 MHz, Typ. -70 dBm @ MCS6 20 MHz, Typ. -69 dBm @ MCS7 20 MHz, Typ. -95 dBm @ MCS8 20 MHz, Typ. -91 dBm @ MCS9 20 MHz, Typ. -87 dBm @ MCS10 20 MHz, Typ. -80 dBm @ MCS11 20 MHz, Typ. -78 dBm @ MCS12 20 MHz, Typ. -74 dBm @ MCS13 20 MHz, Typ. -72 dBm @ MCS14 20 MHz, Typ. -71 dBm @ MCS15 20 MHz, Typ. -84 dBm @ MCS0 40 MHz, Typ. -81 dBm @ MCS1 40 MHz, Typ. -77 dBm @ MCS2 40 MHz, Typ. -75 dBm @ MCS3 40 MHz, Typ. -71 dBm @ MCS4 40 MHz, Typ. -67 dBm @ MCS5 40 MHz, Typ. -64 dBm @ MCS6 40 MHz, Typ. -63 dBm @ MCS7 40 MHz, Typ. -90 dBm @ MCS8 40 MHz, Typ. -85 dBm @ MCS9 40 MHz, Typ. -82 dBm @ MCS10 40 MHz, Typ. -81 dBm @ MCS11 40 MHz, Typ. -77 dBm @ MCS12 40 MHz, Typ. -73 dBm @ MCS13 40 MHz, Typ. -71 dBm @ MCS14 40 MHz, Note: Due to a limitation in the receiver sensitivity performance for channels 153 and 161, it is recommended to avoid using these channels in your critical applications., Typ. -68 dBm @ MCS15 40 MHz
Receiver Sensitivity for 802.11b (measured at 2.437 GHz)	Typ. -93 dBm @ 1 Mbps, Typ. -93 dBm @ 2 Mbps, Typ. -93 dBm @ 5.5 Mbps, Typ. -88 dBm @ 11 Mbps
Receiver Sensitivity for 802.11g (measured at 2.437 GHz)	Typ. -88 dBm @ 6 Mbps, Typ. -86 dBm @ 9 Mbps, Typ. -85 dBm @ 12 Mbps, Typ. -85 dBm @ 18 Mbps, Typ. -85 dBm @ 24 Mbps, Typ. -82 dBm @ 36 Mbps, Typ. -78 dBm @ 48 Mbps, Typ. -74 dBm @ 54 Mbps
Receiver Sensitivity for 802.11n (2.4 GHz; measured at 2.437 GHz)	Typ. -89 dBm @ MCS0 20 MHz, Typ. -85 dBm @ MCS1 20 MHz, Typ. -85 dBm @ MCS2 20 MHz, Typ. -82 dBm @ MCS3 20 MHz, Typ. -78 dBm @ MCS4 20 MHz, Typ. -74 dBm @ MCS5 20 MHz, Typ. -72 dBm @ MCS6 20 MHz, Typ. -70 dBm @ MCS7 20 MHz, Typ. -95 dBm @ MCS8 20 MHz, Typ. -90 dBm @ MCS9 20 MHz, Typ. -87 dBm @ MCS10 20 MHz, Typ. -83 dBm @ MCS11 20 MHz, Typ. -80 dBm @ MCS12 20 MHz, Typ. -74 dBm @ MCS13 20 MHz, Typ. -71 dBm @ MCS14 20 MHz, Typ. -69 dBm @ MCS15 20 MHz, Typ. -87 dBm @ MCS0 40 MHz, Typ. -83 dBm @ MCS1 40 MHz, Typ. -83 dBm @ MCS2 40 MHz, Typ. -80 dBm @ MCS3 40 MHz, Typ. -76 dBm @ MCS4 40 MHz, Typ. -73 dBm @ MCS5 40 MHz, Typ. -69 dBm @ MCS6 40 MHz, Typ. -67 dBm @ MCS7 40 MHz, Typ. -93 dBm @ MCS8 40 MHz, Typ. -88 dBm @ MCS9 40 MHz, Typ. -85 dBm @ MCS10 40 MHz, Typ. -82 dBm @ MCS11 40 MHz, Typ. -78 dBm @ MCS12 40 MHz, Typ. -73 dBm @ MCS13 40 MHz, Typ. -69 dBm @ MCS14 40 MHz, Typ. -67 dBm @ MCS15 40 MHz

WLAN Operation Mode	Access point, Client, Client-Router, Sniffer														
Antenna Connectors	2 x QMA														
Ethernet Interface															
Standards	IEEE 802.3 for 10BaseT, IEEE 802.3u for 100BaseT(X), IEEE 802.3af for PoE, IEEE 802.1Q for VLAN Tagging														
10/100BaseT(X) Ports (M12 D-coded 4-pin female connector)	AWK-3131A-M12-RTG models: 1 Supports IEEE 802.3af PoE														
100BaseFX Ports (single-mode SC connector)	AWK-3131A-SSC-RTG models: 1														
Optical Fiber	<table border="1"> <thead> <tr> <th></th> <th>100BaseFX</th> </tr> </thead> <tbody> <tr> <td>Wavelength</td> <td>1310 nm</td> </tr> <tr> <td>Max. TX</td> <td>0 dBm</td> </tr> <tr> <td>Min. TX</td> <td>-5 dBm</td> </tr> <tr> <td>RX Sensitivity</td> <td>-34 dBm</td> </tr> <tr> <td>Link Budget</td> <td>29 dB</td> </tr> <tr> <td>Typical Distance</td> <td>40 km</td> </tr> </tbody> </table>		100BaseFX	Wavelength	1310 nm	Max. TX	0 dBm	Min. TX	-5 dBm	RX Sensitivity	-34 dBm	Link Budget	29 dB	Typical Distance	40 km
	100BaseFX														
Wavelength	1310 nm														
Max. TX	0 dBm														
Min. TX	-5 dBm														
RX Sensitivity	-34 dBm														
Link Budget	29 dB														
Typical Distance	40 km														
Ethernet Software Features															
Management	SNMPv1/v2c/v3, Proxy ARP, ARP, DNS, HTTP, HTTPS, ICMP, TCP/IP, UDP, RADIUS, DHCP, BOOTP, STP/RSTP (IEEE 802.1D/w)														
Security	RADIUS														
Time Management	SNTP														
LED Interface															
LED Indicators	All models: PWR1, PWR2, FAULT, STATE, SIGNAL, CLIENT, WLAN AWK-3131A-M12-RTG models only: PoE, LAN AWK-3131A-SSC-RTG models only: 100M														
Firewall															
Filter	IP protocol, MAC address, Port-based														
Serial Interface															
Console Port	RS-232 (RJ45-type)														
Input/Output Interface															
Digital Inputs	2, +13 to +30 V for state 1, +3 to -30 V for state 0, Max. input current: 8 mA														
Alarm Contact Channels	Relay output with current carrying capacity of 1 A @ 24 VDC														
Buttons	Reset button														
Physical Characteristics															
Housing	Metal														
IP Rating	IP30														
Dimensions	52.9 x 151.9 x 127.4 mm (2.08 x 5.98 x 5.02 in)														
Weight	850 g (1.87 lb)														
Installation	DIN-rail mounting, Wall mounting (with optional kit)														

Power Parameters

Input Current	AWK-3131A-M12-RTG models: 0.85 A @ 12 VDC, 0.22 A @ 48 VDC AWK-3131A-SSC-RTG models: 1.0 A @ 12 VDC, 0.27 A @ 48 VDC
Input Voltage	12 to 48 VDC, Redundant dual inputs, 48 VDC Power over Ethernet
Power Connector	1 removable 10-contact terminal block(s)
Power Consumption	AWK-3131A-M12-RTG models: 10.5 W (max.) AWK-3131A-SSC-RTG models: 13 W (max.)
Reverse Polarity Protection	Supported

Environmental Limits

Operating Temperature	-40 to 75°C (-40 to 167°F)
Storage Temperature (package included)	-40 to 85°C (-40 to 185°F)
Ambient Relative Humidity	5 to 95% (non-condensing)

Standards and Certifications

EMC	EN 61000-6-2/-6-4
EMI	CISPR 32, FCC Part 15B Class B
EMS	IEC 61000-4-2 ESD: Contact: 8 kV; Air: 15 kV, IEC 61000-4-3 RS: 80 MHz to 1 GHz: 20 V/m, IEC 61000-4-4 EFT: Power: 2 kV; Signal: 2 kV, IEC 61000-4-5 Surge: Power: 2 kV; Signal: 2 kV, IEC 61000-4-6 CS: 10 V, IEC 61000-4-8
Cybersecurity	EN 18031-1
Railway	EN 50155, EN 50121-4
Railway Fire Protection	EN 45545-2
Radio	EN 301 489-1/17, EN 300 328, EN 301 893, MIC, FCC ID SLE-WAPN008, SRRC, NCC, IDA
Safety	UL 60950-1, IEC 60950-1, EN 60950-1 (LVD)

MTBF

Time	AWK-3131A-M12-RTG models: 552,454 hrs AWK-3131A-SSC-RTG models: 528,478 hrs
Standards	Telcordia Standard SR-332

Warranty

Warranty Period	5 years
Details	See www.moxa.com/jp/warranty

Package Contents

Device	1 x AWK-3131A-RTG wireless AP/client
Installation Kit	1 x DIN-rail kit, 2 x cap, plastic, for RJ45 port, 1 plastic protective cap for fiber port (AWK-3131A-SSC-RTG only), 1 x cable holder with screw
Documentation	1 x quick installation guide, 1 x warranty card

寸法

AWK-3131A-M12-RTGモデル

単位：mm（インチ）

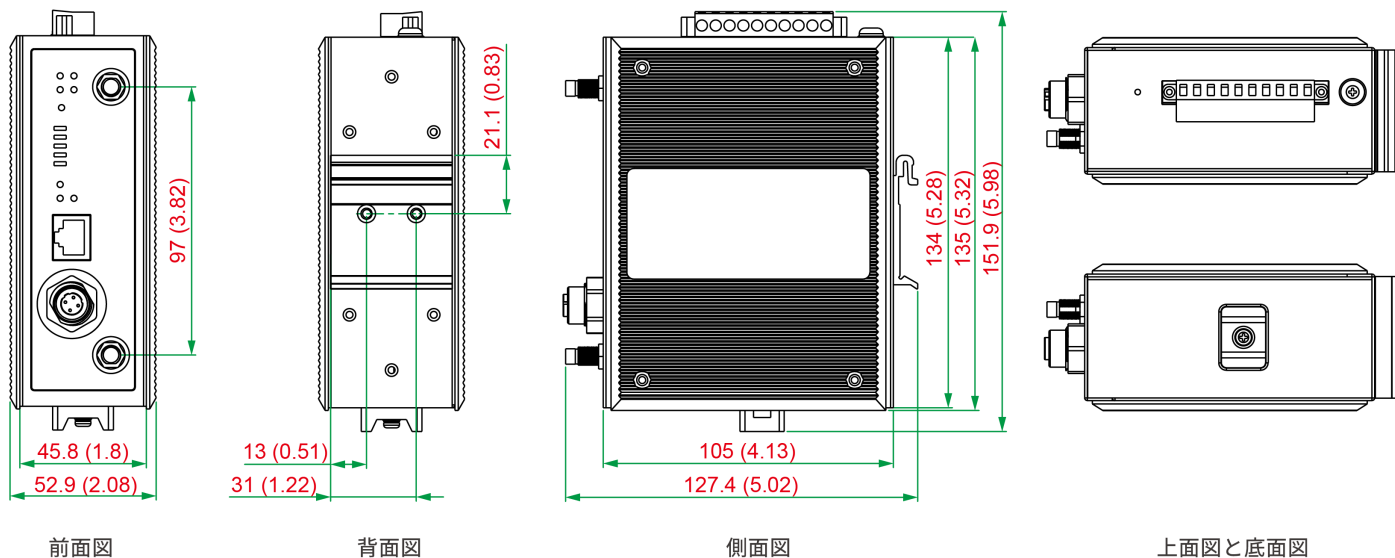

AWK-3131A-SCC-RTGモデル

単位：mm（インチ）

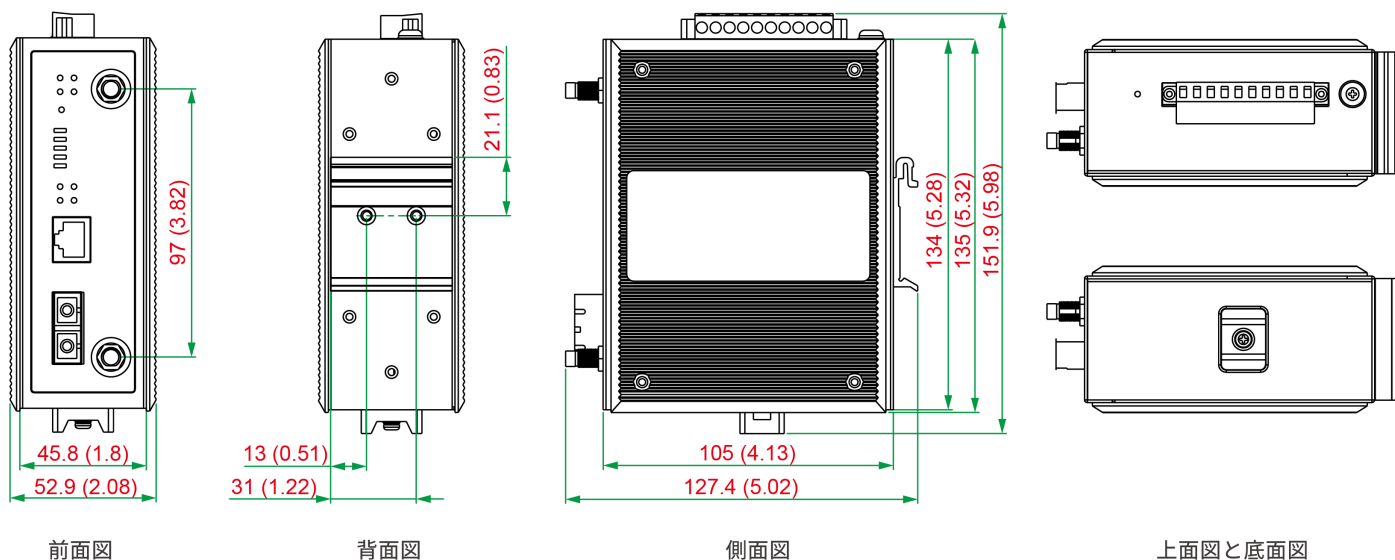

注文情報

Model Name	Band	Connector	Conformal Coating
AWK-3131A-M12-RTG-EU-T	EU	M12	-
AWK-3131A-M12-RTG-US-T	US	M12	-
AWK-3131A-M12-RTG-JP-T	JP	M12	-
AWK-3131A-M12-RTG-EU-CT-T	EU	M12	P
AWK-3131A-M12-RTG-US-CT-T	US	M12	P
AWK-3131A-M12-RTG-JP-CT-T	JP	M12	P
AWK-3131A-SSC-RTG-EU-T	EU	Single-mode SC	-
AWK-3131A-SSC-RTG-US-T	US	Single-mode SC	-

Model Name	Band	Connector	Conformal Coating
AWK-3131A-SSC-RTG-JP-T	JP	Single-mode SC	-
AWK-3131A-SSC-RTG-EU-CT-T	EU	Single-mode SC	P
AWK-3131A-SSC-RTG-US-CT-T	US	Single-mode SC	P
AWK-3131A-SSC-RTG-JP-CT-T	JP	Single-mode SC	P

アクセサリ（別売）

Wall-Mounting Kits

WK-51-01	Wall mounting kit with 2 plates (51.6 x 67 x 2 mm) and 6 screws
----------	---

© Moxa Inc. All rights reserved. 2026年1月23日更新。

Moxa Inc.の明白な許可を written で取得しない限り、本書およびその一部の複製や使用はいかなる方法やいかなる場合でも許可されません。製品の仕様は予告なく変更されることがあります。最新の製品情報については当社のWebサイトをご覧ください。