

# EDS-4009 Series

## 9-port managed Ethernet switches



### Features and Benefits

- Turbo Ring and Turbo Chain (recovery time < 20 ms @ 250 switches)<sup>1</sup>, and RSTP/STP for network redundancy
- Wide range of power input options for flexible deployment
- Compact and flexible housing design to fit into confined spaces
- Supports MXstudio for easy, visualized industrial network management
- IEC 62443-4-2 Security Level 2 certified
- Marine cybersecurity certified (IACS UR E27 Rev.1, IEC 61162-460 Ed. 3.0 for switch role)

### Certifications



## Introduction

The EDS-4009 Series is a range of 9-port managed Fast Ethernet switches with the option for three 100M ST/SC fiber-optic ports.

Redundant Ethernet technologies such as Turbo Ring, Turbo Chain, and RSTP/STP increase the reliability of your system and improve the availability of your network backbone. The EDS-4009 Series is designed specifically for demanding applications such as video and process monitoring, ITS, and DCS systems, all of which can benefit from a scalable backbone.

### IEC 62443-4-2 Security Level 2 Certified

EDS-(G)4000 Series models are IEC 62443-4-2 Security Level 2 certified (<https://certificates.iecee.org/#/deliverables/CERT/1605016/view>) helping our customers meet the compliance requirements of secure industrial network design.

## Specifications

### Ethernet Interface

10/100BaseT(X) Ports (RJ45 connector)	6 Auto negotiation speed Full/Half duplex mode Auto MDI/MDI-X connection
100BaseFX Ports (multi-mode SC connector)	EDS-4009-3MSC-LV/-HV/-T models: 3
100BaseFX Ports (multi-mode ST connector)	EDS-4009-3MST-LV/-HV/-T models: 3
100BaseFX Ports (single-mode SC connector)	EDS-4009-3SSC-LV/-HV/-T models: 3

1. If the port link speed is 1 Gigabit or higher, the recovery time is < 50 ms.

Standards	IEEE 802.3 for 10BaseT IEEE 802.3u for 100BaseT(X) and 100BaseFX IEEE 802.3x for flow control IEEE 802.3ad for Port Trunk with LACP IEEE 802.1Q for VLAN Tagging IEEE 802.1D-2004 for Spanning Tree Protocol IEEE 802.1w for Rapid Spanning Tree Protocol IEEE 802.1p for Class of Service IEEE 802.1X for authentication																																						
Optical Fiber	<table border="1"> <thead> <tr> <th colspan="2" rowspan="2"></th> <th colspan="2">100BaseFX</th> </tr> <tr> <th>Multi-Mode</th> <th>Single-Mode</th> </tr> <tr> <th rowspan="2">Fiber Cable Type</th> <th rowspan="2">OM1</th> <th>50/125 μm</th> <th rowspan="2">G.652</th> </tr> <tr> <th>800 MHz x km</th> </tr> </thead> <tbody> <tr> <td colspan="2">Typical Distance</td> <td>4 km</td> <td>40 km</td> </tr> <tr> <td rowspan="3">Wavelength</td> <td>Typical (nm)</td> <td colspan="2">1300</td> </tr> <tr> <td>TX Range (nm)</td> <td>1260 to 1360</td> <td>1280 to 1340</td> </tr> <tr> <td>RX Range (nm)</td> <td>1100 to 1600</td> <td>1100 to 1600</td> </tr> <tr> <td rowspan="4">Optical Power</td> <td>TX Range (dBm)</td> <td>-10 to -20</td> <td>0 to -5</td> </tr> <tr> <td>RX Range (dBm)</td> <td>-3 to -32</td> <td>-3 to -34</td> </tr> <tr> <td>Link Budget (dB)</td> <td>12</td> <td>29</td> </tr> <tr> <td>Dispersion Penalty (dB)</td> <td>3</td> <td>1</td> </tr> </tbody> </table> <p>Note: When connecting a single-mode fiber transceiver, we recommend using an attenuator to prevent damage caused by excessive optical power.          Note: Compute the “typical distance” of a specific fiber transceiver as follows: Link budget (dB) &gt; dispersion penalty (dB) + total link loss (dB).</p>			100BaseFX		Multi-Mode	Single-Mode	Fiber Cable Type	OM1	50/125 μm	G.652	800 MHz x km	Typical Distance		4 km	40 km	Wavelength	Typical (nm)	1300		TX Range (nm)	1260 to 1360	1280 to 1340	RX Range (nm)	1100 to 1600	1100 to 1600	Optical Power	TX Range (dBm)	-10 to -20	0 to -5	RX Range (dBm)	-3 to -32	-3 to -34	Link Budget (dB)	12	29	Dispersion Penalty (dB)	3	1
				100BaseFX																																			
		Multi-Mode	Single-Mode																																				
Fiber Cable Type	OM1	50/125 μm	G.652																																				
		800 MHz x km																																					
Typical Distance		4 km	40 km																																				
Wavelength	Typical (nm)	1300																																					
	TX Range (nm)	1260 to 1360	1280 to 1340																																				
	RX Range (nm)	1100 to 1600	1100 to 1600																																				
Optical Power	TX Range (dBm)	-10 to -20	0 to -5																																				
	RX Range (dBm)	-3 to -32	-3 to -34																																				
	Link Budget (dB)	12	29																																				
	Dispersion Penalty (dB)	3	1																																				

### Ethernet Software Features

Industrial Protocols	EtherNet/IP Modbus TCP PROFINET IO Device
Management	IPv4/IPv6 Flow control Back Pressure Flow Control DHCP Server/Client ARP RARP LLDP Fiber check Port Mirroring (SPAN, RSPAN) Linkup Delay SMTP SNMP Trap SNMP Inform SNMPv1/v2c/v3 RMON TFTP SFTP HTTP HTTPS Telnet Syslog Private MIB
Filter	GMRP GVRP GARP 802.1Q VLAN IGMP Snooping v1/v2/v3

	IGMP Querier
Redundancy Protocols	STP RSTP Turbo Ring v2 Turbo Chain Ring Coupling Dual-Homing Link Aggregation MRP MSTP
Security	Broadcast storm protection Rate Limit Trust access control Static Port Lock MAC Sticky HTTPS/SSL SSH RADIUS TACACS+ Access control list Login and Password Policy DHCP Snooping
Time Management	SNTP NTP Server/Client NTP Authentication IEEE 1588v2 PTP (hardware-based) Supported power profiles: IEEE 1588 Default 2008, IEC 61850-9-3-2016, IEEE C37.238-2017
Protocols	IPv4/IPv6 TCP/IP UDP ICMP ARP RARP TFTP DNS NTP Client DHCP Server DHCP Client 802.1X QoS HTTPS HTTP Telnet SMTP SNMPv1/v2c/v3 RMON Syslog
MIB	P-BRIDGE MIB Q-BRIDGE-MIB IEEE8021-SPANNING-TREE-MIB IEEE8021-PAE-MIB IEEE8023-LAG-MIB LLDP-EXT-DOT1-MIB LLDP-EXT-DOT3-MIB SNMPv2-MIB RMON MIB Groups 1, 2, 3, 9
<b>Switch Properties</b>	
MAC Table Size	16 K
Jumbo Frame Size	9.216 KB
Max. No. of VLANs	256
VLAN ID Range	VID 1 to 4094

IGMP Groups	512
Priority Queues	4
Packet Buffer Size	1 MB
<b>LED Interface</b>	
LED Indicators	PWR1, PWR2, STATE, FAULT, MSTR/HEAD, CPLR/TAIL, SYNC
<b>Serial Interface</b>	
Console Port	RS-232 (TxD, RxD, GND), 8-pin RJ45 (115200, n, 8, 1)
<b>USB Interface</b>	
USB Connector	USB Type A (Reserved)
<b>Input/Output Interface</b>	
Alarm Contact Channels	1, Relay output with current carrying capacity of 1 A @ 24 VDC
Digital Input Channels	1
Digital Inputs	+13 to +30 V for state 1 -30 to +3 V for state 0 Max. input current: 8 mA
Buttons	Reset button
<b>DIP Switch Configuration</b>	
DIP Switches	Turbo Ring, Master, Coupler, Reserve
<b>Power Parameters</b>	
Connection	2 removable 4-contact terminal block(s)
Pre-installed Power Module	-LV/-LV-T models: PWR-100-LV -HV/-HV-T models: PWR-105-HV-I
Note	The EDS-4009 Series supports modular power supplies. The model names and power parameters are determined by the installed power module.  For example: EDS-4009-T + PWR-100-LV = EDS-4009-LV-T EDS-4009-T + PWR-105-HV-I = EDS-4009-HV-T  If you install a different power module, refer to the specifications of the corresponding model. For example, if you replace the power module of the EDS-4009-LV-T with the PWR-105-HV-I, refer to the specifications of the EDS-4009-HV-T.
Input Voltage	-LV/-LV-T models: 12/24/48 VDC, Redundant dual inputs -HV/-HV-T models: 110/220 VDC/VAC, Single input
Operating Voltage	-LV/-LV-T models: 9.6 to 60 VDC -HV/-HV-T models: 88 to 300 VDC, 85 to 264 VAC
Input Current	-LV/-LV-T models: 12-48 VDC, 1.50-0.40 A or 24 VDC, 0.70 A -HV/-HV-T models: 110-220 VAC, 50-60 Hz, 0.30-0.20 A or 110-220 VDC, 0.30-0.20 A
Power Consumption (Max.)	EDS-4009-3MSC-LV(-T) models: 9.51 W EDS-4009-3MSC-HV(-T) models: 12.14 W EDS-4009-3MST-LV(-T) models: 9.51 W EDS-4009-3MST-HV(-T) models: 12.17 W EDS-4009-3SSC-LV(-T) models: 9.51 W EDS-4009-3SSC-HV(-T) models: 12.34 W
Overload Current Protection	Supported
Reverse Polarity Protection	Supported

## Physical Characteristics

IP Rating	IP40
Dimensions	EDS-4009-3MSC(-T)/EDS-4009-3SSC(-T) models: 55 x 140 x 120 mm (2.17 x 5.51 x 4.72 in) EDS-4009-3MST(-T) models: 55 x 140 x 132 mm (2.17 x 5.51 x 5.20 in)
Weight	EDS-4009-3MSC(-T) models: 821.5 g (1.81 lb) EDS-4009-3MST(-T) models: 920 g (2.03 lb) EDS-4009-3SSC(-T) models: 932 g (2.05 lb)
Installation	DIN-rail mounting Wall mounting (with optional kit)
Housing	Metal

## Environmental Limits

Operating Temperature	Standard Models: -10 to 60°C (14 to 140°F) Wide Temp. Models: -40 to 75°C (-40 to 167°F)
Storage Temperature (package included)	-40 to 85°C (-40 to 185°F)
Ambient Relative Humidity	5 to 95% (non-condensing)

## Standards and Certifications

Cybersecurity	IEC 62443-4-2 Security Level 2 IEC 61162-460 (switch role)
Safety	UL 61010-2-201 EN 62368-1 (LVD)
EMC	EN 55032/35 EN 61000-6-2/-6-4
EMI	CISPR 32, FCC Part 15B Class A
EMS	IEC 61000-4-2 ESD: Contact: 8 kV; Air: 15 kV IEC 61000-4-3 RS: 80 MHz to 1 GHz: 20 V/m IEC 61000-4-4 EFT: Power: 4 kV; Signal: 4 kV IEC 61000-4-5 Surge: Power: 4 kV; Signal: 4 kV IEC 61000-4-6 CS: 10 V IEC 61000-4-8 PFMF
Maritime	-LV/-LV-T models: DNV, ABS, NK, LR
Vibration	IEC 60068-2-6
Shock	IEC 60068-2-27
Freefall	IEC 60068-2-32
Railway	EN 50121-4
Traffic Control	NEMA TS2
Power Substation	IEC 61850-3 IEEE 1613 Class 1
Hazardous Locations	-LV/-LV-T models: ATEX IECEX Class I Division 2

## MTBF

Time	EDS-4009-3MSC-LV/-LV-T models: 972,841 hrs EDS-4009-3MSC-HV/-HV-T models: 482,263 hrs EDS-4009-3MST-LV/-LV-T models: 972,841 hrs EDS-4009-3MST-HV/-HV-T models: 482,263 hrs EDS-4009-3SSC-LV/-LV-T models: 972,841 hrs EDS-4009-3SSC-HV/-HV-T models: 482,263 hrs
------	--

## Warranty

Warranty Period	5 years
Details	See <a href="http://www.moxa.com/warranty">www.moxa.com/warranty</a>

## Package Contents

Device	1 x EDS-4009 Series switch
Documentation	1 x quick installation guide 1 x product notice, Simplified Chinese 1 x product certificates of quality inspection, Simplified Chinese 1 x warranty card

## Dimensions

### EDS-4009-3MSC(-T), EDS-4009-3SSC(-T) Models

Unit: mm (inch)

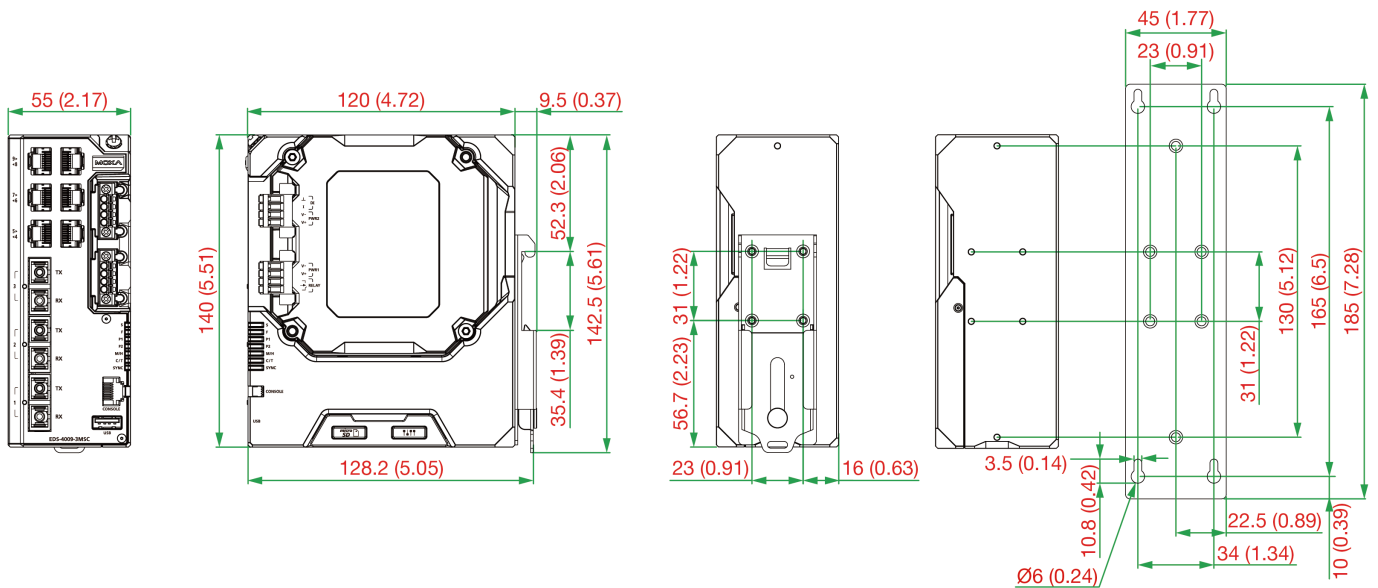

## EDS-4009-3MST(-T) Models

Unit: mm (inch)

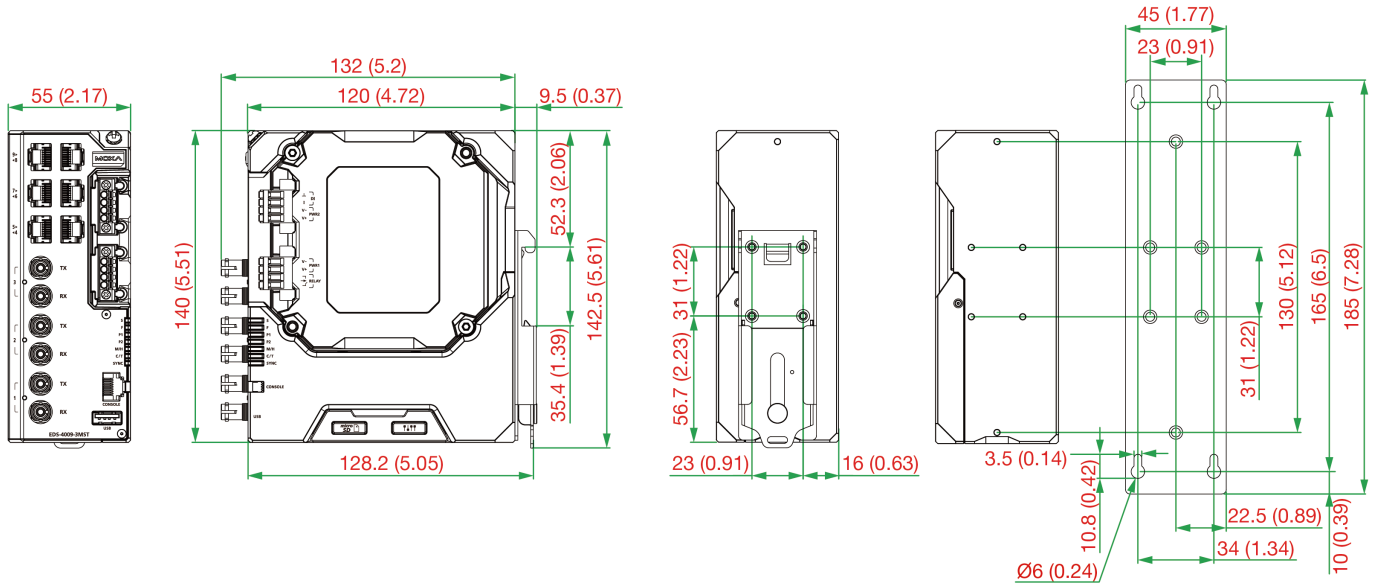

## Ordering Information

Model Name	10/100BaseT(X) Ports (RJ45 Connector)	100BaseFX Ports (Multi-mode SC Connector)	100BaseFX Ports (Multi-mode ST Connector)	100BaseFX Ports (Single-mode SC Connector)	Operating Voltage	Pre-installed Power Module	Operating Temp.
EDS-4009-3MSC-LV	6	3	-	-	9.6 to 60 VDC	PWR-100-LV	-10 to 60°C
EDS-4009-3MSC-LV-T	6	3	-	-	9.6 to 60 VDC	PWR-100-LV	-40 to 75°C
EDS-4009-3MSC-HV	6	3	-	-	88 to 300 VDC, 85 to 264 VAC	PWR-105-HV-I	-10 to 60°C
EDS-4009-3MSC-HV-T	6	3	-	-	88 to 300 VDC, 85 to 264 VAC	PWR-105-HV-I	-40 to 75°C
EDS-4009-3MST-LV	6	-	3	-	9.6 to 60 VDC	PWR-100-LV	-10 to 60°C
EDS-4009-3MST-LV-T	6	-	3	-	9.6 to 60 VDC	PWR-100-LV	-40 to 75°C
EDS-4009-3MST-HV	6	-	3	-	88 to 300 VDC, 85 to 264 VAC	PWR-105-HV-I	-10 to 60°C
EDS-4009-3MST-HV-T	6	-	3	-	88 to 300 VDC, 85 to 264 VAC	PWR-105-HV-I	-40 to 75°C
EDS-4009-3SSC-LV	6	-	-	3	9.6 to 60 VDC	PWR-100-LV	-10 to 60°C
EDS-4009-3SSC-LV-T	6	-	-	3	9.6 to 60 VDC	PWR-100-LV	-40 to 75°C
EDS-4009-3SSC-HV	6	-	-	3	88 to 300 VDC, 85 to 264 VAC	PWR-105-HV-I	-10 to 60°C
EDS-4009-3SSC-HV-T	6	-	-	3	88 to 300 VDC, 85 to 264 VAC	PWR-105-HV-I	-40 to 75°C

## Accessories (sold separately)

### Storage Kits

ABC-02-USB	Configuration backup and restoration tool, firmware upgrade, and log file storage tool for managed Ethernet switches and routers, 0 to 60°C operating temperature
ABC-02-USB-T	Configuration backup and restoration tool, firmware upgrade, and log file storage tool for managed Ethernet switches and routers, -40 to 75°C operating temperature
ABC-03-microSD-T	MicroSD-based configuration backup and restoration tool, firmware upgrades, and log file storage tool for managed Ethernet switches and WLAN products, -40 to 85°C operating temperature

## Power Supplies

HDR-60-24	60 W/2.5 A DIN-rail 24 VDC power supply, universal 85 to 264 VAC or 120 to 370 VDC input voltage, -30 to 70°C operating temperature
NDR-120-24	120 W/5.0 A DIN-rail 24 VDC power supply, universal 90 to 264 VAC or 127 to 370 VDC input voltage, -20 to 70°C operating temperature
NDR-120-48	120 W/2.5 A DIN-rail 48 VDC power supply, universal 90 to 264 VAC or 127 to 370 VDC input voltage, -20 to 70°C operating temperature
NDR-240-48	240 W/5.0 A DIN-rail 48 VDC power supply, universal 90 to 264 VAC or 127 to 370 VDC input voltage, -20 to 70°C operating temperature
MDR-40-24	DIN-rail 24 VDC power supply with 40W/1.7A, 85 to 264 VAC, or 120 to 370 VDC input, -20 to 70°C operating temperature
MDR-60-24	DIN-rail 24 VDC power supply with 60W/2.5A, 85 to 264 VAC, or 120 to 370 VDC input, -20 to 70°C operating temperature

## Software

LIC-MXviewOne-NEW-XN-SR	MXview One node license with customizable node quantity (minimum 1 node)
-------------------------	--

© Moxa Inc. All rights reserved. Updated May 29, 2026.

This document and any portion thereof may not be reproduced or used in any manner whatsoever without the express written permission of Moxa Inc. Product specifications subject to change without notice. Visit our website for the most up-to-date product information.