

# AWK-4131Aシリーズ

## 屋外産業用IEEE 802.11a/b/g/n 無線AP/クライアント



### 機能と特長

- 2x2 MIMO 802.11a/b/g/n AP/クライアント
- ミリ秒レベルクライアントベースのTurbo Roaming<sup>1</sup>
- AeroMagを使った簡単なセットアップ
- AeroLink保護により無線ネットワークの冗長性を確保
- ネットワークアドレス変換(NAT)を使用した簡単なネットワーク設定
- 統合型アンテナと電源に絶縁を施した頑丈な産業用設計
- 屋外での使用向けに設計されたIP68規格の防水・防塵ハウジングと-40~75°Cの広い動作温度範囲
- 5 GHz DFSチャネルサポートにより無線の輻輳を回避

### 認証



### 製品紹介

AWK-4131A IP68屋外産業用AP/クライアントは、802.11nテクノロジーに対応し、最大300 Mbpsのネットデータ速度に対応した2X2 MIMO通信を可能にすることで、増大する高速データ転送に対するニーズを満たしています。AWK-4131Aは、動作温度、電源入力電圧、サージ、ESD、振動において産業規格および認証に準拠しています。AWK-4131Aは2つの冗長DC電源入力により電源の信頼性が高められており、PoE経由により電力を供給することができるため容易に導入することができます。AWK-4131Aは、2.4 GHzまたは5 GHz帯域のいずれかで動作することができ、将来の無線投資を見据えて、既存の802.11a/b/g対応機器と下位互換性があります。MXviewネットワーク管理ユーティリティのワイヤレスアドオンは、AWKの目に見えないワイヤレス接続を可視化し、施設内の隅々までWi-Fi接続を確保します。

### 高度な802.11n産業用無線ソリューション

- 802.11a/b/g/nに準拠したAP/クライアントによる柔軟な導入
- 長距離無線通信に最適化されたソフトウェアにより、最大1kmの見通し距離での通信が可能です（高利得アンテナは5GHz帯のみ対応）
- 60台のクライアントの同時接続に対応
- DFSチャネルサポートにより、既存の無線インフラストラクチャからの干渉を回避するために、より広範囲の5 GHzチャネル選択が可能

### ミッションクリティカルなアプリケーション用の高度な無線テクノロジー

- クライアントベースのTurbo Roaming付きのシームレスローミング<sup>1</sup>AP間のローミングリカバリ時間が150 ms未満の場合(クライアントモード)
- AeroMag は、産業用アプリケーションの基本的な WLAN 設定をエラーなくセットアップするサポートを提供
- AeroLink 保護をサポートし、APとクライアント間の冗長無線リンクを構築（復旧時間 < 300 ms）

### 産業用の耐久性

- 外部からの電氣的干渉に対して500 V絶縁保護設計が施された統合型アンテナと電源
- 屋外の天候に対して保護を提供するIP68保護等級の金属製筐体
- 過酷な環境でもスムーズな無線通信を実現する-40~75°Cの広い動作温度モデル

### MXview Wirelessを使った無線ネットワーク管理

- ダイナミックポロジュービューでは、ワイヤレスリンクのステータスと接続の変更が一目で確認可能
- クライアントのローミング履歴を再確認できるビジュアルなインタラクティブローミング再生機能
- 個々のAPおよびクライアントデバイスの詳細なデバイス情報とパフォーマンス指標チャート

1. The Turbo Roaming Recovery Timeは、干渉のない20 MHz RFチャネル、WPA2-PSKセキュリティ、およびデフォルトのTurbo Roamingパラメータで設定されたAPに全体にわたり、最適化された条件で記録されたテスト結果の平均です。クライアントは、100 Kbpsのトラフィック負荷で3チャンネルローミングが設定されています。他の条件もまた、ローミング性能に影響を及ぼす可能性があります。Turbo Roamingパラメータ設定の詳細については、製品マニュアルを参照してください。

## 仕様

### WLAN Interface

WLAN Standards	802.11a/b/g/n 802.11i Wireless Security			
Modulation Type	DSSS OFDM MIMO-OFDM			
Frequency Band for US (20 MHz operating channels)	2.412 to 2.462 GHz (11 channels) 5.180 to 5.240 GHz (4 channels) 5.260 to 5.320 GHz (4 channels) <sup>2</sup> 5.500 to 5.700 GHz (11 channels) <sup>2</sup> 5.745 to 5.825 GHz (5 channels)			
Frequency Band for EU (20 MHz operating channels)	2.412 to 2.472 GHz (13 channels) 5.180 to 5.240 GHz (4 channels) 5.260 to 5.320 GHz (4 channels) <sup>2</sup> 5.500 to 5.700 GHz (11 channels) <sup>2</sup>			
Frequency Band for JP (20 MHz operating channels)	2.412 to 2.484 GHz (14 channels) 5.180 to 5.240 GHz (4 channels) 5.260 to 5.240 GHz (4 channels) <sup>2</sup> 5.500 to 5.700 GHz (11 channels) <sup>2</sup>			
Wireless Security	WEP encryption (64-bit and 128-bit) WPA/WPA2-Enterprise (IEEE 802.1X/RADIUS, TKIP, AES) WPA/WPA2-Personal			
Transmission Rate	802.11b: 1 to 11 Mbps 802.11a/g: 6 to 54 Mbps 802.11n: 6.5 to 300 Mbps			
Transmitter Power for 802.11a	23±1.5 dBm @ 6 to 24 Mbps 21±1.5 dBm @ 36 Mbps 20±1.5 dBm @ 48 Mbps 18±1.5 dBm @ 54 Mbps			
Transmitter Power for 802.11n (5 GHz)	23±1.5 dBm @ MCS0/8 20 MHz 18±1.5 dBm @ MCS7/15 20 MHz 23±1.5 dBm @ MCS0/8 40 MHz 17±1.5 dBm @ MCS7/15 40 MHz			
Transmitter Power for 802.11b	26±1.5 dBm @ 1 Mbps 26±1.5 dBm @ 2 Mbps 26±1.5 dBm @ 5.5 Mbps 25±1.5 dBm @ 11 Mbps			
Transmitter Power for 802.11g	23±1.5 dBm @ 6 to 24 Mbps 21±1.5 dBm @ 36 Mbps 19±1.5 dBm @ 48 Mbps 18±1.5 dBm @ 54 Mbps			
Transmitter Power for 802.11n (2.4 GHz)	23±1.5 dBm @ MCS0/8 20 MHz 18±1.5 dBm @ MCS7/15 20 MHz 23±1.5 dBm @ MCS0/8 40 MHz 17±1.5 dBm @ MCS7/15 40 MHz			
Transmitter Power		US	EU	JP
	2.4 GHz	26 dBm	18 dBm	18 dBm
	5 GHz (UNII-1)	23 dBm	21 dBm	21 dBm
	5 GHz (UNII-2)	23 dBm	21 dBm	21 dBm
	5 GHz (UNII-2e)	23 dBm	23 dBm	23 dBm

2. DFS (Dynamic Frequency Selection) channel support: In AP mode, when a radar signal is detected, the device will automatically switch to another channel.ただし、規定により、チャンネル切り替え後はサービス開始前に 60 秒間の可用性チェック期間が必要となります。

	US	EU	JP
5 GHz (UNII-3)	23 dBm	-	-
Note: Based on regional regulations, the maximum transmission power allowed on the UNII bands is restricted in the firmware, as indicated above.			
Receiver Sensitivity for 802.11a (measured at 5.680 GHz)	Typ. -90 @ 6 Mbps Typ. -88 @ 9 Mbps Typ. -88 @ 12 Mbps Typ. -85 @ 18 Mbps Typ. -81 @ 24 Mbps Typ. -78 @ 36 Mbps Typ. -74 @ 48 Mbps Typ. -72 @ 54 Mbps Note: Due to a limitation in the receiver sensitivity performance for channels 153 and 161, it is recommended to avoid using these channels in your critical applications.		
Receiver Sensitivity for 802.11n (5 GHz; measured at 5.680 GHz)	Typ. -69 dBm @ MCS7 20 MHz Typ. -71 dBm @ MCS15 20 MHz Typ. -63 dBm @ MCS7 40 MHz Typ. -68 dBm @ MCS15 40 MHz Note: Due to a limitation in the receiver sensitivity performance for channels 153 and 161, it is recommended to avoid using these channels in your critical applications.		
Receiver Sensitivity for 802.11b (measured at 2.437 GHz)	Typ. -93 dBm @ 1 Mbps Typ. -93 dBm @ 2 Mbps Typ. -93 dBm @ 5.5 Mbps Typ. -88 dBm @ 11 Mbps		
Receiver Sensitivity for 802.11g (measured at 2.437 GHz)	Typ. -88 dBm @ 6 Mbps Typ. -86 dBm @ 9 Mbps Typ. -85 dBm @ 12 Mbps Typ. -85 dBm @ 18 Mbps Typ. -85 dBm @ 24 Mbps Typ. -82 dBm @ 36 Mbps Typ. -78 dBm @ 48 Mbps Typ. -74 dBm @ 54 Mbps		
Receiver Sensitivity for 802.11n (2.4 GHz; measured at 2.437 GHz)	Typ. -70 dBm @ MCS7 20 MHz Typ. -69 dBm @ MCS15 20 MHz Typ. -67 dBm @ MCS7 40 MHz Typ. -67 dBm @ MCS15 40 MHz		
WLAN Operation Mode	Access point, Client, Client-Router, Master, Slave, Sniffer		
Antenna	External, 3/6 dBi, Omni-directional		
WLAN Antenna Connector	2 N-type female		

## Ethernet Interface

Standards	IEEE 802.3 for 10BaseT IEEE 802.3u for 100BaseT(X) IEEE 802.3ab for 1000BaseT(X) IEEE 802.3at for PoE IEEE 802.1D-2004 for Spanning Tree Protocol IEEE 802.1w for Rapid Spanning Tree Protocol IEEE 802.1Q for VLAN Tagging
PoE Ports (10/100/1000BaseT(X), RJ45 connector)	1

## Ethernet Software Features

Management	DHCP Server/Client, DNS, HTTP, IPv4, LLDP, Proxy ARP, SMTP, SNMPv1/v2c/v3, Syslog, TCP/IP, Telnet, UDP, VLAN, Wireless Search Utility, MXview, MXview Wireless, MXconfig
Routing	Static Route, NAT, Port forwarding
Redundancy Protocols	RSTP, STP

Security	HTTPS/SSL, RADIUS, SSH
Time Management	SNTP Client
<b>Firewall</b>	
Filter	ICMP, MAC address, IP protocol, Port-based
<b>Serial Interface</b>	
Console Port	RS-232, 8-pin RJ45
<b>LED Interface</b>	
LED Indicators	PWR, FAULT, STATE, WLAN, LAN
<b>Input/Output Interface</b>	
Alarm Contact Channels	Relay output with current carrying capacity of 1 A @ 24 VDC
Buttons	Reset button
Digital Inputs	+13 to +30 V for state 1 +3 to -30 V for state 0 Max. input current: 8 mA
<b>Physical Characteristics</b>	
Housing	Metal
IP Rating	IP68
Dimensions	224 x 147.7 x 66.5 mm (8.82 x 5.82 x 2.62 in)
Weight	1,400 g (3.09 lb)
Installation	Wall mounting (standard), DIN-rail mounting (optional), Pole mounting (optional)
<b>Power Parameters</b>	
Input Current	0.64 A @ 12 VDC, 0.16 A @ 48 VDC
Input Voltage	12 to 48 VDC, Redundant dual inputs, 48 VDC Power-over-Ethernet
Power Connector	M12 A-coded 5-pin male connector
Power Consumption	7.68 W (max.)
Reverse Polarity Protection	Supported
<b>Environmental Limits</b>	
Operating Temperature	-40 to 75°C (-40 to 167°F)
Storage Temperature (package included)	-40 to 85°C (-40 to 185°F)
Ambient Relative Humidity	5 to 95% (non-condensing)
<b>Standards and Certifications</b>	
EMC	EN 61000-6-2/-6-4
EMI	CISPR 32, FCC Part 15B Class A
EMS	IEC 61000-4-2 ESD: Contact: 8 kV; Air: 15 kV IEC 61000-4-3 RS: 80 MHz to 1 GHz: 10 V/m IEC 61000-4-4 EFT: Power: 2 kV; Signal: 1 kV IEC 61000-4-5 Surge: Power: 2 kV; Signal: 2 kV IEC 61000-4-6 CS: 10 V IEC 61000-4-8 PFMF

Radio	EN 300 328, EN 301 489-1/17, EN 301 893, FCC ID SLE-WAPN008, ANATEL, MIC, NCC, RCM, SRRRC, WPC, KC
Safety	EN 60950-1, UL 60950-1
Vibration	IEC 60068-2-6

#### MTBF

Time	440,764 hrs
Standards	Telcordia SR332

#### Warranty

Warranty Period	5 years
Details	See <a href="http://www.moxa.com/jp/warranty">www.moxa.com/jp/warranty</a>

#### Package Contents

Device	1 x AWK-4131A Series wireless AP/bridge/client
Installation Kit	1 x cap, female, metal, for M12 port 1 x cap, metal, for RJ45 port 1 x field-installable power plug 1 x field-installable RJ45 plug 1 x stick, transparent plastic, for field-installable plug 2 x wall-mounting kit
Antenna	2 x 2.4/5 GHz antenna
Documentation	1 x quick installation guide 1 x warranty card

## 寸法

単位: mm (インチ)

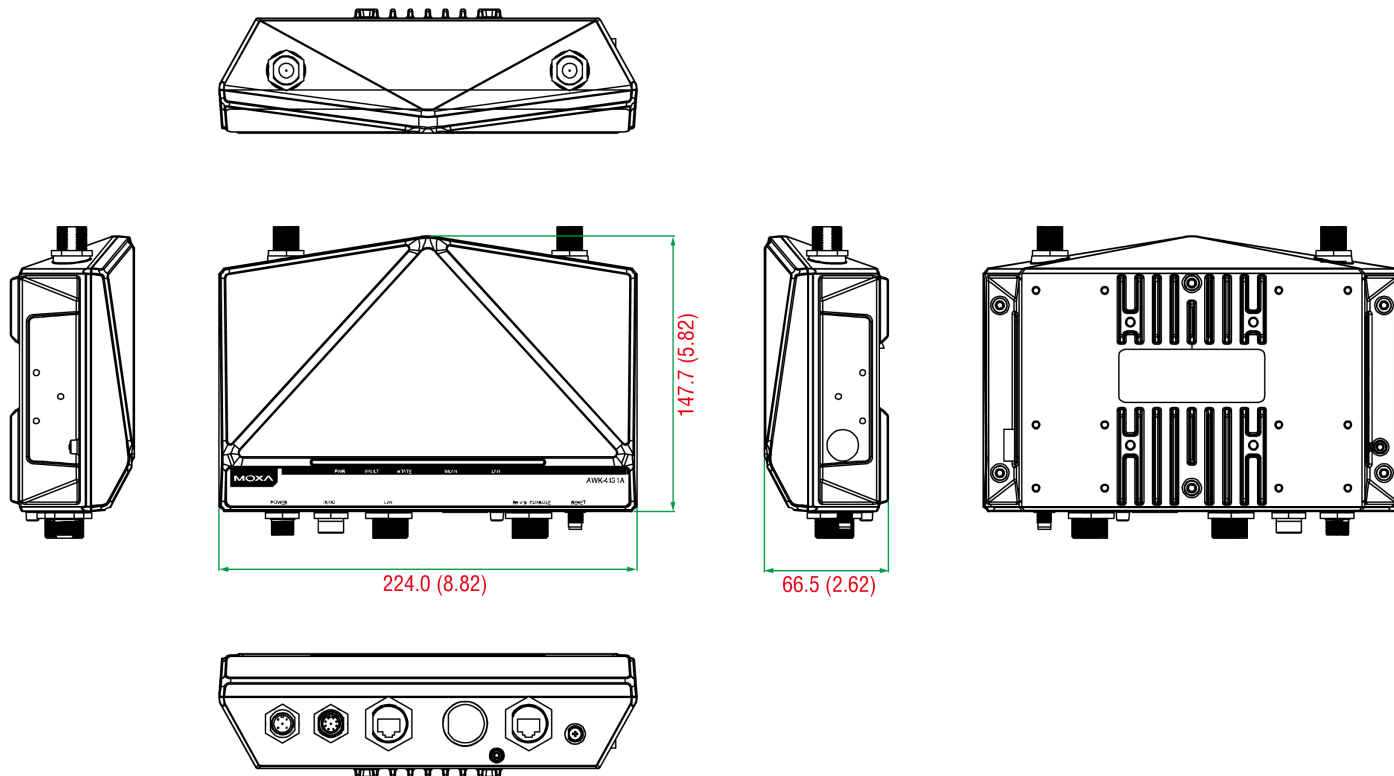

側面図

前面図、上面図と背面図

側面図

底面図

## 注文情報

Model Name	Band	Standards	Operating Temp.
AWK-4131A-EU-T	EU	802.11a/b/g/n	-40 to 75°C
AWK-4131A-JP-T	JP	802.11a/b/g/n	-40 to 75°C
AWK-4131A-US-T	US	802.11a/b/g/n	-40 to 75°C

## アクセサリ (別売)

### Antennas

ANT-WDB-ONF-0709	7 dBi at 2.4 GHz or 9 dBi at 5 GHz, N-type (female), dual-band, omnidirectional antenna
ANT-WDB-ANM-0306	3 dBi at 2.4 GHz or 6 dBi at 5 GHz, N-type (male), omnidirectional antenna
ANT-WDB-ONM-0707	07 dBi at 2.4 GHz and 07 dBi at 5 GHz, N-type (male), dual-band omnidirectional antenna
ANT-WDB-ANM-0502	5 dBi at 2.4 GHz or 2 dBi at 5 GHz, N-type (male), omnidirectional antenna
ANT-WDB-ARM-02	2 dBi at 2.4 GHz or 2 dBi at 5 GHz, RP-SMA (male) omnidirectional rubber-duck antenna
ANT-WDB-ARM-0202	2 dBi at 2.4 GHz or 2 dBi at 5 GHz, RP-SMA (male), dual-band, omnidirectional antenna
ANT-WDB-PNF-1011	10 dBi at 2.4 GHz and 11 dBi at 5 GHz, N-type (female), dual-band directional antenna
MAT-WDB-CA-RM-2-0205	2.4/5 GHz, ceiling antenna, 2/5 dBi, MIMO 2x2, RP-SMA-type (male)
MAT-WDB-DA-RM-2-0203-1m	2.4/5 GHz, desktop antenna, 2/3 dBi, MIMO 2x2, RP-SMA-type (male), 1 m cable
MAT-WDB-PA-NF-2-0708	2.4/5 GHz, panel antenna, 7/8 dBi, MIMO 2x2, N-type (female)
ANT-WSB5-PNF-16	16 dBi at 5 GHz, N-type (female), single-band directional antenna
ANT-WSB-PNF-12-02	12 dBi at 2.4 GHz, N-type (female), single-band directional antenna

ANT-WSB-AHRM-05-1.5m	5 dBi at 2.4 GHz, RP-SMA (male), omnidirectional/dipole antenna, 1.5 m cable
----------------------	--

### Wireless Antenna Cables

A-CRF-NMNM-LL4-300	N-type (male) to N-type (male) LMR-400 Lite cable, 3 m
A-CRF-NMNM-LL4-600	N-type (male) to N-type (male) LMR-400 Lite cable, 6 m
A-CRF-NMNM-LL4-900	N-type (male) to N-type (male) LMR-400 Lite cable, 9 m

### Wireless AP Connector Cables

M12A-8PFF-IP68	Field-installation A-coded M12 screw-in 8-pin connector, female connector female PIN
M12A-8PMM-IP68	Field-installation A-coded screw-in Gigabit Ethernet connector, 8-pin male M12 connector, IP68-rated
A-PLG-WPRJ	Field-installation RJ-type plug

### Wireless Connector Caps

A-CAP-N-M	A-CAP-N-M
A-CAP-WPRJ45-MC	Metal cap with chain for RJ45 connector

### Surge Arrestors

A-SA-NFNF-02	0 to 6 GHz, N-type (female) to N-type (female) surge arrester
A-SA-NMNF-02	0 to 6 GHz, N-type (male) to N-type (female) surge arrester

### Wireless Adapters

A-ADP-RJ458P-DB9F-ABC01	DB9 female to RJ45 connector for the ABC-01 Series
-------------------------	--

### Wireless Terminating Resistors

A-TRM-50-NM	50-ohm termination resistor with N-type male connector
-------------	--

### Wall-Mounting Kits

WK-51-01	Wall mounting kit with 2 plates (51.6 x 67 x 2 mm) and 6 screws
----------	---

### Wireless AP Mounting Kits

WK-55	Wall mounting kit with 2 plates (55 x 34.5 x 2.5 mm) and 6 screws
-------	---

© Moxa Inc. All rights reserved. 2022年8月17日更新。

Moxa Inc.の明白な許可を書面で取得しない限り、本書およびその一部の複製や使用はいかなる方法やいかなる場合でも許可されません。製品の仕様は予告なく変更されることがあります。最新の製品情報については当社のWebサイトをご覧ください。