

# SDS-G3016 Series

## 16G-port full Gigabit smart Ethernet switches



### Features and Benefits

- Compact and flexible housing design to fit into confined spaces
- Web-based GUI for easy device configuration and management
- Multi-language web GUI: English, Traditional Chinese, Simplified Chinese, Japanese, German, and French
- Supports RSTP/STP, and MRP for network redundancy to ensure high network availability
- EtherNet/IP, PROFINET, and Modbus TCP industrial protocols supported for easy integration and monitoring in automation HMI/SCADA systems
- Rotary DIP switch can perform profile-based settings without using a web browser
- Supports MXstudio for easy, visualized industrial network management

### Certifications



## Introduction

The SDS-G3016 smart Ethernet switch is the ideal product for IA engineers and automation machine builders to make their networks compatible with the vision of Industry 4.0. By breathing life into machines and control cabinets, the smart switch simplifies daily tasks with its easy configuration and easy installation. In addition, it is monitorable and is easy to maintain throughout the entire product life cycle.

The most frequently used automation protocols—including EtherNet/IP, PROFINET, and Modbus TCP—are embedded in the SDS-G3016 switch to provide enhanced operational performance and flexibility by making it controllable and visible from automation HMIs. It also supports a range of useful management functions, including IEEE 802.1Q VLAN, port mirroring, SNMP, warning by relay, and a multi-language Web GUI.

### Additional Features and Benefits

- IP port binding to ensure critical devices can be replaced quickly without reassigning the IP Address
- IEEE 802.1Q VLAN to ease network planning
- Supports the ABC-02-USB (automatic Backup Configurator) for quick system configuration backup/restore and firmware upgrade
- Automatic warning by exception through relay output
- Unused port lock, SNMPv3, and HTTPS to enhance network security
- Port mirroring for online debugging and monitoring
- Local log and the ability to export inventory files ease inventory management

## Specifications

### Ethernet Interface

10/100/1000BaseT(X) Ports (RJ45 connector)	SDS-G3016(-T) models: 16 SDS-G3016-2GSFP(-T) models: 14 Auto negotiation speed Full/Half duplex mode Auto MDI/MDI-X connection
100/1000BaseSFP Slots	SDS-G3016-2GSFP(-T) models: 2
Standards	IEEE 802.3 for 10BaseT IEEE 802.3u for 100BaseT(X) IEEE 802.3ab for 1000BaseT(X) IEEE 802.3x for flow control IEEE 802.1D-2004 for Spanning Tree Protocol IEEE 802.1w for Rapid Spanning Tree Protocol IEEE 802.1Q for VLAN Tagging IEEE 802.1p for Class of Service

## Ethernet Software Features

Industrial Protocols	EtherNet/IP Modbus TCP PROFINET IO Device MECHATROLINK-4
Management	Back Pressure Flow Control DHCP Client Fiber check Flow control IPv4/IPv6 LLDP Port Mirroring RMON SNMP Inform SNMPv1/v2c/v3 Syslog
MIB	RFC1213 Ethernet-like-MIB IF-MIB LLDP-MIB Bridge-MIB Q-BRIDGE-MIB
Redundancy Protocols	RSTP STP MRP
Security	Broadcast storm protection HTTPS/SSL SNMPv3 Port Lock Trust access control
Time Management	NTP Server/Client SNTP
Filter	802.1Q VLAN

## Rotary Switch Configuration

Industrial Profile	Indicator	Mode
	0	No function enabled via DIP switch (Default)
	1	PROFINET profile enabled
	2	PROFINET profile and DHCP client enabled
	3	EtherNet/IP profile enabled
	4	EtherNet/IP profile and DHCP client enabled
	5	Modbus TCP profile enabled
	6	Modbus TCP profile and DHCP client enabled
	7	MECHATROLINK-4 profile enabled
	8-9	Reserved (currently performs the same behavior as indicator 0)

## Switch Properties

Jumbo Frame Size	9.6 KB
MAC Table Size	8 K
Max. No. of VLANs	8

VLAN ID Range	VID 1 to 4094
Packet Buffer Size	3 Mbits
<b>LED Interface</b>	
LED Indicators	PWR1, PWR2, STATE, FAULT, 10/100M (TP Port), 1000M (TP port), 100/1000M (SFP port)
<b>USB Interface</b>	
Storage Port	USB Type A (for ABC-02 only)
<b>Input/Output Interface</b>	
Alarm Contact Channels	1 Relay output with current carrying capacity of 1 A @ 24 VDC
Buttons	Reset button
Digital Input Channels	1
Digital Inputs	+13 to +30 V for state 1 -30 to +3 V for state 0 Max. input current: 8 mA
<b>Power Parameters</b>	
Connection	2 removable 4-contact terminal block(s)
Input Voltage	12-48 VDC Redundant dual inputs
Operating Voltage	9.6 to 60 VDC
Input Current	SDS-G3016(-T) models: 1.08 A max. SDS-G3016-2GSFP(-T) models: 1.29 A max.
Power Consumption	SDS-G3016(-T) models: 12.95 W max. SDS-G3016-2GSFP(-T) models: 15.49 W max.
Overload Current Protection	Supported
Reverse Polarity Protection	Supported
<b>Physical Characteristics</b>	
Housing	Metal
IP Rating	IP40
Dimensions	36 x 135 x 111 mm (1.42 x 5.32 x 4.37 in)
Weight	SDS-G3016(-T) models: 772g (1.70 lbs) SDS-G3016-2GSFP(-T) models: 796g (1.75 lbs)
Installation	DIN-rail mounting Wall mounting (with optional kit)
<b>Environmental Limits</b>	
Operating Temperature	Standard Models: -10 to 60°C (14 to 140°F) Wide Temp. Models: -40 to 75°C (-40 to 167°F) -10 to 60°C (14 to 140°F) -40 to 75°C (-40 to 167°F) -10 to 60°C (14 to 140°F)
Storage Temperature (package included)	-40 to 85°C (-40 to 185°F)
Ambient Relative Humidity	5 to 95% (non-condensing)

## Standards and Certifications

EMC	EN 55032/35 EN 61000-6-2/-6-4
EMI	CISPR 32, FCC Part 15B Class A
EMS	IEC 61000-4-2 ESD: Contact: 6 kV; Air: 8 kV IEC 61000-4-3 RS: 80 MHz to 800 MHz: 10 V/m; 800 MHz to 1 GHz: 20 V/m IEC 61000-4-4 EFT: Power: 2 kV; Signal: 2 kV IEC 61000-4-5 Surge: Power: 2 kV; Signal: 2 kV (1.2/50 $\mu$ s), 1 kV (10/700 $\mu$ s) IEC 61000-4-6 CS: 10 V IEC 61000-4-8 PFMF
Safety	EN IEC 62368-1 UL 61010-2-201
Shock	IEC 60068-2-27
Vibration	IEC 60068-2-6
Package Drop Test	ISTA 1A
Package Vibration Test	ISTA 1A

## MTBF

Time	SDS-G3016(-T) models: 2,982,863 hrs SDS-G3016-2GSFP(-T) models: 2,844,904 hrs
Standards	Telcordia (Bellcore), GB

## Warranty

Warranty Period	5 years
Details	See <a href="http://www.moxa.com/warranty">www.moxa.com/warranty</a>

## Package Contents

Device	1 x SDS-G3016 Series switch
Documentation	1 x product certificates of quality inspection, Simplified Chinese 1 x product notice, Simplified Chinese 1 x quick installation guide 1 x warranty card

## Dimensions

### SDS-G3016 Models

Unit: mm (inch)

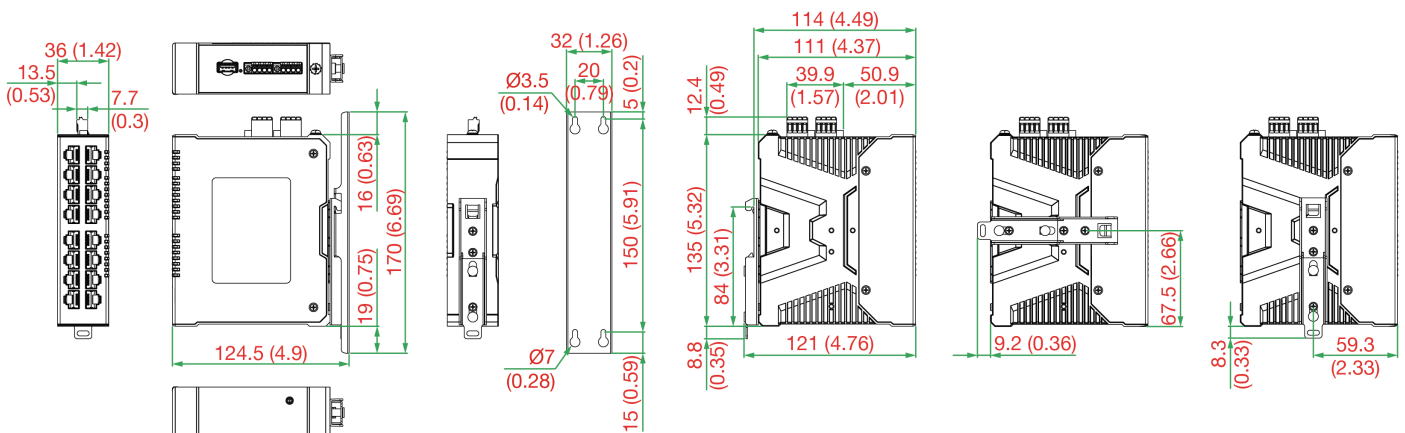

## SDS-G3016 2GSFP Models

Unit: mm (inch)

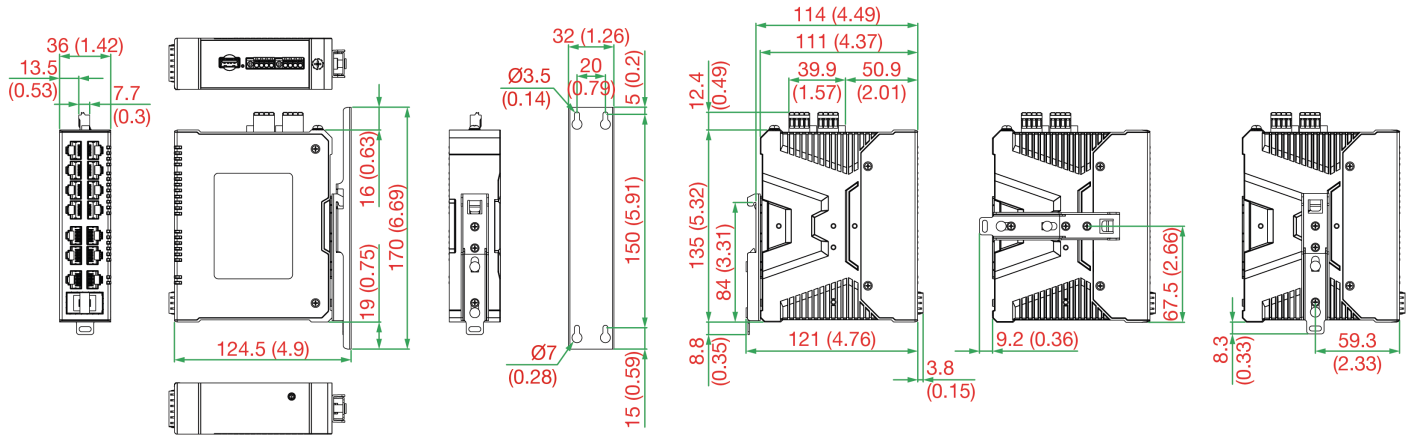

## Ordering Information

Model Name	10/100/1000BaseT(X) Ports, RJ45 Connector	100/1000BaseSFP Ports	Operating Voltage	Operating Temp.
SDS-G3016	16	-	9.6 to 60 VDC	-10 to 60°C
SDS-G3016-T	16	-	9.6 to 60 VDC	-40 to 75°C
SDS-G3016-2GSFP	14	2	9.6 to 60 VDC	-10 to 60°C
SDS-G3016-2GSFP-T	14	2	9.6 to 60 VDC	-40 to 75°C

## Accessories (sold separately)

### Storage Kits

ABC-02-USB	Configuration backup and restoration tool, firmware upgrade, and log file storage tool for managed Ethernet switches and routers, 0 to 60°C operating temperature
ABC-02-USB-T	Configuration backup and restoration tool, firmware upgrade, and log file storage tool for managed Ethernet switches and routers, -40 to 75°C operating temperature

### SFP Modules

SFP-1GEZXC	SFP module with 1 1000BaseEZXC port with LC connector for 110 km transmission, 0 to 60°C operating temperature
SFP-1GEZXC-120	SFP module with 1 1000BaseEZXC port with LC connector for 120 km transmission, 0 to 60°C operating temperature
SFP-1GLHLC	SFP module with 1 1000BaseLH port with LC connector for 30 km transmission, 0 to 60°C operating temperature
SFP-1GLHXC	SFP module with 1 1000BaseLHX port with LC connector for 40 km transmission, 0 to 60°C operating temperature
SFP-1GLSXC	SFP module with 1 1000BaseLSXC port with LC connector for 1km/2km transmission, 0 to 60°C operating temperature
SFP-1GLXC	SFP module with 1 1000BaseLX port with LC connector for 10 km transmission, 0 to 60°C operating temperature
SFP-1GSXC	SFP module with 1 1000BaseSX port with LC connector for 300m/550m transmission, 0 to 60°C operating temperature
SFP-1GZXC	SFP module with 1 1000BaseZXC port with LC connector for 80 km transmission, 0 to 60°C operating temperature
SFP-1GLHLC-T	SFP module with 1 1000BaseLH port with LC connector for 30 km transmission, -40 to 85°C operating temperature
SFP-1GLHXC-T	SFP module with 1 1000BaseLHX port with LC connector for 40 km transmission, -40 to 85°C operating temperature

SFP-1GLSXLC-T	SFP module with 1 1000BaseLSX port with LC connector for 1km/2km transmission, -40 to 85°C operating temperature
SFP-1GLXLC-T	SFP module with 1 1000BaseLX port with LC connector for 10 km transmission, -40 to 85°C operating temperature
SFP-1GSXLC-T	SFP module with 1 1000BaseSX port with LC connector for 300m/550m transmission, -40 to 85°C operating temperature
SFP-1GZXLC-T	SFP module with 1 1000BaseZX port with LC connector for 80 km transmission, -40 to 85°C operating temperature
SFP-1G10ALC	WDM-type (BiDi) SFP module with 1 1000BaseSFP port with LC connector for 10 km transmission; TX 1310 nm, RX 1550 nm, 0 to 60°C operating temperature
SFP-1G10BLC	WDM-type (BiDi) SFP module with 1 1000BaseSFP port with LC connector for 10 km transmission; TX 1550 nm, RX 1310 nm, 0 to 60°C operating temperature
SFP-1G20ALC	WDM-type (BiDi) SFP module with 1 1000BaseSFP port with LC connector for 20 km transmission; TX 1310 nm, RX 1550 nm, 0 to 60°C operating temperature
SFP-1G20BLC	WDM-type (BiDi) SFP module with 1 1000BaseSFP port with LC connector for 20 km transmission; TX 1550 nm, RX 1310 nm, 0 to 60°C operating temperature
SFP-1G40ALC	WDM-type (BiDi) SFP module with 1 1000BaseSFP port with LC connector for 40 km transmission; TX 1310 nm, RX 1550 nm, 0 to 60°C operating temperature
SFP-1G40BLC	WDM-type (BiDi) SFP module with 1 1000BaseSFP port with LC connector for 40 km transmission; TX 1550 nm, RX 1310 nm, 0 to 60°C operating temperature
SFP-1G10ALC-T	WDM-type (BiDi) SFP module with 1 1000BaseSFP port with LC connector for 10 km transmission; TX 1310 nm, RX 1550 nm, -40 to 85°C operating temperature
SFP-1G10BLC-T	WDM-type (BiDi) SFP module with 1 1000BaseSFP port with LC connector for 10 km transmission; TX 1550 nm, RX 1310 nm, -40 to 85°C operating temperature
SFP-1G20ALC-T	WDM-type (BiDi) SFP module with 1 1000BaseSFP port with LC connector for 20 km transmission; TX 1310 nm, RX 1550 nm, -40 to 85°C operating temperature
SFP-1G20BLC-T	WDM-type (BiDi) SFP module with 1 1000BaseSFP port with LC connector for 20 km transmission; TX 1550 nm, RX 1310 nm, -40 to 85°C operating temperature
SFP-1G40ALC-T	WDM-type (BiDi) SFP module with 1 1000BaseSFP port with LC connector for 40 km transmission; TX 1310 nm, RX 1550 nm, -40 to 85°C operating temperature
SFP-1G40BLC-T	WDM-type (BiDi) SFP module with 1 1000BaseSFP port with LC connector for 40 km transmission; TX 1550 nm, RX 1310 nm, -40 to 85°C operating temperature
SFP-1FELLC-T	SFP module with 1 100Base single-mode with LC connector for 80 km transmission, -40 to 85°C operating temperature
SFP-1FEMLC-T	SFP module with 1 100Base multi-mode, LC connector for 2/4 km transmission, -40 to 85°C operating temperature
SFP-1FESLC-T	SFP module with 1 100Base single-mode with LC connector for 40 km transmission, -40 to 85°C operating temperature
SFP-1GTXRJ45-T	SFP module with 1 1000BaseT port with RJ45 connector for 100 m transmission, -40 to 75°C operating temperature

#### Power Supplies

MDR-40-24	DIN-rail 24 VDC power supply with 40W/1.7A, 85 to 264 VAC, or 120 to 370 VDC input, -20 to 70°C operating temperature
MDR-60-24	DIN-rail 24 VDC power supply with 60W/2.5A, 85 to 264 VAC, or 120 to 370 VDC input, -20 to 70°C operating temperature

© Moxa Inc. All rights reserved. Updated Apr 08, 2026.

This document and any portion thereof may not be reproduced or used in any manner whatsoever without the express written permission of Moxa Inc. Product specifications subject to change without notice. Visit our website for the most up-to-date product information.