

# V2400 Series Expansion Modules User Manual

---

Fifth Edition, November 2012

[www.moxa.com/product](http://www.moxa.com/product)

**MOXA**<sup>®</sup>

© 2012 Moxa Inc. All rights reserved.

# V2400 Series Expansion Modules User Manual

The software described in this manual is furnished under a license agreement and may be used only in accordance with the terms of that agreement.

## Copyright Notice

© 2012 Moxa Inc., All rights reserved.

## Trademarks

The MOXA logo is a registered trademark of Moxa Inc.  
All other trademarks or registered marks in this manual belong to their respective manufacturers.

## Disclaimer

Information in this document is subject to change without notice and does not represent a commitment on the part of Moxa.

Moxa provides this document as is, without warranty of any kind, either expressed or implied, including, but not limited to, its particular purpose. Moxa reserves the right to make improvements and/or changes to this manual, or to the products and/or the programs described in this manual, at any time.

Information provided in this manual is intended to be accurate and reliable. However, Moxa assumes no responsibility for its use, or for any infringements on the rights of third parties that may result from its use.

This product might include unintentional technical or typographical errors. Changes are periodically made to the information herein to correct such errors, and these changes are incorporated into new editions of the publication.

## Technical Support Contact Information

[www.moxa.com/support](http://www.moxa.com/support)

### **Moxa Americas**

Toll-free: 1-888-669-2872

Tel: +1-714-528-6777

Fax: +1-714-528-6778

### **Moxa Europe**

Tel: +49-89-3 70 03 99-0

Fax: +49-89-3 70 03 99-99

### **Moxa China (Shanghai office)**

Toll-free: 800-820-5036

Tel: +86-21-5258-9955

Fax: +86-21-5258-5505

### **Moxa Asia-Pacific**

Tel: +886-2-8919-1230

Fax: +886-2-8919-1231

# Table of Contents

|  |            |
|--|------------|
| <b>1. Introduction</b>   | <b>1-1</b> |
| Overview   | 1-2        |
| Package Checklist  | 1-2        |
| Available Modules  | 1-2        |
| EPM-3338 Optional Accessories  | 1-2        |
| EPM Module Specifications  | 1-2        |
| EPM-3032 Specifications  | 1-2        |
| EPM-3112 Specifications  | 1-3        |
| EPM-3337 Specifications  | 1-3        |
| EPM-3438 Specifications  | 1-5        |
| EPM-3552 Specifications  | 1-5        |
| EPM-DK01 Specifications  | 1-5        |
| EPM-DK02 Specifications  | 1-6        |
| EPM-DK03 Specifications  | 1-6        |
| EPM-3338 Specifications  | 1-7        |
| <b>2. Hardware Introduction</b>  | <b>2-1</b> |
| Appearance   | 2-2        |
| EPM-3032   | 2-2        |
| EPM-3112   | 2-2        |
| EPM-3337   | 2-2        |
| EPM-3438   | 2-2        |
| EPM-3552   | 2-3        |
| EPM-DK01   | 2-3        |
| EPM-DK02   | 2-4        |
| EPM-3338   | 2-4        |
| EPM-DK03   | 2-5        |
| Dimensions   | 2-6        |
| <b>3. Hardware Connection Description</b>                                | <b>3-1</b> |
| Installing the EPM Expansion Modules                                     | 3-2        |
| Connecting Data Transmission Cables                                      | 3-2        |
| EPM-3032 Serial Port Module  | 3-2        |
| EPM-3337 Wireless/GPS Module   | 3-3        |
| EPM-3438 DI/DO Module  | 3-3        |
| EPM-3112 CAN Bus Module  | 3-4        |
| EPM-DK01 Module: mini PCI + mini PCIe Sockets                            | 3-4        |
| EPM-3552 Display Module  | 3-4        |
| EPM-DK02 Module: 2 mini PCIe Sockets                                     | 3-6        |
| Installing Cellular/Wi-Fi Modules on the EPM-DK02, EPM-DK03, or EPM-3338 | 3-6        |
| Configuring Power Controls on Socket 1                                   | 3-6        |
| Installing a Cellular Module   | 3-7        |
| Arranging Cables on the Wi-Fi or Cellular Modules                        | 3-10       |
| <b>4. Software Installation and Programming Guide</b>                    | <b>4-1</b> |
| Linux System Peripherals Programming Guide                               | 4-2        |
| EPM-3032: Driver Installation  | 4-2        |
| EPM-3032: Configuring Baud Rate  | 4-2        |
| EPM-3032: Configuring Serial Port Modes                                  | 4-3        |
| EPM-3438: Driver Installation  | 4-5        |
| EPM-3438: Programming Digital I/O or the Counter                         | 4-6        |
| Implementing Timer Functions on Digital IO Ports                         | 4-9        |
| EPM-3337 Driver Installation   | 4-15       |
| EPM-3337: Operating Modes  | 4-16       |
| EPM-3337: Setting up a Wi-Fi Connection                                  | 4-21       |
| EPM-3337: Getting Wireless Card Information                              | 4-23       |
| EPM-3112: CAN Bus Interface  | 4-23       |
| EPM-3112: Driver Installation  | 4-23       |
| EPM-3112: Programming Guide  | 4-24       |
| EPM-3552: Driver Installation  | 4-26       |
| EPM-3552: Configuring the X Server                                       | 4-26       |
| EPM-3552: Enabling a Dual Screen Display                                 | 4-27       |
| EPM-3552: Configuring a Single Display                                   | 4-28       |
| EPM-3552: Dynamically Changing the Display Resolution                    | 4-28       |
| EPM-DK02: Driver Installation  | 4-29       |
| EPM-DK02: Installing the Kernel Module                                   | 4-29       |
| EPM-DK02: Configuring Power Controls                                     | 4-29       |
| EPM-DK03: Driver Installation  | 4-31       |
| EPM-DK03: Installing the GPS Test Clients                                | 4-31       |
| EPM-3338: Driver Installation  | 4-32       |

|   |            |
|---|------------|
| EPM-3338: Wi-Fi Module .....                                    | 4-32       |
| EPM-3338: Cellular Module .....                                 | 4-33       |
| EPM-3338: GPS Module.....                                       | 4-34       |
| Windows System .....  | 4-36       |
| EPM-3032: Driver Installation.....                              | 4-36       |
| EPM-3032: Configuring Serial Port Mode .....                    | 4-38       |
| EPM-3032: Changing the Software-Selectable UART Mode.....       | 4-40       |
| EPM-3438: Driver Installation.....                              | 4-41       |
| EPM-3438: Programming Guide .....                               | 4-43       |
| EPM-3337: Driver Installation.....                              | 4-44       |
| EPM-3338: Wireless Module Driver Installation.....              | 4-48       |
| EPM-3338: Configuring a GPRS/HSDPA Connection (no GPS).....     | 4-50       |
| EPM-3338: Configuring GPS.....                                  | 4-53       |
| EPM-3338: Configuring a Wi-Fi/802.11 Connection .....           | 4-54       |
| EPM-3112: Driver Installation.....                              | 4-57       |
| EPM-3112: Programming Guide .....                               | 4-58       |
| EPM-3552: Driver Installation.....                              | 4-60       |
| EPM-3552: Patch File Installation .....                         | 4-62       |
| EPM-3552: Display Configuration .....                           | 4-63       |
| EPM-3552: Configuring Extended Dual Displays .....              | 4-64       |
| EPM-DK02: Driver Installation .....                             | 4-66       |
| EPM-DK02: Controlling Power .....                               | 4-68       |
| EPM-DK03: Driver Installation .....                             | 4-69       |
| EPM-DK03: GPS Driver Installation .....                         | 4-69       |
| EPM-DK03: Cellular Driver Installation .....                    | 4-73       |
| EPM-DK03: Wi-Fi Driver Installation .....                       | 4-74       |
| EPM-DK03: Configuring the Cellular Software Interface.....      | 4-76       |
| EPM-DK03: Configuring a Wi-Fi Software Interface .....          | 4-78       |
| EPM-DK03: Getting Wi-Fi Information .....                       | 4-80       |
| <b>A. Video Performance Table for the EPM-3552 Module .....</b> | <b>A-1</b> |
| EPM-3552 Display Module Performance on Linux Systems.....       | A-2        |
| EPM-3552 Display Module Performance on Windows Systems.....     | A-3        |

## Introduction

---

Moxa's EPM series modules, which include modules with serial ports, a wireless/GPS card, a digital input/output channel card, a CAN bus card, a mini PCI/PCIe card, a VGA/DVI-I display card, and a 2-slot mini PCIe card, work with Moxa's V2422 and V2426 embedded computers, giving end-users the ability to set up and expand a variety of industrial applications.

The following topics are covered in this chapter:

- **Overview**
- **Package Checklist**
- **Available Modules**
  - EPM-3338 Optional Accessories
- **EPM Module Specifications**
  - EPM-3032 Specifications
  - EPM-3112 Specifications
  - EPM-3337 Specifications
  - EPM-3438 Specifications
  - EPM-3552 Specifications
  - EPM-DK01 Specifications
  - EPM-DK02 Specifications
  - EPM-DK03 Specifications
  - EPM-3338 Specifications

# Overview

Moxa's EPM series modules provide expansion options for V2422 and V2426 embedded computers. Modules may provide serial ports, combined Wi-Fi/GPS, a digital I/O channels, CAN bus interface, mini PCI/PCIe interfaces, combined VGA/DVI-I display, and a 2-slot mini PCIe card, giving end-users the ability to set up V2400 computers for a wide variety of industrial applications.

## Package Checklist

Each package ships with a single EPM expansion module and a quick installation guide

**NOTE: Please notify your sales representative if the module is damaged en route.**

## Available Modules

- EPM-3032: 2 isolated RS-232/422/485 ports, DB9 connectors
- EPM-3112: 2 isolated CAN ports with DB9 connectors
- EPM-3337: HSDPA, GPS, Wi-Fi (11a/b/g/n)
- EPM-3338: GPS, HSPA, Wi-Fi (802.11a/b/g/n)
- EPM-3438: 8+8 DI/DO, with 3 KV digital isolation protection, 2 KHz counter
- EPM-3552: VGA or DVI-I display module
- EPM-DK02: 2-slot Mini PCIe expansion module
- EPM-DK03: GPS + 2-slot Mini PCIe expansion module

## EPM-3338 Optional Accessories

### Wi-Fi Module

- Sparklan WPEA-121N 802.11 a/b/g/n Wi-Fi module
- WPEA-121N extender
- Antenna jack with RF cable (x2)

### Cellular (HSPA) Module

- Sierra Wireless MC8305 HSPA card
- Thermal pad
- Antenna jack with cable

## EPM Module Specifications

### EPM-3032 Specifications

#### Serial Interface

**Serial Standards:** 2 RS-232/422/485 ports, software-selectable (DB9 male)

**Isolation:** 2 KV digital isolation

#### Serial Communication Parameters

**Data Bits:** 5, 6, 7, 8

**Stop Bits:** 1, 1.5, 2

**Parity:** None, Even, Odd, Space, Mark

**Flow Control:** RTS/CTS, XON/XOFF, ADDC® (automatic data direction control) for RS-485

**Baudrate:** 50 bps to 921.6 Kbps (non-standard baudrates supported; see user's manual for details)

#### Serial Signals

**RS-232:** TxD, RxD, DTR, DSR, RTS, CTS, DCD, GND

**RS-422:** TxD+, TxD-, RxD+, RxD-, GND

**RS-485-4w:** TxD+, TxD-, RxD+, RxD-, GND

**RS-485-2w:** Data+, Data-, GND

### Physical Characteristics

**Weight:** 137 g

**Dimensions:** 104 x 121 x 34 mm (4.09 x 4.76 x 1.34 in)

### Environmental Limits

**Operating Temperature:** -40 to 70°C (-40 to 158°F)

## EPM-3112 Specifications

### CAN bus Communication

**Interface:** 2 optically isolated CAN2.0A/2.0B compliant ports

**CAN Controller:** Phillips SJA1000T

**Signals:** CAN-H, CAN-L

**Isolation:** 2 KV digital isolation

**Speed:** 1 Mbps

**Connector Type:** DB9 male

### Physical Characteristics

**Weight:** 127 g

**Dimensions:** 104 x 121 x 34 mm (4.09 x 4.76 x 1.34 in)

### Environmental Limits

**Operating Temperature:** -25 to 55°C (-13 to 131°F)

## EPM-3337 Specifications

### Cellular Interface

#### Frequency Bands:

- UMTS/HSDPA: Triple band, 850/1900/1900 MHz
- GSM/GPRS/EDGE: Quad band, 850/900/1800/2100 MHz
- GSM DASS: Small MS

#### Output Power:

- Class 4 (2 W) for GSM850/900
- Class 3 (0.25 W) for UMTS/HSDPA
- Class E2 (0.5 W) for EDGE850/900
- Class E2 (0.4 W) for EDGE1800/1900
- Class 1 (1 W) for GSM1800/1900

### HSDPA Interface

#### 3GPP Release 5:

- 3.6 Mbps, UL 384 Kbps
- UE CAT. [1-6], 11, 12 supported
- Compressed mode (CM) supported according to 3GPP TS25.212

### GPS Interface

**Tracking:** Tracks up to 13 satellites, L1 1575.42 MHz

**Accuracy Position:** 2.5 m CEP; 5.0 m SEP

**Protocols:** NMEA-0183 V2.3, E911 AGPS Control plane, GPS dedicated AT commands, Date WGS-84

**Tracking sensitivity:** -158 dBm (with active antenna)

#### Start-up Time:

- Hot start: <3s
- Cold start: 30s
- Warm start: 30s

**GPS active antenna supply:** 3.3 V

## WLAN Interface

### Supported Modes:

- IEEE 802.11a/b/g/n for client/bridge mode
- IEEE 802.11b/g/n for AP mode (Linux OS only)

### Standards:

- IEEE 802.11a/b/g/n for Wireless LAN
- IEEE 802.11i for Wireless Security

### Operating Channels (central frequency):

- US: 2.412 to 2.462 GHz (11 channels), 5.18 to 5.24 GHz (4 channels)
- EU: 2.412 to 2.472 GHz (13 channels), 5.18 to 5.24 GHz (4 channels)
- USA: 1 to 11 (2400 to 2483.5 MHz)
- Europe: 1 to 13 (2400 to 2483.5 MHz)
- Japan: 1 to 14 (2400 to 2497 MHz)

#### 802.11g:

- USA: 1 to 11 (2400 to 2483.5 MHz)
- Europe: 1 to 13 (2400 to 2483.5 MHz)
- Japan: 1 to 13 (2400 to 2497 MHz)

#### 802.11a:

- USA: 36 to 165 (5180 to 5825 MHz)
- Europe: 36 140 (5180 to 5700 MHz)
- Japan: 7 to 11 (5035 to 5055MHz),183 to 189 (4915 to 4945 MHz)

**Security:** 64-bit and 128-bit WEP encryption, WPA /WPA2-Personal and Enterprise (IEEE 802.1X/RADIUS, TKIP and AES)

### Transmission Rates:

- 802.11b: 1, 2, 5.5, 11 Mbps
- 802.11a/g: 6, 9, 12, 18, 24, 36, 48, 54 Mbps
- 802.11n: 6 to 300 Mbps (multiple rates supported)

### TX Transmit Power:

- 802.11b: 1 to 11 Mbps: Typ. 18 dBm ( $\pm 1.5$  dBm)
- 802.11g: 6 to 24 Mbps: Typ. 18 dBm ( $\pm 1.5$  dBm); 36 to 48 Mbps: Typ. 17 dBm ( $\pm 1.5$  dBm); 54 Mbps: Typ. 15 dBm ( $\pm 1.5$  dBm)
- 802.11a: 6 to 24 Mbps: Typ. 17 dBm ( $\pm 1.5$  dBm) 36 to 48 Mbps: Typ. 16 dBm ( $\pm 1.5$  dBm); 54 Mbps: Typ. 14 dBm ( $\pm 1.5$  dBm)

### TX Transmit Power MIMO:

- 802.11a/n (20/40 MHz): MCS15 20 MHz: Typ. 13 dBm ( $\pm 1.5$  dBm); MCS15 40 MHz: Typ. 12 dBm ( $\pm 1.5$  dBm)
- 802.11g/n (20/40 MHz): MCS15 20 MHz: Typ. 14 dBm ( $\pm 1.5$  dBm); MCS15 40 MHz: Typ. 13 dBm ( $\pm 1.5$  dBm)

### RX Sensitivity:

- 802.11b:
  - 92 dBm @ 1 Mbps, -90 dBm @ 2 Mbps, -88 dBm @ 5.5 Mbps, -84 dBm @ 11 Mbps
- 802.11g:
  - 87 dBm @ 6 Mbps, -86 dBm @ 9 Mbps, -85 dBm @ 12 Mbps, -82 dBm @ 18 Mbps, -80 dBm @ 24 Mbps, -76 dBm @ 36 Mbps, -72 dBm @ 48 Mbps, -70 dBm @ 54 Mbps
- 802.11a:
  - 87 dBm @ 6 Mbps, -86 dBm @ 9 Mbps, -85 dBm @ 12 Mbps, -82 dBm @ 18 Mbps, -80 dBm @ 24 Mbps, -76 dBm @ 36 Mbps, -72 dBm @ 48 Mbps, -70 dBm @ 54 Mbps

### RX Sensitivity MIMO:

- 802.11a/n:
  - 68 dBm @ MCS15 40 MHz, -70 dBm @ MCS7 40 MHz, -69 dBm @ MCS15 20 MHz, -71 dBm @ MCS7 20 MHz
- 802.11g/n:
  - 68 dBm @ MCS15 40 MHz, -70 dBm @ MCS7 40 MHz, -69 dBm @ MCS15 20 MHz, -71 dBm @ MCS7 20 MHz



**AP-only Protocols:** ARP, BOOTP, DHCP, dynamic VLAN-Tags for 802.1X-Clients, STP/RSTP (IEEE 802.1D/w)

**Default Antenna:** 2 dBi dual-band omni-directional antenna, RP-SMA (male)

**Connector for External Antennas:** RP-SMA (female)

### Physical Characteristics

**Weight:** 220 g

**Dimensions:** 104 x 121 x 34 mm (4.09 x 4.76 x 1.34 in)

### Environmental Limits

**Operating Temperature:** -25 to 55°C (-13 to 131°F), EN 50155 Class T1

## EPM-3438 Specifications

### Digital Input

**Input Channels:** 8, source type

**Input Voltage:** 0 to 30 VDC at 25 Hz

**Digital Input Levels for Dry Contacts:**

- Logic level 0: Close to GND
- Logic level 1: Open

**Digital Input Levels for Wet Contacts:**

- Logic level 0: +3 V max.
- Logic level 1: +10 V to +30 V (Source to DI)

**Counter Frequency:** 2 KHz (DI0 only)

**Connector Type:** 10-pin screw terminal block (8 DI points, DI Source, GND)

**Isolation:** 3 KV optical isolation

### Digital Output

**Output Channels:** 8, sink type, 0 to 30 VDC

**Output Current:** Max. 200 mA per channel

**On-state Voltage:** 24 VDC nominal, open collector to 30 VDC

**Connector Type:** 9-pin screw terminal block (8 DO points, GND)

**Isolation:** 3 KV optical isolation

### Physical Characteristics

**Weight:** 120 g

**Dimensions:** 104 x 121 x 34 mm (4.09 x 4.76 x 1.34 in)

### Environmental Limits

**Operating Temperature:** -40 to 70°C (-40 to 158°F), EN 50155 Class TX

## EPM-3552 Specifications

### Display

**Graphics Controller:** DisplayLink DL-195

**VGA Interface:** 15-pin D-sub connector (female)

**DVI Interface:** 24-pin DVI-I connector (female)

**Resolution:** Up to 1920x 1600 (2048 x 1152 for wide screen) resolution

### Physical Characteristics

**Weight:** 130 g

**Dimensions:** 104 x 121 x 34 mm (4.09 x 4.76 x 1.34 in)

### Environmental Limits

**Operating Temperature:** -25 to 55°C (-13 to 131°F)

## EPM-DK01 Specifications

### PCI Express Mini Slot

**Interface:** PCIExpress V1.0 (one lane)

**USB 2.0 Bus SIM Card Holder:** Reserved for Cellular applications

### Mini PCI Slot

**Interface:** PCI

**Bus Frequency:** 32-bit, 33 MHz PCI

### Physical Characteristics

**Weight:** 117 g

### Environmental Limits

**Operating Temperature:** -40 to 70°C (-40 to 158°F), EN 50155 Class TX

## EPM-DK02 Specifications

### PCI Express Mini Slot

**Interface:**

Slot 1: PCIExpress V1.0 (one lane) / USB 2.0

Slot 2: USB 2.0

**USB 2.0 Bus SIM Card Holder:** Reserved for cellular applications

### Physical Characteristics

**Weight:** 125 g

### Environmental Limits

**Operating Temperature:** -25 to 55°C (-13 to 131°F), EN 50155 Class T1

## EPM-DK03 Specifications

### PCI Express Mini Slot

**Interface 1:** PCIExpress V1.0 (one lane) / USB 2.0

**Interface 2:** USB 2.0

**USB 2.0 Bus SIM Card Holder:** Reserved for cellular applications

### GPS Interface

**Acquisition:**

- Cold starts: 28s
- Warm starts: 28s
- Aided starts: 1s
- Hot starts: 1s

**Sensitivity:**

- Tracking: -160 dBm
- Reacquisition: -160 dBm
- Cold starts: -147 dBm

**Timing accuracy:**

- RMS: 30 ns
- 99%: <60 ns
- Granularity: 21 ns

**Accuracy:**

- Position: 2.5m CEP
- SBAS: 2.0m CEP

**Protocols:** NMEA; UBX binary, 5Hz max. update rate (ROM version )

**Time Pulse:** 0.25Hz to 1KHz

**Velocity Accuracy:** 0.1 m/s

**Heading Accuracy:** 0.5 degrees

**A-GPS:** Supports AssistNow Online and AssistNow Offline, OMA SUPL compliant

**Velocity Limit:** 500m/s (972 knots)

### Physical Characteristics

**Weight:** 125 g

**Dimensions:** 104 x 121 x 34 mm (4.09 x 4.76 x 1.34 in)

### Environmental Limits

**Operating Temperature:** -25 to 55°C (-13 to 131°F), EN 50155 Class T1

## EPM-3338 Specifications

### PCI Express Mini Slot

**Interface 1:** PCIExpress V1.0 (one lane) / USB 2.0

**Interface 2:** USB 2.0

**USB 2.0 Bus SIM Card Holder:** Reserved for cellular applications

### GPS Interface

#### Acquisition:

- Cold starts: 28s
- Warm starts: 28s
- Aided starts: 1s
- Hot starts: 1s

#### Sensitivity:

- Tracking: -160 dBm
- Reacquisition: -160 dBm
- Cold starts: -147 dBm

#### Timing accuracy:

- RMS: 30 ns
- 99%: <60 ns
- Granularity: 21 ns

#### Accuracy:

- Position: 2.5m CEP
- SBAS: 2.0m CEP

**Protocols:** NMEA; UBX binary, 5Hz max. update rate (ROM version )

**Time Pulse:** 0.25Hz to 1KHz

**Velocity Accuracy:** 0.1 m/s

**Heading Accuracy:** 0.5 degrees

**A-GPS:** Supports AssistNow Online and AssistNow Offline, OMA SUPL compliant

**Velocity Limit:** 500m/s (972 knots)

### Physical Characteristics

**Weight:** 125 g

**Dimensions:** 104 x 121 x 34 mm (4.09 x 4.76 x 1.34 in)

### Environmental Limits

**Operating Temperature:** -25 to 55°C (-13 to 131°F), EN 50155 Class T1

### V2400 Wi-Fi Accessory Kit

**Note:** This Wi-Fi package must be installed by users

**Standards:** 802.11a/b/g/n

**Chipset:** Mac/BB/RF Atheros AR9382

**Host Interface:** Half Mini PCI Express

#### Radio

**Antenna:** 2 x U.FL connectors, 2T2R

#### Operating Frequencies:

- 802.11b/g/n ISM Band: 2.412 ~ 2.4835 GHz
- 802.11a ISM Band: 5.15 ~ 5.85 GHz

**Modulation:**

- 802.11a: OFDM (BPSK, QPSK, 16-QAM, 64-QAM)
- 802.11b: DSSS (DBPSK, DQPSK, CCK)
- 802.11g: OFDM (BPSK, QPSK, 16-QAM, 64-QAM)
- 802.11n: OFDM (BPSK, QPSK, 16-QAM, 64-QAM)
- 802.11gn HT20: 17dBm  $\pm$  1.5dBm@MCS15
- 802.11gn HT40: 16dBm  $\pm$  1.5dBm@MCS15
- 802.11an HT20: 13dBm  $\pm$  1.5dBm@MCS15
- 802.11an HT40: 12dBm  $\pm$  1.5dBm@MCS15

**Receive Sensitivity (2R):**

- 802.11a: -76dBm  $\pm$  2dBm@54Mbps
- 802.11b: -85dBm  $\pm$  2dBm@11Mbps
- 802.11g: -76dBm  $\pm$  2dBm@54Mbps
- 802.11gn HT20: -75dBm  $\pm$  2dBm@MCS7
- 802.11gn HT40: -71dBm  $\pm$  2dBm@MCS7
- 802.11an HT20: -71dBm  $\pm$  2dBm@MCS7
- 802.11an HT40: -71dBm  $\pm$  2dBm@MCS7

**V2400 HSPA Cellular Accessory Kit**

Note: This cellular package must be installed by users

**Frequency Bands:**

- UMTS/HSDPA: Triple band, 850/1900/1900/2100 MHz
- GSM/GPRS/EDGE: Quad band, 850/900/1800/1900 MHz
- Dual-band EV-DO/CDMA: 800/1900 MHz
- Prepared for 2100 MHz UMTS-AWS and EV-DO/CDMA

**Advanced RF Technologies:**

- Receive Diversity on all HSPA/UMTS/EV-DO/CDMA bands
- Receive equalization
- Standalone GPS and gpsOneXTRA™

**Data Speeds:**

- HSDPA/HSUPA DL/UL: 14.4 Mbps/5.76 Mbps
- WCDMA DL/UL: 384 kbps/384 kbps
- GSM DL/UL: 14.4 kbps/14.4 kbps
- GPRS DL/UL: 85.6 kbps/42.8 kbps
- EDGE DL/UL: 236.8 kbps/118.4 kbps
- EV-DO FL/RL: 3.1 Mbps/1.8 Mbps
- CDMA 1xRTT FL/RL: 153 kbps/153 kbps

**Power Class:**

- HSPA/WCDMA 800/850/900/1900/2100 Mhz: Power Class 3
- GSM/GPRS 850/900 Mhz: Power Class 4
- GSM/GPRS 1800/1900 Mhz: Power Class 1
- EDGE 850/900/1800/1900 Mhz: Power Class E2

# Hardware Introduction

---

The EPM Series expansion modules are designed to work with Moxa's V2422 and V2426 embedded computers. By providing different modules with different connectors, the EPM series offers the greatest flexibility and convenience for users who would like to easily establish industrial applications that require different communication interfaces.

The following topics are covered in this chapter:

## □ Appearance

- EPM-3032
- EPM-3112
- EPM-3337
- EPM-3438
- EPM-3552
- EPM-DK01
- EPM-DK02
- EPM-3338
- EPM-DK03

## □ Dimensions

# Appearance

## EPM-3032

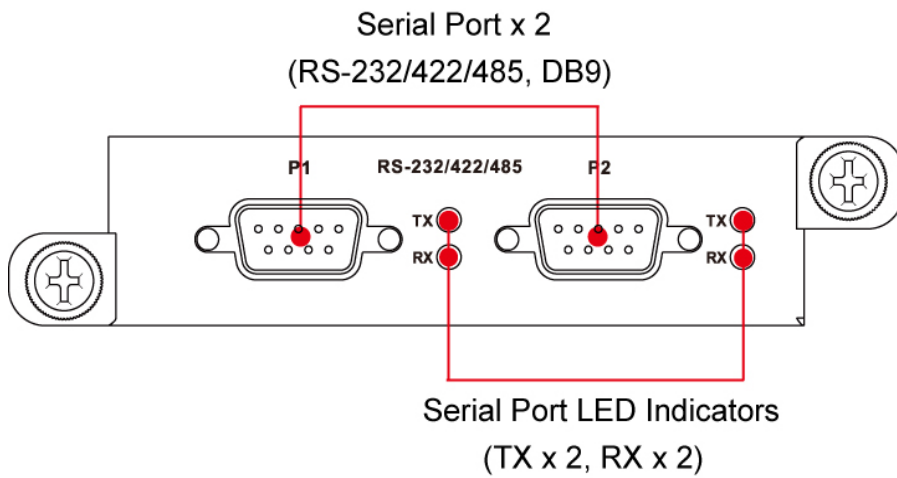

## EPM-3112

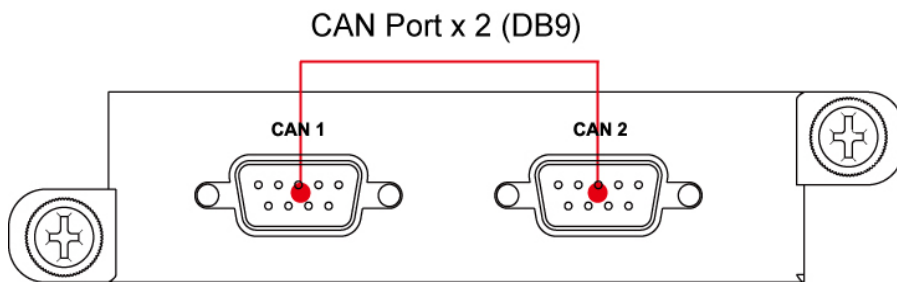

## EPM-3337

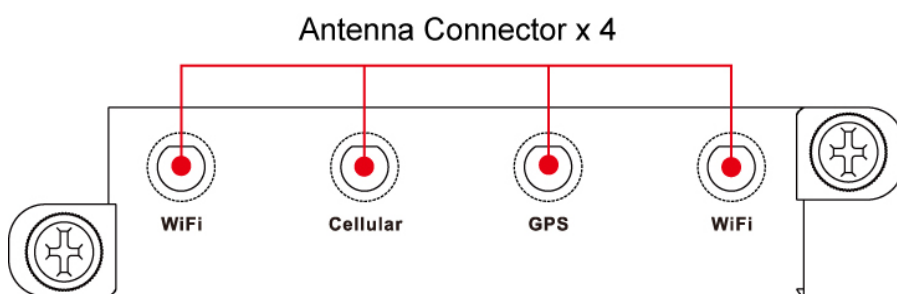

## EPM-3438

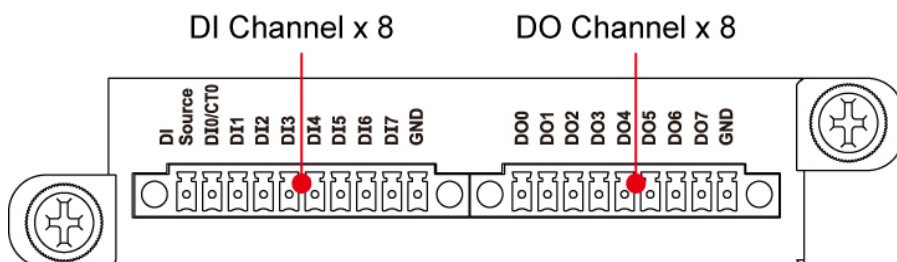

### EPM-3552

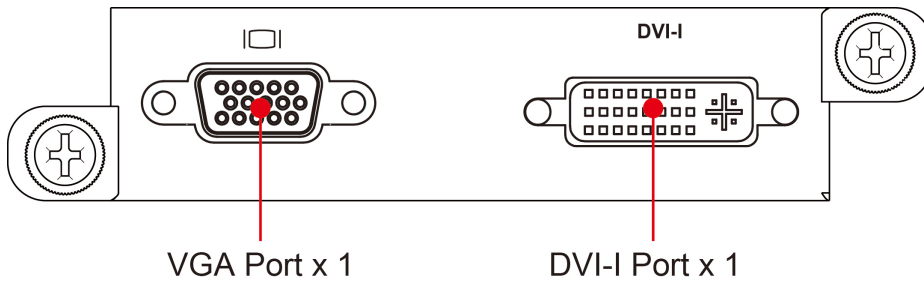

### EPM-DK01

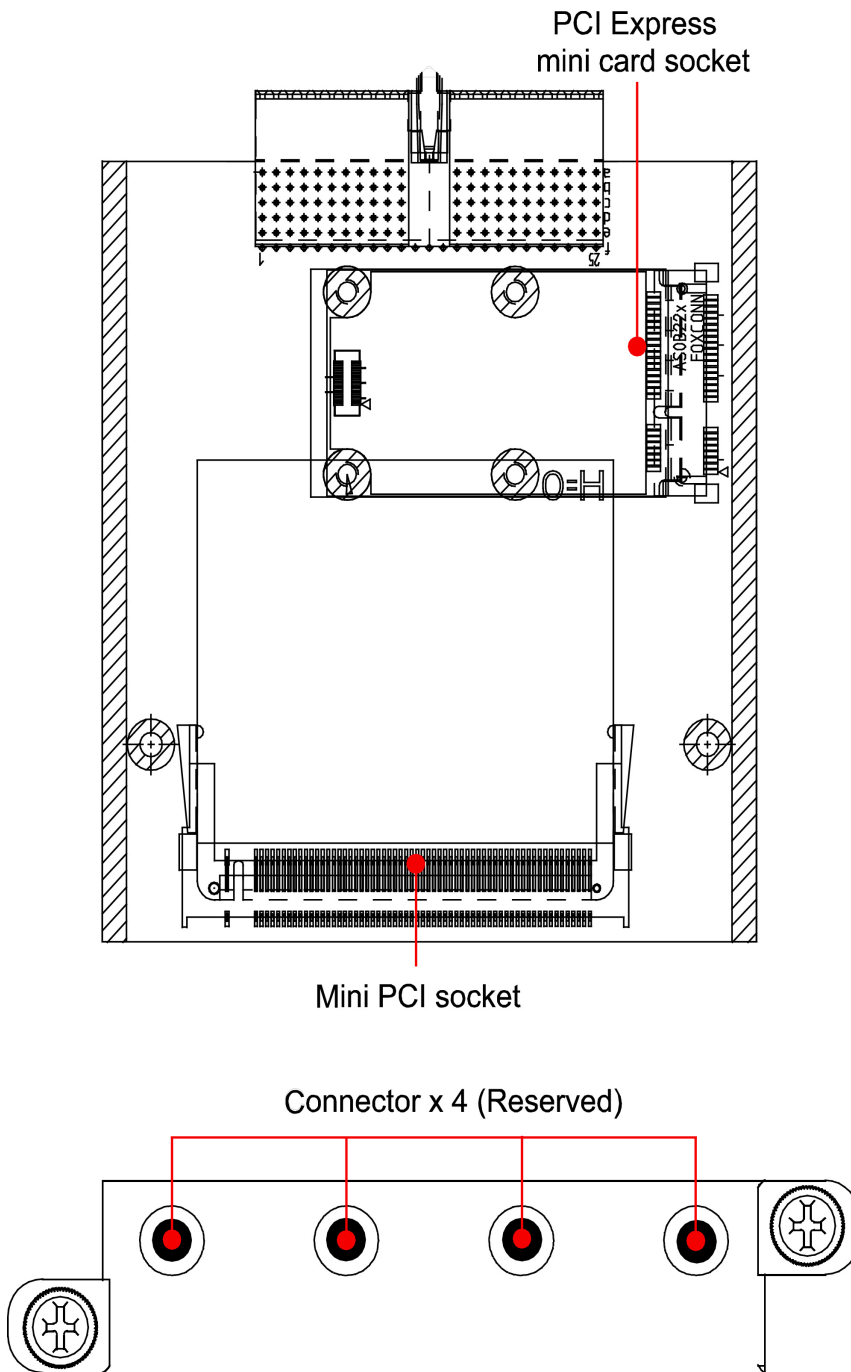

### EPM-DK02

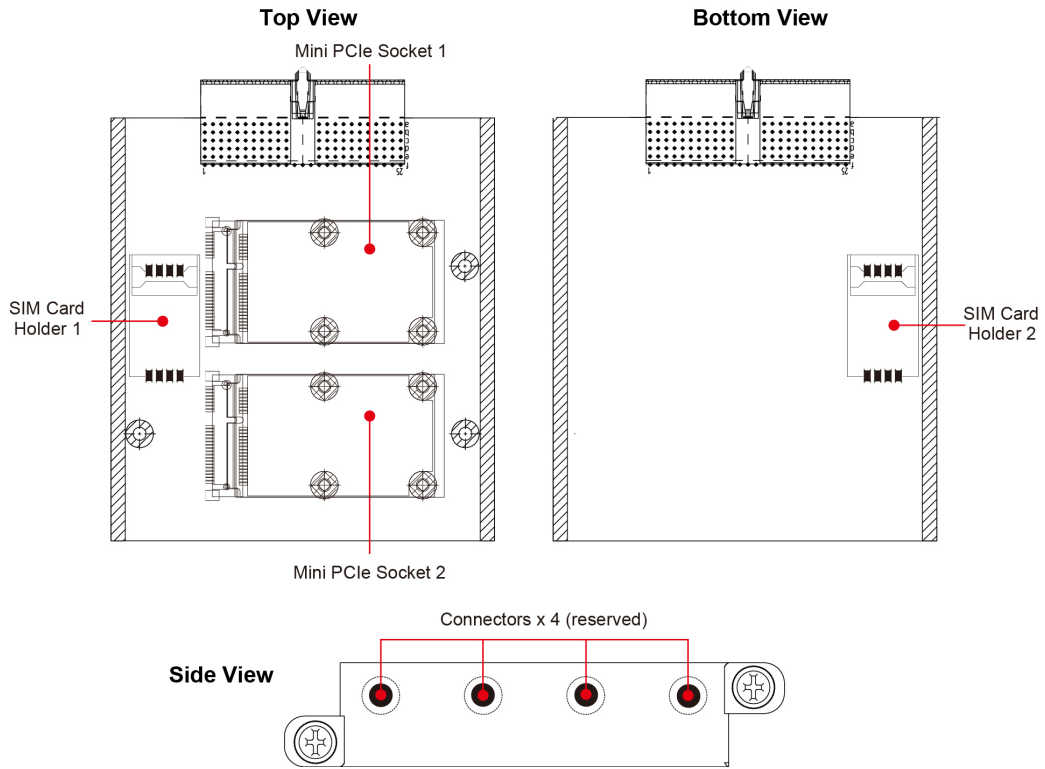

### EPM-3338

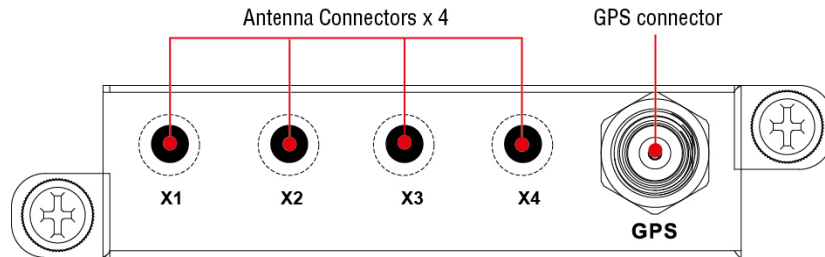



# EPM-DK03

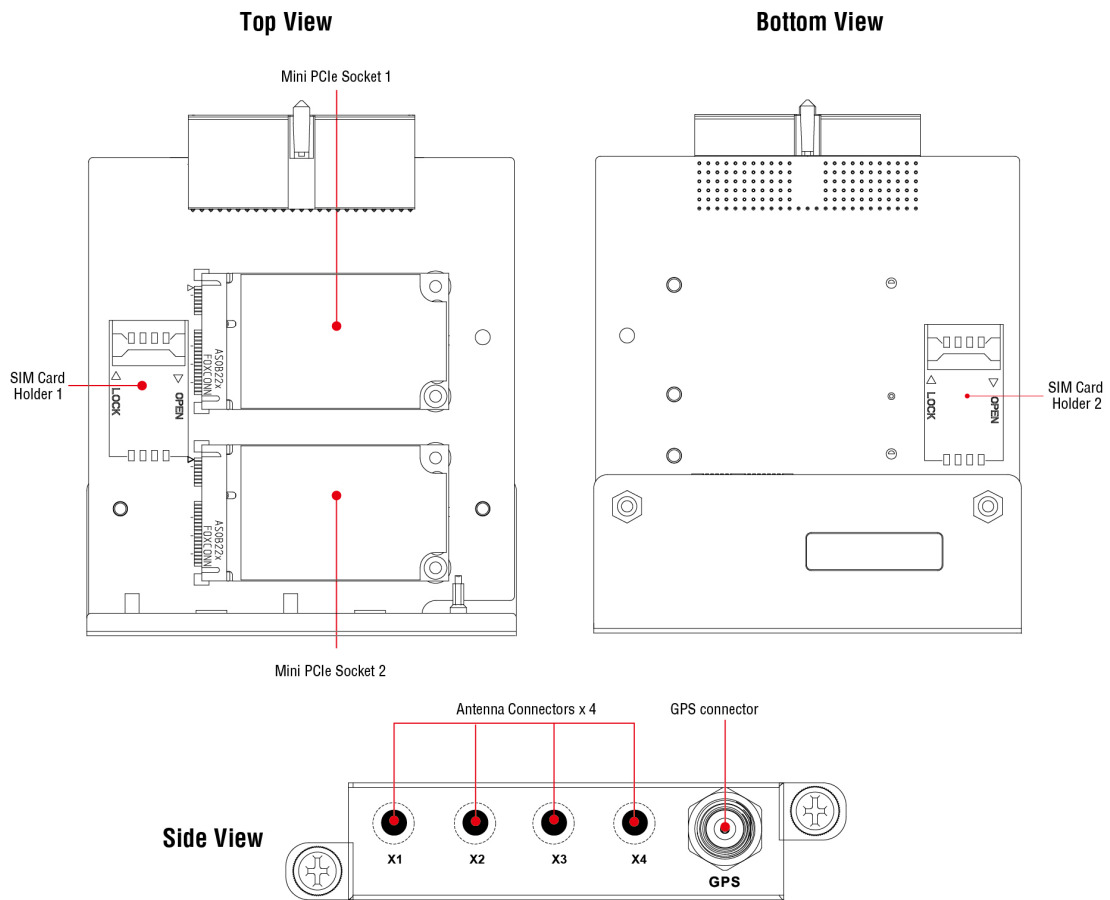

# Dimensions

All modules share the same dimensions.

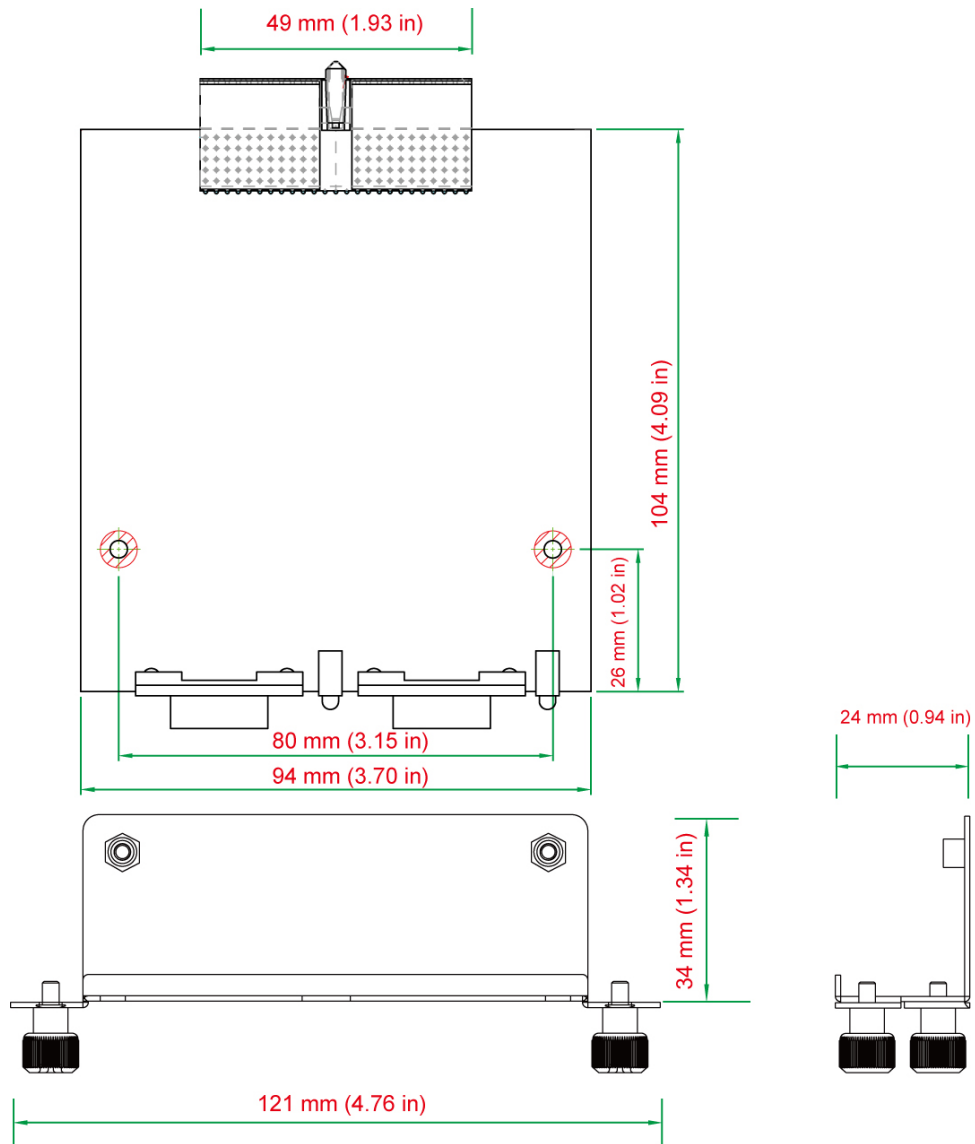

# Hardware Connection Description

---

In this chapter, we show how to connect the embedded computers to the network and to various devices.

The following topics are covered in this chapter:

❑ **Installing the EPM Expansion Modules**

❑ **Connecting Data Transmission Cables**

- EPM-3032 Serial Port Module
- EPM-3337 Wireless/GPS Module
- EPM-3438 DI/DO Module
- EPM-3112 CAN Bus Module
- EPM-DK01 Module: mini PCI + mini PCIe Sockets
- EPM-3552 Display Module
- EPM-DK02 Module: 2 mini PCIe Sockets

❑ **Installing Cellular/Wi-Fi Modules on the EPM-DK02, EPM-DK03, or EPM-3338**

- Configuring Power Controls on Socket 1
- Installing a Cellular Module
- Arranging Cables on the Wi-Fi or Cellular Modules

# Installing the EPM Expansion Modules

The EPM series expansion modules are designed to work with Moxa's V2422 and V2426 embedded computers. Below we describe how to insert the modules into the embedded computer slots.

1. Remove the module cover screws.

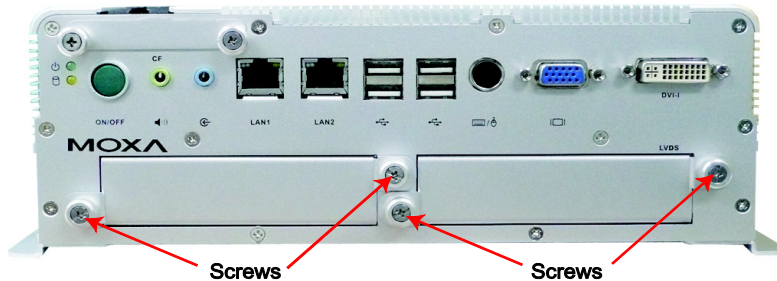

2. Remove the cover from the slot.



3. Gently insert the module into the slot.



4. When finished, tighten the screws to hold the module in place.

## Connecting Data Transmission Cables

In this section we explain how to connect the EPM modules to devices.

### EPM-3032 Serial Port Module

Use a serial cable to plug your serial device into the module's serial port. Serial ports 1 and 2 have male DB9 connectors and can be configured for RS-232, RS-422, or RS-485 communication by software. The pin assignments are shown in the table at the top of the page following.

**DB9 Male Port**      **RS-232/422/485 Pinouts**

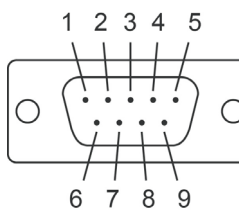

| Pin | RS-232 | RS-422  | RS-485 (4-wire) | RS-485 (2-wire) |
|-----|--------|---------|-----------------|-----------------|
| 1   | DCD    | TxDA(-) | TxDA(-)         | -               |
| 2   | RxD    | TxDB(+) | TxDB(+)         | -               |
| 3   | TxD    | RxDB(+) | RxDB(+)         | DataB(+)        |
| 4   | DTR    | RxDA(-) | RxDA(-)         | DataA(-)        |
| 5   | GND    | GND     | GND             | GND             |
| 6   | DSR    | -       | -               | -               |
| 7   | RTS    | -       | -               | -               |
| 8   | CTS    | -       | -               | -               |

### EPM-3337 Wireless/GPS Module

The EPM-3337 module comes with 4 connectors that can be used to connect antennas, including 2 Wi-Fi antennas, 1 cellular antenna, and 1 GPS antenna. Refer to the following figure for the location of the different antennas.

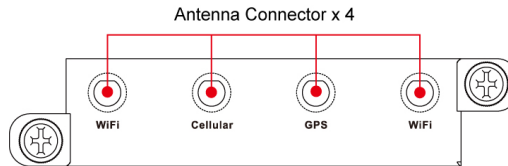

### EPM-3438 DI/DO Module

The EPM-3438 module comes with 8 digital input channels and 8 digital output channels. See the following figures for pin definitions and wiring methods.

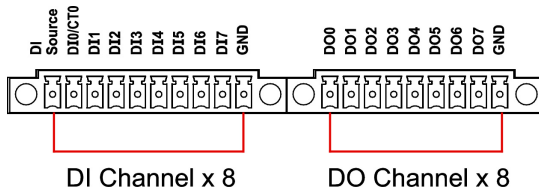

#### Digital Input Dry Contact Wiring

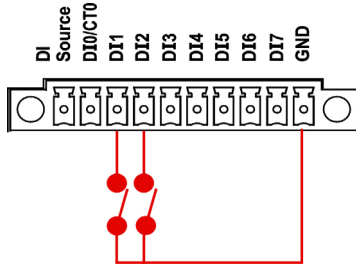

#### Digital Input Wet Contact Wiring

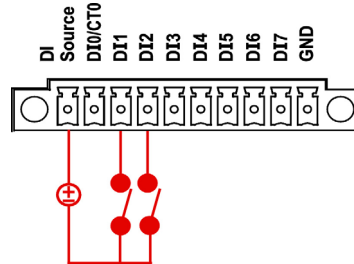

#### Digital Output Wiring

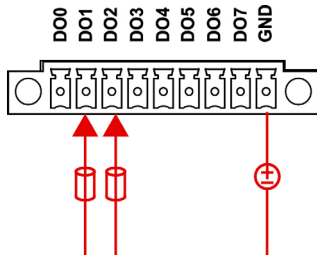

## EPM-3112 CAN Bus Module

The EPM-3112 offers two CAN bus ports with DB9 male connectors. Use a cable to plug your CAN device into the module's serial port. The pin assignments are shown in the following table:

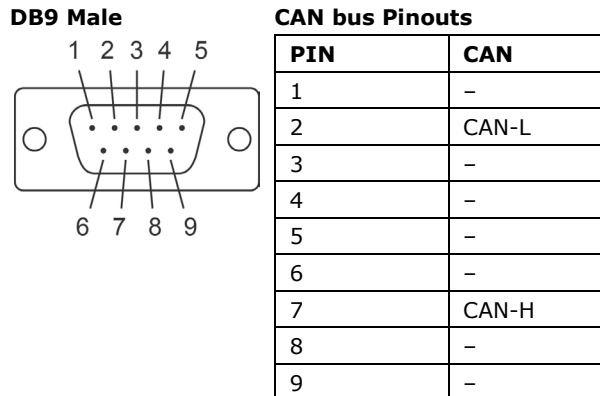

## EPM-DK01 Module: mini PCI + mini PCIe Sockets

The EPM-DK01 offers a mini-PCI and a mini-PCIe sockets, allowing users to insert a mini-PCI or a mini-PCIe card. See the following figure for the specific locations when installing these cards. Meanwhile, if you need to connect the antenna, use the connectors on the exterior panel.

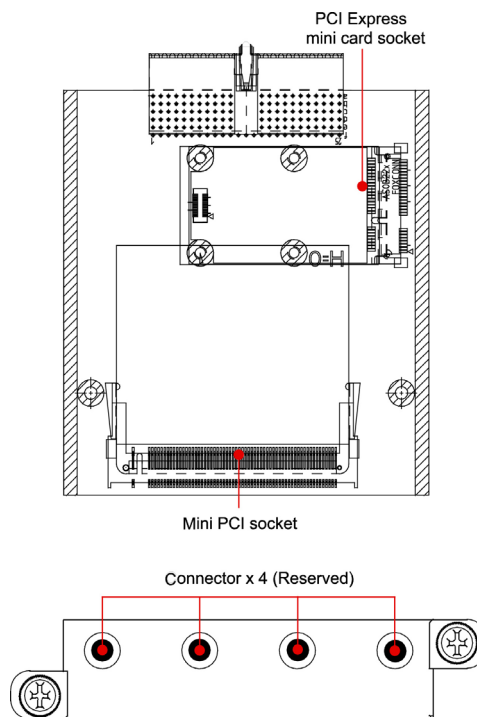

## EPM-3552 Display Module

The EPM-3552 display modules comes with a VGA connector and a DVI-I connector. Use a cable to connect the display to the connector on the module.

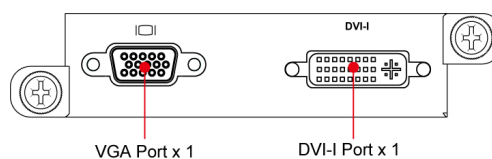

The pin assignments are shown in the tables on the next page.

**D-Sub 15 Connector Pin Assignments**

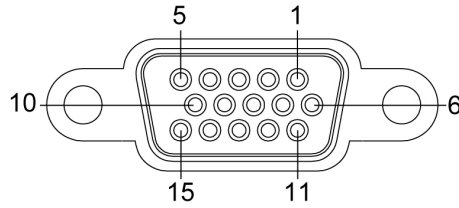

| Pin No. | Signal Definitions |
|---------|--------------------|
| 1       | RED                |
| 2       | GREEN              |
| 3       | BLUE               |
| 4       | -                  |
| 5       | GND                |
| 6       | CRT_DETECT#        |
| 7       | GND                |
| 8       | GND                |
| 9       | +5V                |
| 10      | GND                |
| 11      | -                  |
| 12      | DDC_DATA           |
| 13      | HSYNC              |
| 14      | VSYNC              |
| 15      | -                  |

**DVI-I Connector Pin Assignments**

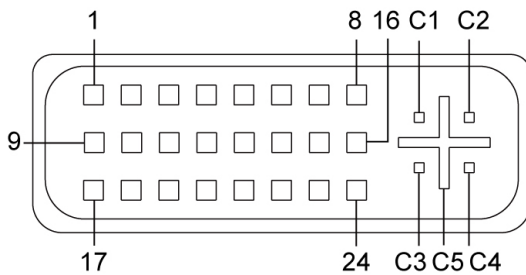

| Pin No. | Signal Definition                         |
|---------|---|
| 1       | T.M.D.S. Data2-                           |
| 2       | T.M.D.S. Data2+                           |
| 3       | T.M.D.S. Data2/4 Shield                   |
| 4       | T.M.D.S. Data4-                           |
| 5       | T.M.D.S. Data4-                           |
| 6       | DDC Clock                                 |
| 7       | DDC Data                                  |
| 8       | Analog Vertical Sync                      |
| 9       | T.M.D.S. Data1-                           |
| 10      | T.M.D.S. Data1+                           |
| 11      | T.M.D.S. Data1/3 Shield                   |
| 12      | T.M.D.S. Data3-                           |
| 13      | T.M.D.S. Data3+                           |
| 14      | +5V Power                                 |
| 15      | Ground (return for +5V, HSync, and VSync) |
| 16      | Hot Plug Detect                           |
| 17      | T.M.D.S. Data0-                           |
| 18      | T.M.D.S. Data0+                           |
| 19      | T.M.D.S. Data0/5 Shield                   |
| 20      | T.M.D.S. Data5-                           |
| 21      | T.M.D.S. Data5+                           |
| 22      | T.M.D.S. Clock Shield                     |
| 23      | T.M.D.S. Clock+                           |
| 24      | T.M.D.S. Clock-                           |
| C1      | Analog Red                                |
| C2      | Analog Green                              |
| C3      | Analog Blue                               |
| C4      | Analog Horizontal Sync                    |
| C5      | Analog Ground<br>(analog R, G, B return)  |

## EPM-DK02 Module: 2 mini PCIe Sockets

The EPM-DK02 has two mini PCIe sockets that may be used for cellular communications expansion. The figures below show the slots' specific locations. Note that while both sockets provide a mini PCIe interface, socket one supports either mini PCIe or USB 2.0 signals, whereas socket two only supports USB 2.0 signals.

Connect the cellular module to the mini PCIe socket, and insert the SIM card into the SIM card holder. Be sure to tighten the screw in the screw holder so that the module will be firmly installed. Note that the second SIM card holder is located on the back of the module. If you need to connect the antenna, use the connectors on the exterior panel.

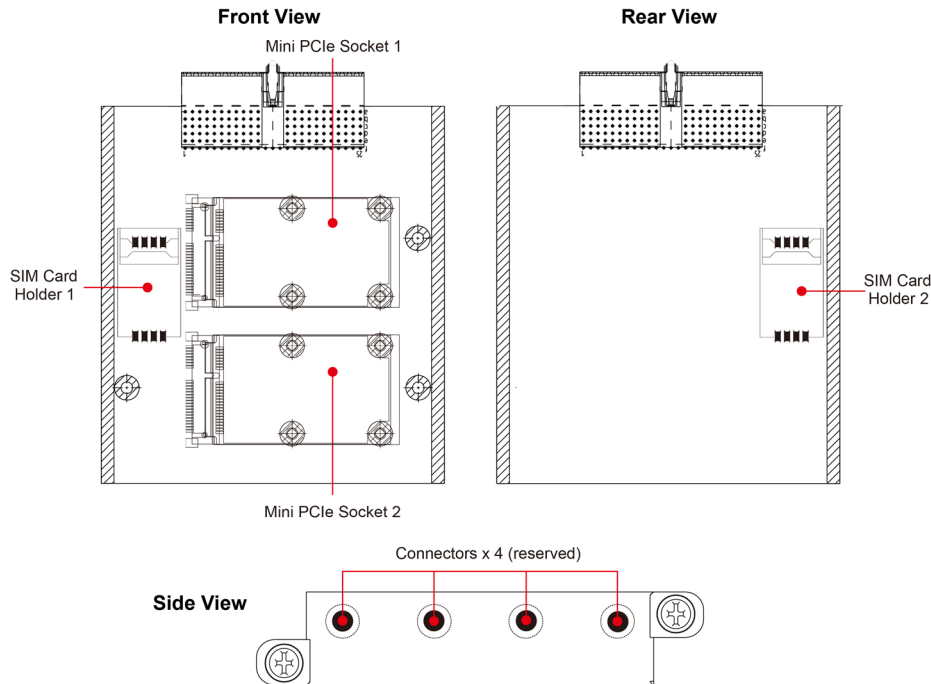

## Installing Cellular/Wi-Fi Modules on the EPM-DK02, EPM-DK03, or EPM-3338

The EPM-DK02/03/3338 has two mini PCIe sockets that allow users to insert two mini PCIe cards for cellular or Wi-Fi communication. Note that while both sockets provide a mini PCIe interface, socket 1 supports either mini PCIe or USB 2.0 signals, whereas socket 2 only supports USB 2.0 signals.

Users may purchase the cellular and Wi-Fi modules for the EPM-DK03 separately. The instructions for installing the cellular and Wi-Fi modules follow. For the convenience of installing the antenna, always install the module on Socket 2 first.

### Configuring Power Controls on Socket 1

To use socket 1 as a USB interface, the user must allow the platform's GPIO to control the power; in contrast, for the PCIe interface the power must be constantly on. These power controls must first be set at the hardware level, using the jumper shown in the figure at right.

1. To enable GPIO control of power for a USB interface, place the jumper on pins 1 and 2.
2. To disable power controls for an always-on PCIe interface, place the jumper on pins 2 and 3.

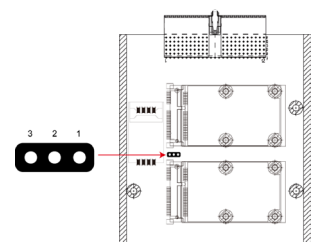

**NOTE** This jumper configuration is for socket 1 only.



## Installing a Cellular Module

The cellular accessory package includes a cellular module, a cellular antenna cable, four black screws, a thermal pad, a locking washer, a nut, and an O-ring. In addition, a printed quick installation guide is also included in the kit.

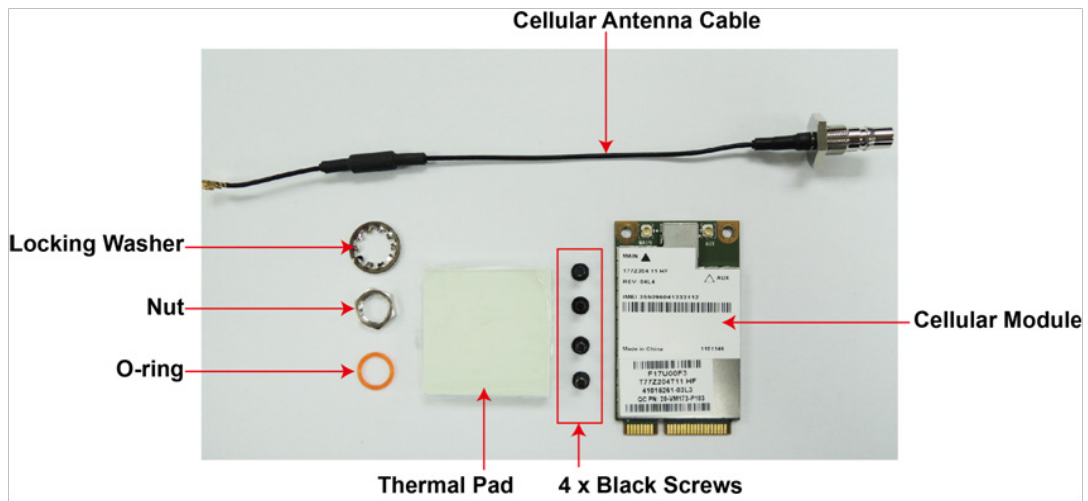

See the following steps to install the cellular module.

1. Remove the membranes on both sides of the thermal pad, and then place the thermal pad on the socket. When finished, you may insert the cellular module into the socket.

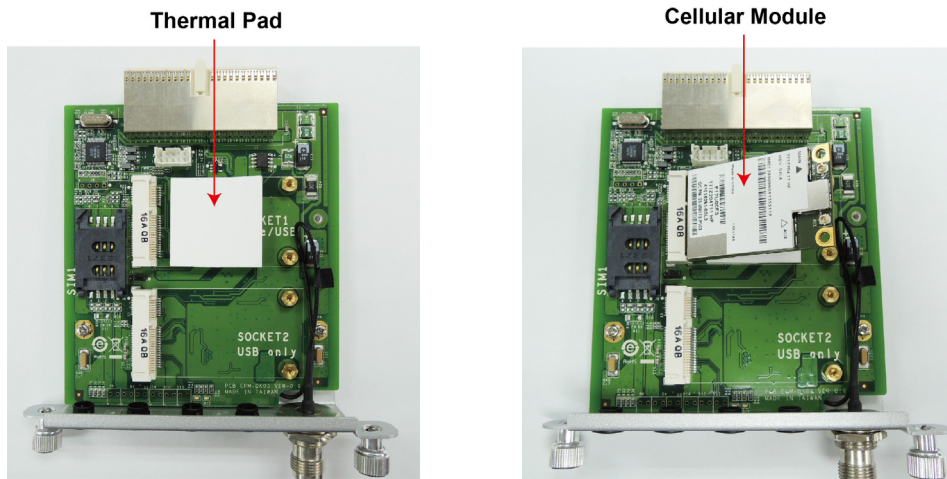

2. Fasten the module with 2 black screws. Connect the antenna cable on the module. Make sure that the cable has been securely fastened. See the following figures for the specific locations of the screws and the antenna cable connector.

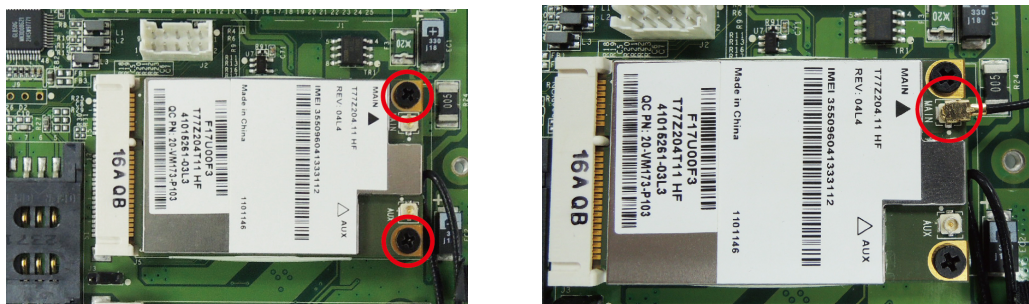

3. Insert the connector of the antenna cable into the O-ring. Remove the black cover from the antenna hole in the front side of the EPM-3338 module, and then insert the connector. Insert the locking washer first, and then fasten the nut to secure the connector (see figure on next page for detailed pictures).

O-ring

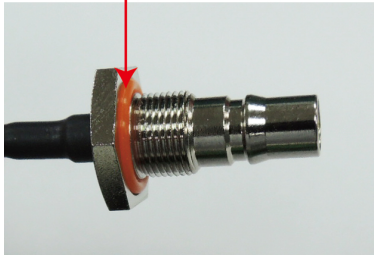

Locking Washer

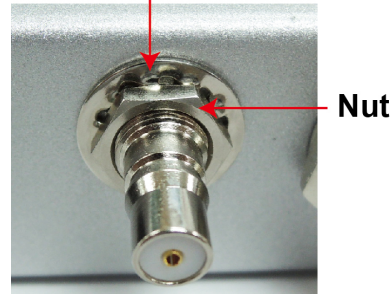

4. When finished, connect the cellular antenna to the connector. We suggest you install the antenna on the hole X2 or X3.
5. Next, insert the SIM card for the cellular module. Pull up the SIM card slot and insert the SIM card. When finished, replace the holder and slide the slot towards the catch to fasten the holder

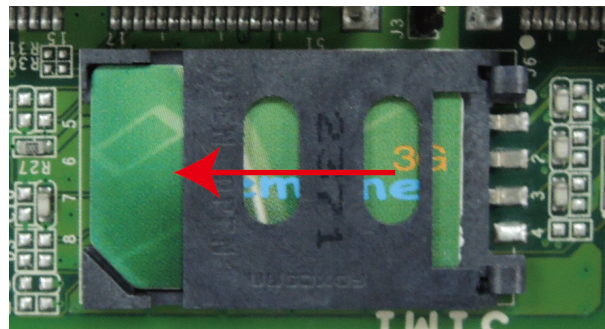
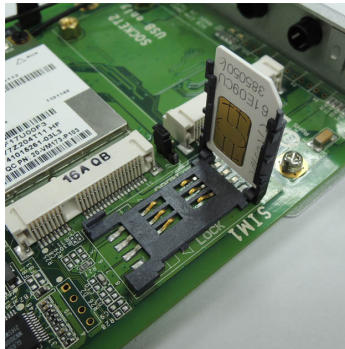

6. You can use the same procedure to install another cellular module on another socket. The second SIM card holder is located on the back of the EPM-3338 module
7. To complete the installation, please continue reading in to the section below, [Arranging Cables on the Wi-Fi or Cellular Modules.](#)

### Installing a Wi-Fi Module

Moxa’s Wi-Fi module accessory package includes a Wi-Fi module, a bracket, two Wi-Fi antenna cables, four black screws, two silver screws, a locking washer, a nut, and an O-ring. A printed quick installation guide is also included.

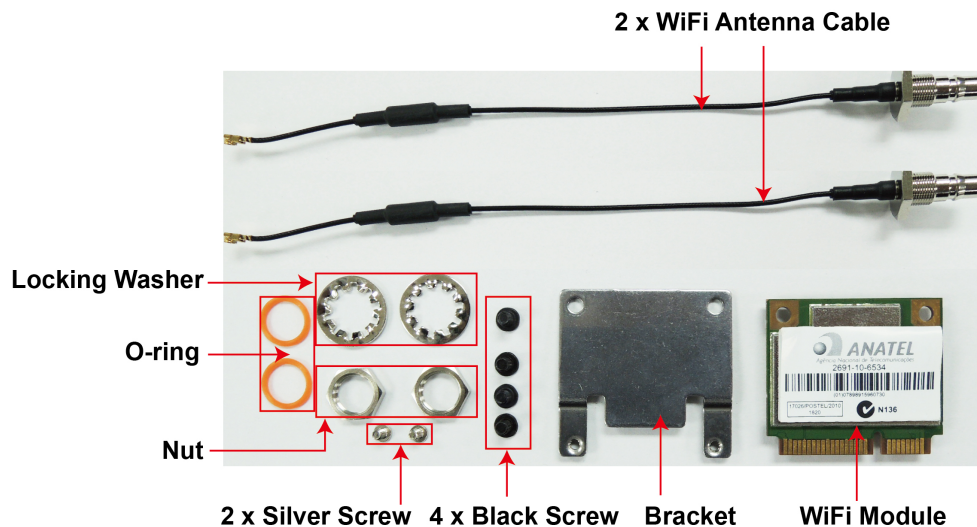

To install a Wi-Fi module:

1. Use the two silver screws to fasten the stabilization bracket to the Wi-Fi module. Make sure you connect the bracket in the correct direction: the two tongues which are attached to the Wi-Fi module should, after

installation, be positioned under the card (refer to the figure below for clarification). Insert the Wi-Fi module into Socket 1, and then fasten with the bracket into place using the two black screws. Please note that Wi-Fi module can only be inserted in Socket 1. See the following figures for details.



2. Connect the two antenna cables on the module. Make sure that these cables are securely fastened on the module.

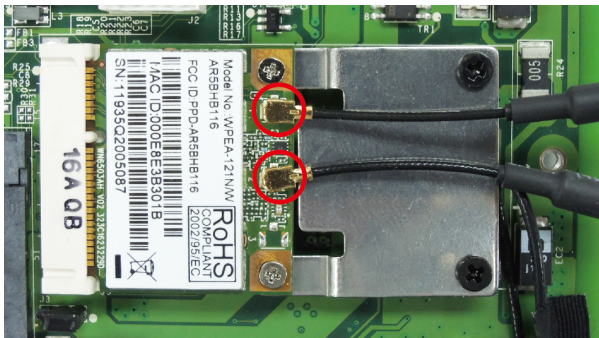

3. Insert the connector of the antenna cable into the O-ring. Remove the black cover from the antenna hole in the front side of the EPM-3338 module, and then insert the connector. Place the locking washer on the connector, and then fasten the nut to secure the connector.

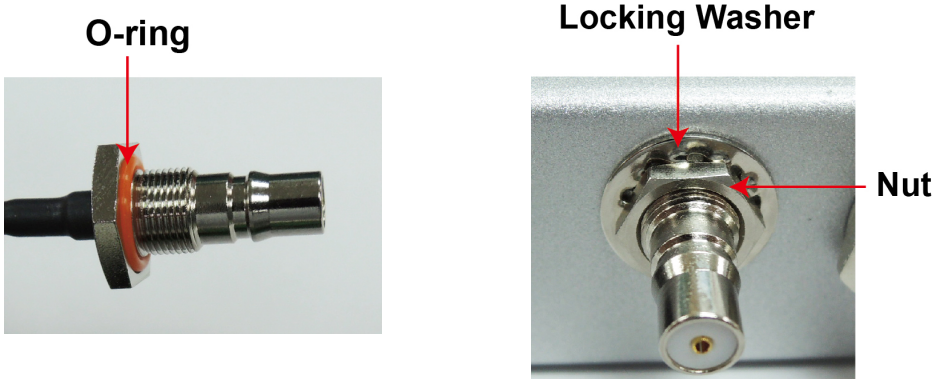

4. For best performance, the first connector should protrude from the X1 hole, and the second from the X4 hole.
5. To complete the installation, please continue reading in to the section below, [Arranging Cables on the Wi-Fi or Cellular Modules](#).

When finished, you may mount the EPM-3338/DK03 module into one of Moxa's V2400 Series embedded computers



**WARNING**

The Wi-Fi module can only be inserted into socket 1. Do not attempt to force it into socket 2.

## Arranging Cables on the Wi-Fi or Cellular Modules

After installing the cellular and Wi-Fi modules, make sure to arrange the cables properly within the chassis area. The proper arrangement is shown in the following photos.

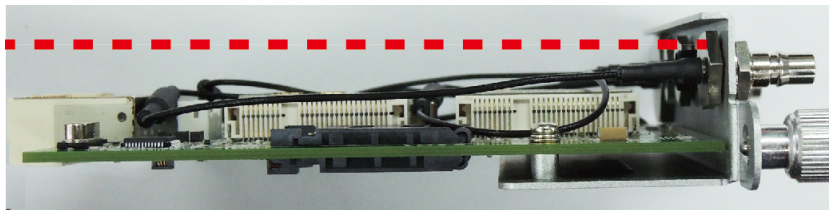
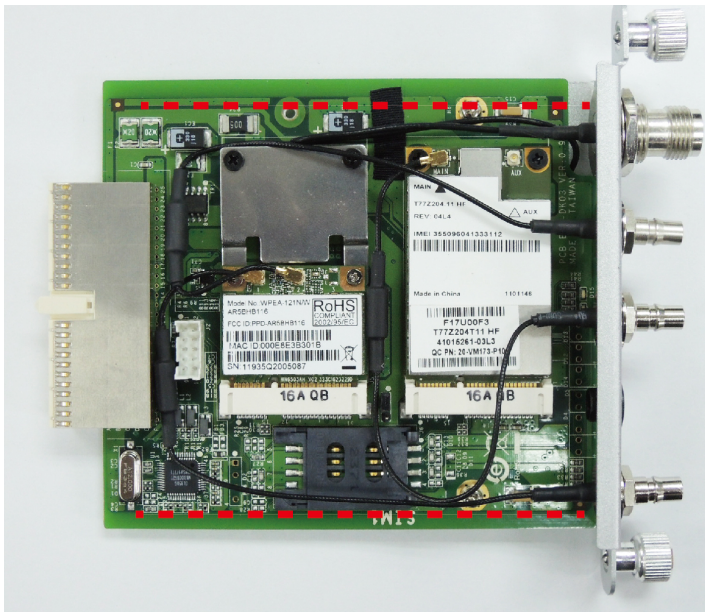

# Software Installation and Programming Guide

---

In this chapter we discuss software installation and programming guide for the EPM expansion modules 3032, 3337, 3338, DK02, and DK03.

The following topics are covered in this chapter:

- ❑ **Linux System Peripherals Programming Guide**
- ❑ **EPM-3032: Driver Installation**
  - EPM-3032: Configuring Baud Rate
  - EPM-3032: Configuring Serial Port Modes
- ❑ **EPM-3438: Driver Installation**
  - EPM-3438: Programming Digital I/O or the Counter
  - Implementing Timer Functions on Digital IO Ports
- ❑ **EPM-3337 Driver Installation**
  - EPM-3337: Operating Modes
  - EPM-3337: Setting up a Wi-Fi Connection
  - EPM-3337: Getting Wireless Card Information
- ❑ **EPM-3112: CAN Bus Interface**
  - EPM-3112: Driver Installation
  - EPM-3112: Programming Guide
- ❑ **EPM-3552: Driver Installation**
  - EPM-3552: Configuring the X Server
  - EPM-3552: Enabling a Dual Screen Display
  - EPM-3552: Configuring a Single Display
  - EPM-3552: Dynamically Changing the Display Resolution
- ❑ **EPM-DK02: Driver Installation**
  - EPM-DK02: Installing the Kernel Module
  - EPM-DK02: Configuring Power Controls
- ❑ **EPM-DK03: Driver Installation**
  - EPM-DK03: Installing the GPS Test Clients
- ❑ **EPM-3338: Driver Installation**
  - EPM-3338: Wi-Fi Module
  - EPM-3338: Cellular Module
  - EPM-3338: GPS Module
- ❑ **Windows System**
- ❑ **EPM-3032: Driver Installation**
  - EPM-3032: Configuring Serial Port Mode
  - EPM-3032: Changing the Software-Selectable UART Mode
- ❑ **EPM-3438: Driver Installation**
  - EPM-3438: Programming Guide
- ❑ **EPM-3337: Driver Installation**
  - EPM-3338: Wireless Module Driver Installation
  - EPM-3338: Configuring a GPRS/HSDPA Connection (no GPS)
  - EPM-3338: Configuring GPS
  - EPM-3338: Configuring a Wi-Fi/802.11 Connection
- ❑ **EPM-3112: Driver Installation**
  - EPM-3112: Programming Guide
- ❑ **EPM-3552: Driver Installation**
  - EPM-3552: Patch File Installation
  - EPM-3552: Display Configuration
  - EPM-3552: Configuring Extended Dual Displays
- ❑ **EPM-DK02: Driver Installation**
  - EPM-DK02: Controlling Power
- ❑ **EPM-DK03: Driver Installation**
  - EPM-DK03: GPS Driver Installation
  - EPM-DK03: Cellular Driver Installation
  - EPM-DK03: Wi-Fi Driver Installation
  - EPM-DK03: Configuring the Cellular Software Interface
  - EPM-DK03: Configuring a Wi-Fi Software Interface
- **EPM-DK03: Getting Wi-Fi Information**

# Linux System Peripherals Programming Guide

## EPM-3032: Driver Installation

The EPM-3032 may be accessed over the Linux console as a tty device node. The Moxa driver creates a special device node that is identified as a **ttym\*** device. The EPM-3032 device nodes are listed as **/dev/ttym8** and **/dev/ttym9**, or alternately as **/dev/ttym16** and **/dev/ttym17**. The UART API allows you to configure these device nodes for RS-232, RS-422, 4-wire RS-485, or 2-wire RS-485.

The EPM-3032 driver is **mxser.ko**, and has been pre-installed at **/lib/modules/2.6.30-bpo.2-686/kernel/drivers/char/mxser.ko**. It will be loaded automatically when the system boots up.

## EPM-3032: Configuring Baud Rate

### Example 1: Set the Modulation Rate / Baud)

```
#define MOXA                0x400
#define MOXA_SET_SPECIAL_BAUD_RATE    (MOXA+100)
#define MOXA_GET_SPECIAL_BAUD_RATE    (MOXA+101)
#include <termios.h>
    struct termios term;
    int fd, speed;
    fd = open("/dev/ttym8", O_RDWR);
    tcgetattr(fd, &term);
    term.c_cflag &= ~(CBAUD | CBAUDEX);
    term.c_cflag |= B4000000;
    tcsetattr(fd, TCSANOW, &term);
    speed = 115200;
    ioctl(fd, MOXA_SET_SPECIAL_BAUD_RATE, &speed);
```

### Example: Return the Modulation Rate / Baud

```
#define MOXA                0x400
#define MOXA_SET_SPECIAL_BAUD_RATE    (MOXA+100)
#define MOXA_GET_SPECIAL_BAUD_RATE    (MOXA+101)
#include <termios.h>
    struct termios term;
    int fd, speed;
    fd = open("/dev/ttym8", O_RDWR);
    tcgetattr(fd, &term);
    if ( (term.c_cflag & (CBAUD|CBAUDEX)) != B4000000 ) {
        // On this line, you may insert a standard baud rate
    } else {
        ioctl(fd, MOXA_GET_SPECIAL_BAUD_RATE, &speed);
    }
```

**ATTENTION**

Maximum baud for the serial ports is 115,200; the stock serial ports on the V2400 series do not support other bauds. However, the serial port expansion module does support modulation rates up to 921,600 baud. Standard bauds are: 50, 75, 110, 134, 150, 200, 300, 600, 1200, 1800, 2400, 4800, 9600, 19200, 38400, 57600, 115200, 230400, 460800, 921600. To configure the above code for a standard baud connection, simply insert the number at the indicated line.

If you use stty to get interface stats from a connection configured for a non-standard baud, the system will return a rate of 0.

## Modulation Rate Inaccuracy

Moxa's drivers allow engineers to configure our serial devices for non-standard baud rates. Theoretically, these devices may be set for any baud; however, in practice the only non-standard rates that will communicate at the chosen modulation rate are whole number factors of the base rate, 921,600 Bd. For any non-standard rates that are not a whole number factor of 921,600, there will be some inaccuracy in transmission speed relative to the configured rate.

Standard bauds are 50, 75, 110, 134, 150, 200, 300, 600, 1200, 1800, 2400, 4800, 9600, 19200, 38400, 57600, 115200, 230400, 460800, and 921600. Moxa's drivers allow for any whole number factor of 921,600 to be used without any performance loss (i.e., inaccuracy or deviation from the TBR) in the configured modulation rate. To calculate the relative inaccuracy for non-standard baud rates which are not a whole number factor of 921,600, users may use the formula below:

$$\text{Root formula: Inaccuracy} = \frac{\text{TBR} - 921600 / (\text{Factor} + \text{ENUM} / 8)}{(\text{TBR}) 100}$$

The variables in this equation above are described below:

**TBR** = The **Target Baud Rate**, i.e., any non-standard modulation rate, in baud

**Factor** = 921,600/TBR (rounded down to the integer)

**ENUM** = 8 \* (921600/Target baud - Factor) (Round up or down)

As an example, below we show you how to calculate the transmission inaccuracy at a target baud rate (TBR) of 500,000 bps:

Target (non-standard) Baud Rate = 500,000

Factor =  $\frac{921,600}{500,000} = 1.8$ , then round down to the nearest integer for 1.

ENUM =  $8 \left( \frac{921,600}{500,000} \right) - 1 = 6.7$ , round to the nearest integer for 7.

Inaccuracy =  $\frac{500,000 - 921600 / (1 + 7/8)}{(500,000) 100} = 1.696 = 1.7\%$

This result indicates that for a device configured at the non-standard rate of 500,000 Bd, the actual modulation rate will deviate around 2% from the configured baud.

## EPM-3032: Configuring Serial Port Modes

Use the `setinterface` command to retrieve the parameters of the serial port configuration. The usage is `$.~# setinterface [device node] [interface option]`. The **device node** is the tty device to be configured. For the serial ports, Moxa uses a proprietary driver whose device nodes are identified with the marker **M**. Serial ports 1 and 2 (respectively) on card 1 are referred to as **ttyM8** and **ttyM9**, and **ttyM16** and **ttyM17** refer to ports 1 and 2 (respectively) on the second card. The **interface option** is a number between 0 and 4 that will determine what serial interface should be configured for the port in question. For example:

```
$:~# setinterface /dev/ttyM8 0
```

sets the first serial port on the first card for RS-232 communications. Refer to the examples below for details.

```
Moxa:~# setinterface
Usage: setinterface device-node [interface-no]
device-node - /dev/ttyMn; n = 0,1,2,...
interface-no  - following:
none - to view now setting
0 - set to RS232 interface
1 - set to RS485-2WIRES interface
2 - set to RS422 interface
3 - set to RS485-4WIRES interface
Moxa:~#
```

## Checking Current Serial Settings

To check the current interface setting, type the following. The system should display a response as below.

```
Moxa: ~# setinterface /dev/ttyM8
Now setting is RS485-2WIRES interface.
```

In the example above, port 1 on card 1 is configured as a 2-wire RS-485 interface. After entering the lines of code below, port 1 gets reset as an RS-422 interface.

```
Moxa: ~# setinterface /dev/ttyM8 2
Moxa: ~# setinterface /dev/ttyM8
Now setting is RS422 interface.
```



### ATTENTION

Serial interfaces **will shift device node identifiers** depending upon the location and number of cards mounted in the platform, e.g. if there are originally two cards mounted in the machine, and card number 1 is removed, then the second card's will change from **/dev/ttyM16** and **/dev/ttyM17** to **/dev/ttyM8** and **/dev/ttyM9**.

If a user wants to configure the machine for fixed serial interface device node identifiers, you can create a UDEV rule in **/etc/udev/rules.d/**. For help with this, you may consult the UDEV manual files, another Linux manual, or Moxa technical support for more details.

The system default for EPM-3032 interfaces is RS-232. By editing the device manager's rule scripts, it is possible to set all serial ports to one of the serial protocols (RS-485 or RS-422) instead. The steps describe how to do so.

1. First remount the read-only root file system in writable mode.

```
Moxa:~# mount -o remount, rw /dev/hda1 /
```

2. Next, edit the Moxa's custom rules file for the device manager. That will be found at **/etc/udev/rules.d/96-moxa.rules**. Add the following command to **96-moxa.rules**:

```
RUN+="/bin/setinterface /dev/ttyM%n 0"
```

```
# Set the device, EPM-3032, 0x1393:0x1022 default as 232 mode interface
DRIVERS=="mxser", ATTRS{vendor}=="0x1393", ATTRS{device}=="0x1022",
RUN+="/bin/setinterface /dev/ttyM%n 0"
```

```
"96-moxa.rules"
```



**ATTENTION**

The **VendorID** for the EPM-3032 is **0x1393m**, and the **DeviceID** is **0x1022**.

3. To change the default serial interface mode, edit the `setinterface` command you have just added to the Moxa rules file (`/etc/udev/rules.d/96-moxa.rules`). This will cause the Linux kernel to automatically set the V2400 module to your preferred interface at every reboot.

- For RS-232, use `RUN+="/bin/setinterface /dev/ttyM%n 0"`
- For RS-485 2-wire, use `RUN+="/bin/setinterface /dev/ttyM%n 1"`
- For RS-422, use `RUN+="/bin/setinterface /dev/ttyM%n 2"`
- For RS-485 4-wire, use `RUN+="/bin/setinterface /dev/ttyM%n 3"`

4. When finished, you must un-mount the writable file system and reboot your computer

```
Moxa:~# umount /
Moxa:~# reboot
```

5. Once the computer restarts, confirm that the interfaces have been reset to the default settings.

```
Moxa:~# setinterface /dev/ttyM8
Now setting is RS485-2WIRES interface.
```

## EPM-3438: Driver Installation

Upload the driver package to `/dev/shm`, a temporary file system on your computer.

```
root:~# scp epm3438-2.6.30-bpo.2-686.deb root@192.168.30.123:/dev/shm
```

Install the package

```
Moxa:~# cd /dev/shm
Moxa:~# mount -o remount, rw /
Moxa:~# dpkg -i ./epm3438-2.6.30-bpo.2-686.de
Moxa:~# umount /
```

After the driver installs, you can use `lsmod` to check if the `epm3438` module is loaded in the kernel.

```
Moxa:~# lsmod|more
Module                Size  Used by
epm3438                4620  0
...
```

To force the drivers to automatically load at boot time, you must edit `/etc/init.d/moxainit.sh`. Using your editor of choice (below, we use VI), open up the `moxainit` script and then add the **`modprobe epm3438`** and **`modprobe -r epm3438`** lines.

```
Moxa:~# vi /etc/init.d/moxainit.sh
...
start)
...
    modprobe moxa_device_dio device="v2400"
    modprobe mxser
    modprobe epm3438
    ...
    ;;
stop)
...
    modprobe -r epm3438
    modprobe -r moxa_swtd
    modprobe -r moxa-device-dio
    ;;
...
```

If you need to uninstall the driver, you can use this command:

```
Moxa:~# mount -o remount,rw /
Moxa:~# dpkg -r epm3438
Moxa:~# umount /
```

After uninstalling the module, it is advisable to comment out or remove the entries in your `moxainit` script.

## EPM-3438: Programming Digital I/O or the Counter

Digital input/output channels for the V2400 series are provided by module EPM-3438. These channels can be accessed at run-time for control or monitoring using the functions in the following sections. Each of the digital output (DO) channels can be individually set to default to high or low. The digital input (DI) channels can be used to detect the state change of the digital input signal. The header file of digital I/O functions is `mxdgio.h`, which is located in the `digit_input_change` directory for Linux.

The EPM-3438 module may alternatively be used as a hardware counter, allowing engineers to log the number of times an I/O event occurs as it switches from high to low. The hardware counter is exclusive to normal digital I/O operations, but is useful for monitoring and analysis of state changes that occur continually at low frequencies.

### Moxa API Functions for DI/DO

|             |  |
|-------------|--|
| Function    | <b>HANDLE mxdgio_epm3438_open(int HWIndex);</b>  |
| Description | This function opens access to the DIO device.  |
| Input       | <HWIndex> The first or second EPM-3438 board.  |
| Output      | None   |
| Return      | When successful, this function gives access to the DIO device. Otherwise, there is an error. |

|             |  |
|-------------|--|
| Function    | <b>void mxdgio_close(HANDLE fd);</b>               |
| Description | This function closes the access to the DIO device. |
| Input       | <fd> The access to the device.                     |
| Output      | None   |
| Return      | None   |

|             |  |
|-------------|--|
| Function    | <b>int mxdgio_get_input_signal(HANDLE fd, int port);</b>   |
| Description | This function gets the signal state of a digital input channel.  |
| Input       | <fd> The access to the device.<br><port> port #  |
| Output      | <state> DIO_HIGH (1) for high, DIO_LOW (0) for low   |
| Return      | Returns 1 for a high signal or 0 for a low signal, if successful. Otherwise, it returns a value of -1. |

|             |  |
|-------------|--|
| Function    | <b>int mxdgio_get_output_signal(HANDLE fd, int port);</b>  |
| Description | This function gets the signal state of a digital output channel.                                       |
| Input       | <fd> The access to the device.<br><port> Port number   |
| Output      | None   |
| Return      | Returns 1 for a high signal or 0 for a low signal, if successful. Otherwise, it returns a value of -1. |

|             |  |
|-------------|--|
| Function    | <b>int mxdgio_set_output_signal_high(HANDLE fd, int port);</b>                 |
| Description | This function sets digital output channel to high.                             |
| Input       | <fd> The access to the device.<br><port> Port number.                          |
| Output      | none.  |
| Return      | When successful, this function returns 0. When an error occurs, it returns -1. |

|             |  |
|-------------|--|
| Function    | <b>int mxdgio_set_output_signal_low(HANDLE fd, int port);</b>                  |
| Description | This function sets a digital output channel to low.                            |
| Input       | <fd> The access to the device.<br><port> Port number.                          |
| Output      | none.  |
| Return      | When successful, this function returns 0. When an error occurs, it returns -1. |

## Moxa I/O Control Definitions for the Counter Mode

This table shows the API for using the counter mode on the EMP-3438 module. The counter mode already features de-bounce adjustments, so it should be usable immediately after programming and configuration. To access the counter values, engineers must open a device node to retrieve the counter's file descriptor. To read the counter value on a single EPM-3438, use COUNTER\_NODE1. If you have a second EMP-3438 module and wish to read the counter for that, you may use COUNTER\_NODE2.

```
#define COUNTER_NODE1 "/dev/epm_3438_counter1"
#define COUNTER_NODE2 "/dev/epm_3438_counter2"
```

|             |   |
|-------------|---|
| Function    | <b>mxdgio_epm3438_get_counter(int fd);</b>                    |
| Description | Gets the counter value  |
| Input       | <fd> The access to the counter device.<br><port> Port number. |
| Output      | none.   |
| Return      | the counter value   |

|             |   |
|-------------|---|
| Function    | <b>mxdgio_epm3438_clear_counter(int fd);</b>                  |
| Description | Clears the counter value                                      |
| Input       | <fd> The access to the counter device.<br><port> Port number. |
| Output      | none.   |
| Return      | 0:clear success; -n: clear fail                               |

## mxdgio.h: The Moxa Digital Input/Output Headers

1. On the software CD that was included with your computer Moxa provides sample code to illustrate some implementations of common DI/DO functions. To find these sample files, navigate to the directory `/V2100.V24XX/EPM3438/digit_input_change` on the CD that is bundled with your module; there, you will find the **mxdgio.h** file, which provides a convenient set of macros and an API for either digital I/O or counter programming.
2. The default initial value for digital output is **HIGH**. If you want to set the initial output status to **LOW**, you may instruct the kernel to load **epm\_3438.ko** with a default **LOW** setting at boot time. To do this, add the line `epm3438_DO2LOW=1` in `/etc/modules`. For the setting to initialize, you must reboot your computer or reload your kernel modules using the **modprobe** command:

```
$:~# modprobe -a
```

```
Moxa: ~# modinfo /lib/modules/2.6.30-bpo.2-686/kernel/drivers/char/epm_3438.ko
filename: /lib/modules/2.6.30-bpo.2-686/kernel/drivers/char/epm_3438.ko
description: EPM-3438: DIO/Counter module
author: jared_wu@moxa.com
license: GPL
depends:
```

```

vermagic:      2.6.30-bpo.2-686 SMP mod_unload modversions 686

parm:         epm3438_DO2LOW: Reset DO to LOW. 0. \
                Set DO to High (default). 1. \
                Set DO to LOW. (int)

Moxa: ~# mount -o remount, rw /

Moxa: ~# echo '# Load the EPM-3438 DIO driver' >> /etc/init.d/moxainit.sh.

Moxa: ~# echo 'modprobe epm_3438 epm3438_DO2LOW=1' >> /etc/init.d/moxainit.sh

Moxa: ~# umount /

```

## Registering Digital I/O Callback Events

Moxa provides a library of functions that allow a users to develop higher layer functions that respond to DI/O state changes. These functions allow user applications to create specific responses to digital I/O events by associating a callback function with an I/O event.

The source code files of the sample program are located in the `/example/V2100.V24XX/EPM3438/digit_input_change/` directory.

Four higher layer functions provide programmers with an API for timer callback events:

- `digit_io_timer_init`
- `digit_io_timer_dispatch`
- `digit_io_timer_add_callback`
- `digit_io_timer_dispatch_quit`

There are also four functions that give programmers an API for digital I/O callback events, available via the **`digit_io_timer_add_callback`** function:

- `DGTIO_GET_INPUT_STATE_CHANGE`
- `DGTIO_GET_INPUT`
- `DGTIO_GET_OUTPUT`
- `DGTIO_SET_OUTPUT`

The following is an example of the initialization function for registering a callback event.

```

mngr = digit_io_timer_init();
...
if (digit_io_timer_add_callback (mngr, HWIndex, port, DGTIO_GET_INPUT_STATE_CHANGE,
interval, input_chg_cb, &port) < 0) {
...
}
if (digit_io_timer_add_callback (mngr, HWIndex, port, DGTIO_GET_INPUT, interval,
input_get_cb, &port) < 0) {
...
}
if (digit_io_timer_add_callback (mngr, HWIndex, port, DGTIO_SET_OUTPUT, interval,
output_set_cb, &port) < 0) {
...
}
if (digit_io_timer_add_callback (mngr, HWIndex, port, DGTIO_GET_OUTPUT, interval,
output_get_cb, &port) < 0) {
...
}
digit_io_timer_dispatch(mngr);

```

## Implementing Timer Functions on Digital IO Ports

Here are two examples of DI/DO timer functions.

### Example 1

File and Folder: /example/V2100.V24XX/EPM3438/digit\_input\_change/digit\_io\_timer.c

```
#include <stdio.h>
#include <stdlib.h>
#if !defined(_WIN32_WCE) && !defined(WIN32)
#include <time.h>
#endif
#include "digit_io_timer.h"
/* callback function */
static void
dgio_input_change_exec(DGIOMNGR *mnggr, DGIOITEM *item)
{
    int sig;
    HANDLE fd=mnggr->fd[item->HWIndex];
    switch(item->mode)
    {
        case DGTIO_GET_INPUT:
            sig = mxdgio_get_input_signal(fd, item->port);
            item->cb(item->HWIndex, item->port, sig, item->arg);
            break;
        case DGTIO_GET_OUTPUT:
            sig = mxdgio_get_output_signal(fd, item->port);
            item->cb(item->HWIndex, item->port, sig, item->arg);
            break;
        case DGTIO_GET_INPUT_STATE_CHANGE:
            sig = mxdgio_get_input_signal(fd, item->port);
            if (item->last_signal!=sig)
            {
                item->cb(item->HWIndex, item->port, sig, item->arg);
            }
            break;
        case DGTIO_SET_OUTPUT:
            sig = item->cb(item->HWIndex, item->port, item->last_signal, item->arg);
            if (sig)
            {
                mxdgio_set_output_signal_high(fd, item->port);
            }
            else
            {
                mxdgio_set_output_signal_low(fd, item->port);
            }
            break;
        default:
            return;
    }
    item->last_signal = sig;
}
```

```

}

/**** release the timer operation ****/
static void
dgio_input_change_release(DGIOMNGR *mnggr)
{
    int i;
    DGIOITEM *item, *next;
    item=mnggr->list;
    while(item)
    {
        next = item->next;
        free(item);
        item = next;
    }
    for ( i=0; i<HW_TOTAL; i++ )
        if (mnggr->fd[i])
            mxdgio_close(mnggr->fd[i]);
}

/****
This function initializes a timer manager
Returns: Return a pointer to the manager.
****/

DGIOMNGR*
digit_io_timer_init(void)
{
    DGIOMNGR *mnggr;
    mnggr = (DGIOMNGR*) calloc(1, sizeof(DGIOMNGR));
    if (mnggr)
    {
        mnggr->fd[0] = mxdgio_open();
#ifdef 1 // Jared, 08-10-2010, support the second EPM-3438
        mnggr->fd[1] = mxdgio_epm3438_open(0); // The first EPM-3438
        mnggr->fd[2] = mxdgio_epm3438_open(1); // The second EPM-3438
#endif
        if (mnggr->fd[0] < 0)
        {
            free(mnggr);
            mnggr = NULL;
        }
    }
    return mnggr;
}

/****
adds a digital IO timer with a selected operation mode
Inputs:  \
<mnggr> timer manager \
<HWIndex> specify which hardware device; \
          0: embedded DIO, \
          1: EPM-3438 #1, \
          2: EPM-3438 #2 \
<port> specify which DIO pin \
<mode> the operation mode on the port \

```

```

    <interval> the interval (in milliseconds) between 2 calls \
        to a user-defined function \
    <cb> the user-defined callback function \
    <arg> argument to the function \
Returns: \
    0 on sucess, otherwise failure \
***/

int
digit_io_timer_add_callback(DGIOMNGR *mngnr, int HWIndex, int port, int mode, int
interval, digit_io_cb_t cb, void *arg)
{
    DGIOITEM *item;
    item = (DGIOITEM*) calloc (1, sizeof (DGIOITEM));
    if (!item)
        return -1;
    item->next = mngnr->list;
    mngnr->list = item;
    item->cb = cb;
    item->arg = arg;
    item->HWIndex = HWIndex; // Jared, 08-10-2010, HWIndex to support multiple boards
    item->port = port;
    item->mode = mode;
    item->interval = interval;
    item->next_time = interval;
    // Jared, 08-10-2010, HWIndex to support multiple boards
    item->last_signal = mxdgio_get_input_signal(mngnr->fd[HWIndex], port);
    return 0;
}

void
digit_io_timer_dispatch_quit(DGIOMNGR *mngnr)
{
    if (mngnr) mngnr->dispatch = 0;
}

#define MAX_TIME 0xFFFFFFFF
/** start and dispatch the timer operations \
Inputs: \
    <mngnr> the manager \
Returns: \
    none \
***/

void
digit_io_timer_dispatch(DGIOMNGR *mngnr)
{
    DGIOITEM *item;
    unsigned int ms_sleep, n;
#if !defined(_WIN32_WCE) && !defined(WIN32)
    struct timeval to;
#endif
    mngnr->dispatch = 1;
    while(mngnr->list && mngnr->dispatch)
    {
        for (item = mngnr->list; item != NULL; item = item->next)
        {

```

```

        if (mngr->now_time < item->next_time) /* not yet */
            continue;
    /** over due, executable */
    n = mngr->now_time - item->next_time;
    /** move to the next time */
    item->next_time = mngr->now_time+item->interval-n;
    dgio_input_change_exec(mngr, item);
    }
    ms_sleep = MAX_TIME;
    /** get the amount of time to sleep */
    for (item = mngr->list; item != NULL; item = item->next)
    {
        if (mngr->now_time < item->next_time) /** not yet */
        {
            n = item->next_time - mngr->now_time;
            if (n < ms_sleep) ms_sleep = n;
            continue;
        }
    }
    if (ms_sleep!=MAX_TIME)
    {
        #if !defined(_WIN32_WCE) && !defined(WIN32)
        to.tv_sec = ms_sleep/1000;
        to.tv_usec = (ms_sleep%1000)*1000;
        if (select (0, NULL, NULL, 0, &to) != 0) /* sleep */
            break;
        #else
        Sleep(ms_sleep);
        #endif
        mngr->now_time += ms_sleep;
    }
    }
    dgio_input_change_release(mngr);
}

```

## Example 2 (Implementing Timer Functions on Digital IO Ports)

File and Folder: /example/V2100.V24XX/EPM3438/digit\_input\_change/main.c

```

#include <stdio.h>
#include <stdlib.h>
#include "digit_io_timer.h"
static int
input_chg_cb(int HWIndex, int port, int sig, void *arg)
{
    printf("input_chg_cb() HWIndex %d port %d sig %d\n", HWIndex, port, sig);
    return 0;
}
static int
input_get_cb(int HWIndex, int port, int sig, void *arg)
{
    printf("input_get_cb() HWIndex %d port %d sig %d\n", HWIndex, port, sig);
    return 0;
}
static int

```



```

output_set_cb(int HWIndex, int port, int last_sig, void *arg)
{
    printf("output_set_cb() HWIndex %d port %d last sig %d\n", HWIndex, port,
last_sig);
    last_sig++;
    last_sig %= 2;
    printf("new sig=%d\n", last_sig);
    return last_sig;
}
static int
output_get_cb(int HWIndex, int port, int sig, void *arg)
{
    printf("output_get_cb() HWIndex %d port %d sig %d\n", HWIndex, port, sig);
    return 0;
}
#define INTERVAL      10000
int
#ifdef(_WIN32_WCE)
WINAPI
WinMain( HINSTANCE hInstance, HINSTANCE hPrevInstance, LPTSTR lpCmdLine, int
nCmdShow )
#else
main(int argc, char *argv[])
#endif
{
    DGIOMNGR *mngnr;
    int HWIndex;
    int port;
    int interval;
#ifdef(_WIN32_WCE)
    int  argc;
    char cmdline[256], *argv[32];
    WideCharToMultiByte(CP_ACP, 0, (LPCTSTR)lpCmdLine, 255, cmdline, 256, NULL,
NULL);
    argc = split_line(argv+1, 32, cmdline)+1;
#endif
    if (argc > 1) interval = atoi(argv[1]);
    else interval = INTERVAL;
    mngnr = digit_io_timer_init();
    if (mngnr == NULL) {
        printf("digit_io_timer_init() error\n");
        return -1;
    }
    HWIndex=0; // HWIndex=0 for embedded DIO
    for (port = 0; port < 1; port++) {
        if (digit_io_timer_add_callback(mngnr, HWIndex, port,
DGTIO_GET_INPUT_STATE_CHANGE, interval, input_chg_cb, &port) < 0) {
            printf("add %d input change callback error\n", port);
            return -2;
        }
        if (digit_io_timer_add_callback(mngnr, HWIndex, port, DGTIO_GET_INPUT,
interval, input_get_cb, &port) < 0) {
            printf("add %d input callback error\n", port);
            return -3;
        }
    }
}

```

```

if (digit_io_timer_add_callback(mngr, HWIndex, port, DGTIO_SET_OUTPUT, interval,
output_set_cb, &port) < 0) {
    printf("add %d set output callback error\n", port);
    return -4;
}
if (digit_io_timer_add_callback(mngr, HWIndex, port, DGTIO_GET_OUTPUT, interval,
output_get_cb, &port) < 0) {
    printf("add %d get output callback error\n", port);
    return -5;
}
}
// HWIndex=1 for EPM-3438 board #1; HWIndex=2, for EPM-3438 board #2
for (HWIndex = 0; HWIndex < HW_TOTAL; HWIndex++) {
    for (port = 0; port < 8; port++) {
        /* since list is LIFO last callbacks are added first */
if (digit_io_timer_add_callback(mngr, HWIndex, port, DGTIO_GET_INPUT_STATE_CHANGE,
interval, input_chg_cb, &port) < 0) {
            printf("add %d input change callback error\n", port);
            return -2;
        }
if (digit_io_timer_add_callback(mngr, HWIndex, port, DGTIO_GET_INPUT, interval,
input_get_cb, &port) < 0) {
            printf("add %d input callback error\n", port);
            return -3;
        }
if (digit_io_timer_add_callback(mngr, HWIndex, port, DGTIO_SET_OUTPUT, interval,
output_set_cb, &port) < 0) {
            printf("add %d set output callback error\n", port);
            return -4;
        }
if (digit_io_timer_add_callback(mngr, HWIndex, port, DGTIO_GET_OUTPUT, interval,
output_get_cb, &port) < 0) {
            printf("add %d get output callback error\n", port);
            return -5;
        }
    }
}
digit_io_timer_dispatch(mngr);
return 0;
}

```

### Example 3: Read the EPM-3438 counter value and clear the counter

File and Folder: /example/V2100.V24XX/EPM3438/digit\_input\_change/**tcounter.c**

```

#include <stdio.h>
#include <stdlib.h>
#include <sys/time.h>
#include <fcntl.h>
#include <unistd.h>
#include <signal.h>
#include "mxdgio.h" // For counter reading or clear
#define COUNTER_NODE1 "/dev/epm_3438_counter1" // The first EPM-3438
#define COUNTER_NODE2 "/dev/epm_3438_counter2" // The second EPM-3438
int main(int argc, char * argv[])

```

```

{
    int retval;
    int fd, fd2, len;
    unsigned int counter_value;
    fd=open(COUNTER_NODE1, O_RDONLY);
    while( 1 ) {
        printf("\nSelect a number of menu, other key to exit.  \n\
1. Get counter value                \n\
2. Clear the counter                 \n\
Others. quit                          \n\
Choose : ");
        scanf("%d", &retval);
        if ( retval == 1 ) { // Get counter without reset
            counter_value = mxdbgio_epm3438_get_counter(fd);
            printf("EPM-3438 board #1 counter:%d\n", counter_value);
        }
        else if ( retval == 2 ) { // Get counter with reset
            retval = mxdbgio_epm3438_clear_counter(fd);
            if ( retval < 0 )
                printf("EPM-3438 board #1 counter reset fail\n");
        }
        else {
            break;
        }
    }
    close(fd);
    return 0;
}

```

## EPM-3337 Driver Installation

Moxa's EPM-3337 module supports 3G, GPS, and Wi-Fi. This section introduces how to configure these functions in the Linux platform.

The EPM-3337 driver operates in two modes: Linux and Windows. The default is Windows mode. During this process, the user will run a script that will reset the driver from Windows mode to Linux mode.

1. Remount the root file system read-write:

```
Moxa:~# mount -o remount,rw /
```

2. Use dpkg to install the Debian package, **epm3337.deb**. This package file installs the driver and a few scripts to configure the initialization process. **epm3337.deb** is not available on your software CD; you must download it from the Moxa website

at: <http://www.moxa.com/support/download.aspx?type=support&id=1799>.

```
Moxa:/home# dpkg -i epm3337.deb
```

3. Moxa provides an automated shell script to perform the initial set up of the EPM-3337 module, to configure the initialization process and set the EPM-3337 to Linux mode. After installing **epm3337.deb**, the **moxa\_hc25\_setup\_mdm.sh** script should have been automatically installed in the **/home** directory. This script only needs to be run once.

```
Moxa:/home# sh moxa_hc25_setup_mdm.sh
```

4. To see if the the kernel module is properly loaded and set up you should use the Debian **lsusb** command. This will list the vendor and product IDs for all USB devices; the Sierra Wireless MC8305 HSPA card will show one of either two IDs, depending on how it is set up. **MDMNet mode** is the default, and is used for Windows, **MDM mode** is for Linux. Your device should be displaying the Linux ID:

- USB Device ID: 0681:0040 – Windows mode (**MDMNet mode**, default factory setting)
- USB Device ID: 0681:0047 - for Linux (**MDM mode**)

Confirm that the installation has been successful and your card is accessible by querying the USB bus, as below:

```
Moxa:/home# lsusb
Bus 001 Device 010: ID 0681:0047 Siemens Information and Communication
```

5. To allow the driver to load at startup you first need to alter the **RC** entry in the appropriate **runlevel commands** directories. These are directories of symbolic links arranged by runlevel that point to the initialization files located in /etc/init.d. To enable the file to be loaded at boot time, change the first letter in the name of the symbolic link pointing to the EPM-3337 initialization file from **N** (igNore) to **S** (Start). The default runlevel for the V24XX series computers is 2. To change the file name of the symbolic link, navigate to /etc/rc2.d and issue the following command (this reboots the system to load the module):

```
Moxa:~# cd /etc/rc2.d
Moxa:/etc/rc2.d# mv N98moxa_hc25_load_driver S98moxa_hc25_load_driver & reboot
```

6. To get full wireless capabilities, you will also need to install software packages from an official Debian repository; this will likely require an internet connection.

If you do not wish to expose the computer to the open Internet, then you may prepare a software CD in advance and use that, instead. This will require an alteration of your apt.source list, however. For more information on how to do this, consult this web page:

<http://answers.oreilly.com/topic/19-how-to-install-debian-packages-from-cd-rom/>

If you have not altered your apt.sources list and are connected to the Internet, then you should be able to issue the commands below and automatically download the latest versions.

```
Moxa:/home# apt-get install wpa_supplicant wireless-tools
```

7. To enable create the correct links for wpa\_supplicant

```
Moxa:/etc/network/if-up.d# ln -sf /etc/wpa_supplicant/ifupdown.sh wpa_supplicant;
ln -sf /etc/wpa_supplicant/ifupdown.sh wpa_supplicant;
ln -sf /etc/wpa_supplicant/ifupdown.sh wpa_supplicant;
ln -sf /etc/wpa_supplicant/ifupdown.sh wpa_supplicant
```

8. Now remount the root file system (/) read-only using the umount command, and reboot your device to complete the installation.

```
Moxa:~# umount /; reboot
```



## ATTENTION

The PPP v2.4.4 sometimes connects to the incorrect DNS; here are two workarounds:

1. **Assign the DNS server manually:** Comment out `usepeerdns` from `/dev/pppt/chtgprs`. Then assign a DNS manually, in `/etc/resolv.conf`.
2. Use apt-get to remove **ppp 2.4.4** and install **ppp-2.4.5.deb**

```
Moxa:~# apt-get remove ppp
Moxa:/home# dpkg -i ppp-2.4.5.deb
```

## EPM-3337: Operating Modes

The EPM-3337 module has two operating modes, **Normal** and **Multiplex**:

**Normal Mode** Supports GPRS/HSDPA, but no GPS. The ports are allocated as follows:

- Modem port: `/dev/ttyACM0`
- Command port: `/dev/ttyUSB0`

**Multiplexer Mode** supports GPRS/HSDPA and GPS. A multiplexer program must be run to put the module into multiplexer mode. The ports are allocated as:

- Modem port: `/dev/pts/0`

- Command port: `/dev/pts/1`
- GPS port: `/dev/pts/2`

**ATTENTION!**

If two EPM-3337 modules are being used, set `module_num=2` in the EPM-3337 initialization script, found at `/etc/init.d/moxa_hc25_mux_script`.

**WARNING!**

If GPS functionality is not needed, normal mode will give better performance.

## EPM-3337: Normal Mode—GPRS/HSDPA

This section illustrates how to establish a point-to-point connection using `pppd`. The example files used are:

- `/etc/ppp/peers/chtgprs`: the GPRS options file for chat
- `/etc/chatscripts/chtgprs-connect`: chat connections file
- `/etc/chatscripts/chtgprs-disconnect`: chat disconnection file

To set up GPRS using `pppd`:

1. Configure the file `/etc/ppp/peers/chtgprs`.
  - a. First, check if the name of the modem port is correct. It should be `/dev/ttyACM0` for the first module, `/dev/ttyACM1` for the second one, and so on.
  - b. Make sure the **local** option is enabled. This option ignores the CD (Carrier Detect) signal.
2. Configure `/etc/chatscripts/chtgprs-connect`. For all AT commands, all options should be separated by a comma, and all strings must be enclosed in double quotations.
  - a. First, check the **packet data protocol type** and **Access point name** of the ISP;
 

A basic command would be `AT+CGDCONT=1, <PDP_type>, <APN>`. If your PDP type and APN were (respectively) **IP** and **Internet**, the above command would be written:

```
AT+CGDCONT=1, "IP", "Internet"
```
  - b. Check the ATD dialout number: `ATD <number>`
  - c. Connect using the configuration files: `pppd call chtgprs`
3. Finally, confirm your configuration is correct by validating the connection state using `ifconfig ppp0`. If the connection is ok, `ifconfig` will show an extended description of all internal data about the `ppp0` (or `pppn`) interface.

## EPM-3337: Multiplexer Mode: GPS + GPRS/HSDPA

GPS functionality can only be enabled when the module is set for multiplexer mode. In multiplexer mode, the system uses a pseudo-terminal slave (`pts`) instead of reading serial ports (`/dev/ttyACMx`) to communicate.

To enable multiplexer mode, you must change the `pppd` configuration file found in the PPPd configuration folder at `/etc/ppp/peers` by changing the **modem port used** entry to `/dev/pts/0`. This should be the first line in your configuration file following the title. Simply comment out the `/dev/ttyACM0` entry and on the next line add the following line (as shown in the full peers file, displayed below):

```
/dev/pts/0 # modem port used
```

```
# File: /etc/ppp/peers/chtgprs
# See /etc/ppp/options for detail

#/dev/ttyACM0 # modem port used
/dev/pts/0 # modem port used
```

```

115200      # speed
defaultroute # use the cellular network for the default route
noipdefault
usepeerdns  # use the DNS servers from the remote network
#nodetach   # keep pppd in the foreground
nocrtscts   # hardware flow control
lock        # lock the serial port
noauth      # don't expect the modem to authenticate itself
persist     # if a connection terminated, try to reopen
#demand

#Carrier Detect or Data Terminal Ready,
#choose modem(default) or local(ignore)

#modem
local

#Debug option---
#You call tail -f /var/ppp.log &
#debug
#logfile /var/ppp.log

# Use the next two lines if you receive the dreaded messages:
#
#   No response to n echo-requests
#   Serial link appears to be disconnected.
#   Connection terminated.
#
lcp-echo-failure 4
lcp-echo-interval 65535

#add -V for debug
connect  "/usr/sbin/chat -v -f /etc/chatscripts/chtgprs-connect"
disconnect "/usr/sbin/chat -v -f /etc/chatscripts/chtgprs-disconnect"

```

The following steps illustrate how to set up GPS and use gpsd.

1. Set the module to enter multiplexer mode at startup by setting the initialization script, found in /etc/rc2.d, to run at boot time.

```
Moxa:/etc/rc2.d# mv N99moxa_hc25_mux_script S99moxa_hc25_mux_script
```

2. Reboot and the script will switch the modem to run in multiplexor mode.



### ATTENTION

The number assigned to the pseudo-terminals (pts) is affected by remote logins (e.g., ssh, or telnet). The moxa\_hc25\_mux is run at startup to make sure the pseudo-terminals are generated as pts/0, ~/1, ~/2, etc, so that remote logins will not interfere with your GPS connections.



### WARNING

If you have previously configured the EPM-3337 for normal mode, be sure to return the runlevel command /etc/rc2.d/S98moxa\_hc25\_load\_driver back to /etc/rc2.d/N98moxa\_hc25\_load\_driver.

3. Reboot the computer.
4. The multiplexer will now automatically start at bootup and will be associated with the modem port `/dev/ttyACM0`; it will generate three virtual terminal ports.

- `/dev/pts/0`: Modem port
- `/dev/pts/1`: Command port
- `/dev/pts/2`: GPS port

If you have a second EPM-3337 module, the allocation will be:

- `/dev/pts/3`: Modem port 2
- `/dev/pts/4`: Command port 2
- `/dev/pts/5`: GPS port 2



### ATTENTION

When in multiplexer mode the serial terminal will only accept AT commands that end with `\r\n` (i.e., *carriage return+newline*). However, it is possible to set the serial emulator to automatically translate simple *carriage return* symbols (`\r`) to *carriage return+newline* (`\r\n`).

To enable automatic translation of *carriage return* (`\r`) to *carriage return+newline* (`\r\n`), you may reset the terminal output flag with this command:

```
Moxa~#: stty -F /dev/pts/1 opost onlcr.
```

The tag **onlcr** will allow the serial terminal to automatically translate `\r` to `\r\n`. You can see the translation at work in step 4, just below this note.

5. Enable the GPS port:

```
Moxa:~# cat < /dev/pts/1 & echo -e "AT^SGPSS=4\r" > /dev/pts/1
```

You may cancel the above command by using

```
Moxa:~#killall cat, or <ctrl>+C
```

6. Verify you are receiving NMEA data from the GPS port `/dev/pts/2`:

```
Moxa:~# cat < /dev/pts/2
$GPGSV,1,1,04,24,28,123,37,21,09,054,31,19,52,213,,23,47,270,*74
$GPGGA,061824.0,2458.835139,N,12133.055835,E,1,05,19.7,-103.5,M,,,*14
$GPRMC,061824.0,A,2458.835139,N,12133.055835,E,,290710,,*A*68
$GPGSA,A,3,24,21,06,31,16,,,,,,,,,25.5,19.7,18.5*29
$GPVTG,,T,,M,0.0,N,0.0,K*4E
```

7. Install the GPS daemon:

```
Moxa:~# apt-get install gpsd
```

8. Start `gpsd` to begin reading NMEA data from the GPS command port (`/dev/pts/2`):

```
Moxa:~# gpsd /dev/pts/2
```

9. For remote connections, you may use **ssh** to connect and issue the `cgps` command. If `cgps` is properly set up, it will display the following information (screen shot at top of next page):

```

Time:      2010-07-29T06:46:38.0Z
Latitude:  24.980836 N
Longitude: 121.552724 E
Altitude:  107.5 M
Speed:     n/a
Heading:   n/a
Climb:     0.0 M/Min
Status:    3D FIX (13 secs)
GPS Type:  Generic NMEA
Horizontal Err: +/- 131 M
Vertical Err: +/- 78 M
Course Err: n/a
Speed Err: +/- 973 kph

PRN:  Elev:  Azim:  SNR:  Used:
 11   04    201    00    N
 7    11    319    00    N
 13   37    288    13    N
 24   35    108    43    Y
 21   05    045    27    N
 19   65    227    00    N
 3    75    350    25    Y
 23   44    250    00    N
 6    61    026    38    Y
 31   18    127    25    Y
 16   37    042    40    Y

0.000 0.000 ? 310.40 ? 3
GPRMC,0.00,A,24.980836,N,121.552725,E,0.0,0.0,0.0,128.0,0.0,0.0,0.0,0.0,0.0
0.000 0.000 ? 280.00 ? 3

```

To stop the GPS module from transmitting, send

```
AT^SGPSS=0
```

to the command port. The following code will allow you to monitor the cutoff of the signal. Use

```
Moxa:~#killall cat
```

to close the live display of the device data.

```

Moxa:~# cat < /dev/pts/1 &
Moxa:~# echo -e "AT^SGPSS=0\r" > /dev/pts/1
Moxa:~# killall cat

```



## ATTENTION

For more information about gpsd the following references are available online:

- The GPSD Unix manual page: <http://gpsd.berlios.de/gpsd.html>
- The GPSD project website: <http://catb.org/gpsd/>
- The GPSD coder's website, at Savannah: <https://savannah.nongnu.org/projects/gpsd/>
- The CGPS Unix manual page: <http://www.pkill.info/linux/man/1-cgps/>
- The Debian User Forums: <http://forums.debian.net/>
- The Debian Administrator's Handbook: <http://debian-handbook.info/browse/stable/>

As described in this section, in multiplex mode the modem port is `/dev/pts/0` instead of `/dev/ttyACM0`. Check that the modem port is `/dev/pts/0` at `/etc/ppp/peers/chtgprs`.

```

# See /etc/ppp/options for details
/dev/pts/0 # modem port used
115200    # speed

```

Now you can connect GPRS/HSDPA through pppd

```
Moxa:~# pppd call chtgprs
```

## EPM-3337: Troubleshooting PPPD

To troubleshoot pppd problems, first put the daemon into debug mode by opening `/etc/ppp/peers/chtgprs` and taking the steps on the page following:

- First activate the **debug** mode and start writing to the **logfile** (`/var/ppp.log`) by un-commenting the options; this is done by deleting the pound sign (**#**) at the front of the line.
- Make the logfile verbose by adding the `-v` option to the `/usr/sbin/chat` command.



```
#Debug option---
#You call tail -f /var/ppp.log &
debug
logfile /var/ppp.log
connect "/usr/sbin/chat -v -V -f /etc/chatscripts/chtgprs-connect"
```

Now, `/var/ppp.log` will return much more detailed debugging messages.

## EPM-3337: Setting up a Wi-Fi Connection

In this section we show you how to connect to an 802.11 access point using WPA2 (RSN). The connection program we will use is **wpa\_supplicant**.

The basic command to connect for WPA-suppllicant is:

```
Moxa:~# wpa_supplicant -i <interface> -c <configuration file> -B
```

The **-B** option should be included because it forces the supplicant to run in the background.

### Example 1: Connect to an AP using WEP



#### WARNING

**Moxa strongly advises against the use of the WEP and WPA encryption standards.** Both are now officially deprecated by the Wi-Fi Alliance, and are considered insecure. To guarantee proper Wi-Fi encryption and security, please use WPA2 with the AES encryption algorithm.

The SSID for this hypothetical network is `test_wep`, and the WEP encryption key is 1234567890 (hexadecimal).

- A. First, create a WEP configuration file; write the sample below as `/etc/wpa_supplicant/test_wep.conf`:

```
network={
    ssid="test_wep"
    key_mgmt=NONE
    wep_key0=1234567890
    wep_key1="abcde"
    wep_key2="1234567890123"
    wep_tx_keyidx=0
    priority=5 }
```

- B. Connect with the following command. If you are in the `wpa_supplicant` directory, then:
 

```
Moxa:~# wpa_supplicant -i wlan0 -c test_wep.conf -B
```
- C. Use **iwconfig** to check the connection state. This will return something close to the following:

```
wlan0 IEEE 802.11abgn ESSID:"test_wep"
Mode:Managed Frequency:2.462 GHz Access Point: 00:1F:1F:8C:0F:64
Bit Rate=36 Mb/s Tx-Power=27 dBm
Retry min limit:7 RTS thr:off Fragment thr:off
Encryption key:1234-5678-90 Security mode:open
Power Management:off
Link Quality=37/70 Signal level=-73 dBm
Rx invalid nwid:0 Rx invalid crypt:0 Rx invalid frag:0
Tx excessive retries:0 Invalid misc:0 Missed beacon:0
```

## Example 2: Connect to an AP using WPA



### WARNING

**Moxa strongly advises against the use of the WEP and WPA encryption standards.** Both are now officially deprecated by the Wi-Fi Alliance, and are considered insecure, sub-standard encryption methods. To guarantee proper Wi-Fi encryption and security, please use WPA2 with the AES encryption algorithm.

This hypothetical AP uses `test_wpa` as its **SSID**, and 1234567890 (ascii) as its **WPA key**.

- A. Create the WPA configuration file in the WPA supplicant configuration directory:

```
/etc/wpa_supplicant/test_wpa-wpa2.conf
```

as shown below:

```
network={
    ssid="test_wpa"
    key_mgmt=WPA-PSK
    proto=WPA RSN
    pairwise=TKIP CCMP
    group=TKIP CCMP
    psk="1234567890"
}
```



### ATTENTION

The WPA supplicant configuration file `test_wpa-wpa2.conf` may be used to connect to either WPA or WPA2/RSN encrypted networks, using either the TKIP or CCMP protocol. Using this configuration, when connecting to an access point WPA supplicant will automatically choose the most secure protocol available.

- B. Connect with the following command:

```
Moxa:~# wpa_supplicant -i wlan0 -c test_wpa.conf -B
```

- C. Use `iwconfig` to check the connection state:

```
wlan0 IEEE 802.11abgn ESSID: "test_wpa"
Mode: Managed Frequency: 2.462 GHz
Access Point: 00:1F:1F:8C:0F:64
Bit Rate=36 Mb/s Tx-Power=27 dBm
Retry min limit:7 RTS thr: off Fragment thr: off
Encryption key:
157A-1DBD-B0C3-7CC8-0F9C-D059-2881-F815-E4DB-3705-6969-8253-865E-4
DF0-FDB8-AEC1 [2]
Security mode: open
Power Management: off
Link Quality=34/70 Signal level= -76 dBm
Rx invalid nwid: 0 Rx invalid crypt: 0 Rx invalid frag:0
Tx excessive retries:0 Invalid misc:0 Missed beacon:0
```

## Example 3: Connect to an AP using RSN (WPA2)

This hypothetical AP uses `test_wpa2` as its **SSID**, and **1234567890** (ascii) as its **WPA key**.

- A. Create the configuration file `test_wpa-wpa2.conf`, [as described in the section just above](#).

- B. Use `iwconfig wlan0` to view details about the connection configuration.

```
wlan0 IEEE 802.11abgn ESSID:"test_wpa2"
Mode:Managed Frequency:2.462 GHz
Access Point: 00:1F:1F:8C:0F:64
Bit Rate=1 Mb/s Tx-Power=27 dBm
Retry min limit:7 RTS thr:off Fragment thr:off
Encryption key: 8546-8201-6DCA-8A37-6EE6-AD44-8D3F-6553 [2]
```

**ATTENTION**

Here are some references for more information about WPA Supplicant:

The official homepage for WPA Supplicant: [http://hostap.epitest.fi/wpa\\_supplicant/](http://hostap.epitest.fi/wpa_supplicant/)

The configuration

README: [http://hostap.epitest.fi/gitweb/gitweb.cgi?p=hostap.git;a=blob\\_plain;f=wpa\\_supplicant/README](http://hostap.epitest.fi/gitweb/gitweb.cgi?p=hostap.git;a=blob_plain;f=wpa_supplicant/README)

Wi-Fi Configuration Using WPA and WEP:

[http://www.gnx.com/developers/docs/6.4.1/io-pkt\\_en/user\\_guide/wpa\\_background.html](http://www.gnx.com/developers/docs/6.4.1/io-pkt_en/user_guide/wpa_background.html)

ExampleNow page showing WPA Supplicant configuration and usage examples:

[http://www.exemplenow.com/wpa\\_supplicant/](http://www.exemplenow.com/wpa_supplicant/)

## EPM-3337: Getting Wireless Card Information

The program `iw` is a Linux configuration utility for wireless devices that can acquire more complete information than `iwconfig`. Although still under development, it contains some useful functionality.

To get connection data, issue the command

```
Moxa:~# iw dev <interface> station dump:
```

```
Moxa:~# iw dev wlan0 station dump
Station 00:1f:1f:8c:0f:64 (on wlan1)
    inactive time: 35696 ms
    rx bytes:      98054
    rx packets:    364
    tx bytes:      733
    tx packets:    7
    signal:        -75 dBm
    tx bitrate:    MCS 42 40Mhz
```

**ATTENTION**

More information about the `iw` utility may be found here:.

<http://linuxwireless.org/en/users/Documentation/iw/>

## EPM-3112: CAN Bus Interface

The EPM-3112 module provides V24XX series computers with a CAN bus interface. CAN is a broadcast serial bus standard for connecting electronic control units (ECUs). Each node is able to send and receive messages, but not simultaneously: a message (consisting primarily of an ID—usually chosen to identify the message-type/sender—and up to eight message bytes) is transmitted serially onto the bus, one bit after another. This signal-pattern codes the message (in NRZ) and is sensed by all nodes.

The Moxa EPM-3112 module provides the CAN bus interface for industrial CAN communication. Users can use Moxa's CAN library or the local GNU/Linux device control interface (`ioctl`) to program reads, writes, and controls for CAN devices.

### EPM-3112: Driver Installation

CAN is a serial bus protocol for connecting and controlling electronic devices in harsh environments. A CAN bus connects electronic control units (ECUs) so that each node may send and receive messages that consist of an ID (to identify the message-type and sender) and up to eight message bytes.

Moxa EPM-3112 module provides a CAN bus for industrial CAN communication. You may use Moxa's CAN library or the local GNU/Linux device control interface (ioctl) to program reads, writes, and controls for CAN devices. To install the EPM-3112 kernel module:

1. Make the root file system writable:

```
Moxa:~# mount -o remount,rw /
```

2. Use the `dpkg` installer to install the `epm3112.deb` package. This package will automatically enable your EPM-3112 module to load at boot time:

```
Moxa:/home# dpkg -i epm3112.deb
```

3. Re-mount the root system read-only:

```
Moxa:~# umount /
```

4. Then `modprobe` the module, `moxa_can`, or reboot your device to finish this installation.

## EPM-3112: Programming Guide

### Moxa's CAN Library

Moxa's CAN programming library, `mxcanbus_1x.c`, is an open-source CAN bus library. The commands for `mxcanbus_1x.c` are documented in the following tables.

#### Moxa CAN Functions

|             |  |
|-------------|--|
| Function    | <b>unsigned int mxcan_get_bus_timing (unsigned int fd)</b> |
| Description | Get the bus timing of an open port.                        |
| Input       | <fd> open file handle                                      |
| Output      | None   |
| Return      | 0 on failure, otherwise the bus speed in KHz               |

|             |  |
|-------------|--|
| Function    | <b>int mxcan_get_parameters (unsigned int fd, CANPRM *param)</b> |
| Description | Return the parameters of an open port.                           |
| Input       | <fd> open file handle  |
| Output      | <param> pointer to a structure of CANPRM                         |
| Return      | 0 on success. Otherwise return a negative value                  |

|             |   |
|-------------|---|
| Function    | <b>int mxcan_get_registers (unsigned int fd, unsigned char *buffer, int num)</b>                                |
| Description | Return the register values of an open port.   |
| Input       | <fd> open file handle<br><num> number of register values. For module with sja1000 chipset, the value must be 32 |
| Output      | <buffer> point to a buffer for these values   |
| Return      | 0 on success, otherwise failure   |

|             |   |
|-------------|---|
| Function    | <b>int mxcan_get_stat (unsigned int fd, CANBST *stat)</b> |
| Description | Return the statistics of an open port.                    |
| Input       | <fd> open file handle                                     |
| Output      | <stat> point to a container of statistics                 |
| Return      | 0 on success, otherwise failure                           |

|             |  |
|-------------|--|
| Function    | <b>int mxcan_inqueue (unsigned int fd)</b>                   |
| Description | Return the number of received bytes queued for an open port. |
| Input       | <fd> open file handle  |
| Output      | None   |

|        |                                     |
|--------|-------------------------------------|
| Return | < 0 on failure, the number of bytes |
|--------|-------------------------------------|

|             |  |
|-------------|--|
| Function    | <b>unsigned int mxcan_open (int port)</b>  |
| Description | Open a CAN port using its local GNU/Linux device node ID                         |
| Input       | <port> port number starting from 1. In Linux, port 1 will be opened as /dev/can0 |
| Output      | None   |
| Return      | 0 on failure, otherwise return fd  |

|             |   |
|-------------|---|
| Function    | <b>int mxcan_outqueue (unsigned int fd)</b>                         |
| Description | Return the number of bytes an open port has queued for transmission |
| Input       | <fd> open file handle   |
| Output      | None  |
| Return      | < 0 on failure, the number of bytes                                 |

|             |   |
|-------------|---|
| Function    | <b>int mxcan_purge_buffer (unsigned int fd, unsigned int purge)</b>                               |
| Description | Purge an open port's buffers  |
| Input       | <fd> open file handle<br><purge> 1: receive data buffer, 2: transmit data buffer, otherwise: both |
| Output      | None  |
| Return      | 0 on success, otherwise failure   |

|             |   |
|-------------|---|
| Function    | <b>int mxcan_set_bus_timing (unsigned int fd, unsigned int speed)</b>   |
| Description | Set the bus timing for an open port.  |
| Input       | <fd> open file handle<br><speed> bus timing in KHz. The available values are<br>5/10/20/40/50/80/100/125/200/250/400/500/666/800/1000 |
| Output      | None  |
| Return      | 0 on success, otherwise returns a negative value  |

|             |  |
|-------------|--|
| Function    | <b>int mxcan_set_nonblocking (unsigned int fd)</b> |
| Description | Set an open file handle ID to be non-blocking.     |
| Input       | <fd> open file handle                              |
| Output      | None   |
| Return      | 0 on success, otherwise returns a negative value   |

|             |   |
|-------------|---|
| Function    | <b>int mxcan_set_parameters (unsigned int fd, CANPRM *param)</b>  |
| Description | Set the parameters for an open port.                              |
| Input       | <fd> open file handle<br><param> pointer to a structure of CANPRM |
| Output      | None  |
| Return      | 0 on success, otherwise return a negative value                   |

### Moxa definitions for CAN bus Macros

```
#define mxcan_close(fd)          close((int)fd)
#define mxcan_read(fd, buffer, size, hndl)  read((int)fd, buffer, size)
#define mxcan_write(fd, buffer, size, hndl) write((int)fd, buffer, size)
```

### Moxa's CAN Library: Sample Code

You may download the entire mxCAN bus library and sample code from the MOXA website.

[http://www.moxa.com/support/support\\_home.aspx](http://www.moxa.com/support/support_home.aspx)

## EPM-3552: Driver Installation

The Moxa EPM-3552 module provides VGA and DVI video display for Moxa's V2422 and V2426 computers.

1. Make the root file system writable.

```
Moxa:~# mount -o remount,rw /
```

2. Install the package **epm3552.deb**. The EPM-3552 Debian software package is not available on your software CD. It must be downloaded from the Moxa website, and may be found at <http://www.moxa.com/support/download.aspx?type=support&id=1799>.

```
Moxa:/home# dpkg -i epm3552.deb
```

3. Install the **gconf-editor**. This is available using standard Debian repositories available on the Internet.

```
Moxa:~# apt-get install gconf-editor
```

4. Install **grandr**.

```
Moxa:~# apt-get install grandr
```

5. Start the GNOME desktop environment.

```
Moxa:~#/etc/init.d/gdm stop; /etc/init.d/gdm start
```

6. Disable the **xrandr** plug-in, because the **gnome-settings-daemon** gives poor x-rander support. In gnome, launch **Applications** → **System Tools** → **Configuration Editor**, and then cancel **xrandr active options**; you will find it in **/apps/gnome\_settings\_daemon/plugins/xrandr/**.

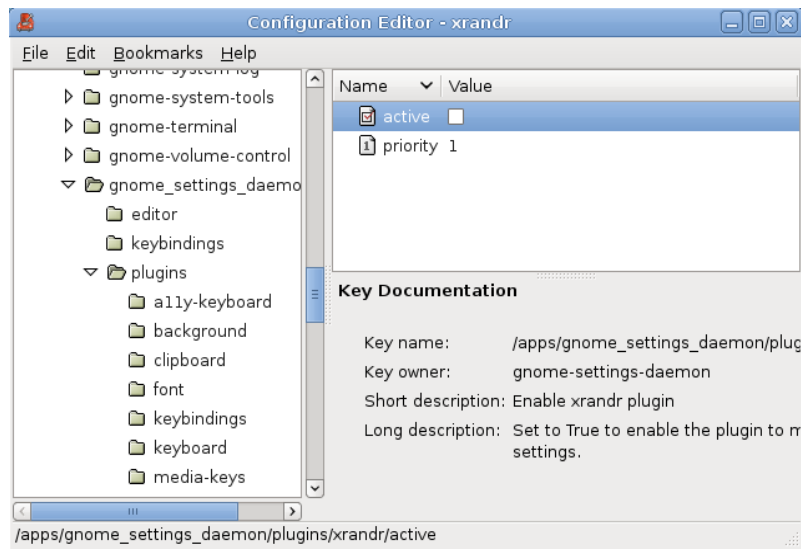

7. Re-mount the root file system as read-only.

```
Moxa:~# umount /
```

## EPM-3552: Configuring the X Server

The V2422 and V2426 computers already support VGA and DVI display output, so this section illustrates how to configure EPM-3552 to display a single desktop across dual monitors that are run out of the EPM-3552's DVI and VGA ports.

This configuration was successfully tested with two 18" and two 22" monitors sharing the same aspect ratio.

1. Connect your monitors to the EPM-3552 module before booting the computer.
2. After booting up, first **back up the local interface's configuration file**, which is located at **/etc/X11/xorg.conf**.

```
Moxa:~#cp /etc/X11/xorg.conf /etc/X11/xorg.conf.BAK
```

3. Next, rename the new configuration file **xorg.conf-epm3552-dual** to **xorg.conf**. This file should have been installed with the Debian package file you installed in step 2, above.

```
Moxa:~#cp /etc/X11/xorg.conf-epm3552-dual /etc/X11/xorg.conf
```

4. Now, you may edit the new XOrg display configuration using your preferred text editor. For the built-in Intel chipset, the only thing you should need to configure is the screen size. The value **3840x1080** is the

maximum resolution (**1920 x1080** x 2) of a desktop shared across two monitors. This is possible by configuring the EPM-3552's VGA and DVI interfaces to extend a display across both interfaces.

```
Section "Screen"
    Identifier      "Screen_Intel"
    Device          "Device_Intel"
    Monitor         "VGA"
    SubSection "Display"
        Depth      24
        Virtual     3840 1080
    EndSubSection
EndSection
```

5. Set up the initial mode of the built-in VGA/DVI ports. The default value is the maximum resolution of the monitor; you can adjust it in `/etc/X11/Xsession.d/45xrandr`.

- a. To display an extended desktop use the configuration below:

```
#Resolution
res=1920x1080
#Extended mode
xrandr --output TMDS-1 --mode $res --right-of VGA --output VGA --mode $res
#Clone mode
```

- b. To display a cloned desktop use the configuration below:

```
#Resolution
res=1920x1080
#Extended mode
#xrandr --output TMDS-1 --mode $res --right-of VGA --output VGA --mode $res
#Clone mode
xrandr --output TMDS-1 --mode $res --same as VGA --output VGA --mode $res
xrandr --output TMDS-1 --mode $res --same-as VGA --output VGA --mode $res
```

The tags are explained below:

**output:** Defines which interface the XRandR settings will apply to; DVI is **TMDS-1**, **VGA** is for VGA

**right-of:** Defines the relative position of the interface in the extended desktop

**same-as:** Sets clone mode

**mode:** Sets the screen resolution

6. Next start the X server:

```
Moxa: ~#/etc/init.d/gdm start
```

## EPM-3552: Enabling a Dual Screen Display

To use two EPM3552 modules side-by-side you must first enable the second module by uncommenting the settings found under the **Device\_DL2**, **Monitor\_DL2**, and **Screen\_DL2** sections in your new **xorg.conf** (formerly **xorg.conf-epm3552-dual**) in the `/etc/X11` directory. You must also uncomment the **Screen 2** option in the **Server Layout** section. You may review the sample file provided below for more details.

```
#Setting for the second EPM3552 module
Section "Device"
    Identifier      "Device_DL2"
    driver          "displaylink"
    Option          "fbdev" "/dev/fb1"
EndSection

Section "Monitor"
    Identifier      "Monitor_DL2"
EndSection

Section "Screen"
```

```

Identifier      "Screen_DL2"
Device         "Device_DL2"
Monitor        "Monitor_DL2"
SubSection    "Display"
    Depth      24
EndSubSection
EndSection

Section "ServerLayout"
Identifier      "945G-Layout"
Screen 0 "Screen_Intel" 0 0
Screen 1 "Screen_DL1" LeftOf "Screen_Intel"
Screen 2 "Screen_DL2" LeftOf "Screen_DL1"
InputDevice    "Generic Keyboard" "CoreKeyboard"
InputDevice    "Configured Mouse" "CorePointer"
EndSection

```

When finished, connect a monitor to the second EPM-3552 module and reboot your system to activate the settings.

**NOTE** For Linux systems, due to the limitations of the Linux RandR design the EPM-3552 display module cannot be extended or mirrored across the V2422/V2426 computers' built in VGA/DVI-I display interfaces. Likewise, When using the EPM-3552 display module the display may not be mirrored or extended across the built-in interfaces, either. When using the EPM-3552 display module, it is only possible to use one of the V24XX series' built-in display interfaces a single, independent, standalone display.

## EPM-3552: Configuring a Single Display

Back up your `/etc/X11/xorg.conf` file and then rename `xorg.conf-epm3552-single` to `xorg.conf` (see [the section above](#), on chipset configuration, if you need to review the commands). Next, start the X window to launch a solitary display only on the EPM-3552 module.

## EPM-3552: Dynamically Changing the Display Resolution

In this section we explain how to temporarily change the resolution and mode. To change the settings permanently, modify the file `/etc/X11/Xsession.d/45xrandr`. For the EPM-3552 module, only the current driver can display the maximum resolution of a connected monitor. Therefore, even the "Modes" Option in `xorg.conf` cannot adjust its resolution. For the built-in VGA/DVI port driven by an Intel chipset, use X RandR or **G RandR**, located in **System** → **Administration** → **Multiple Screens**, to change the layout and resolution.

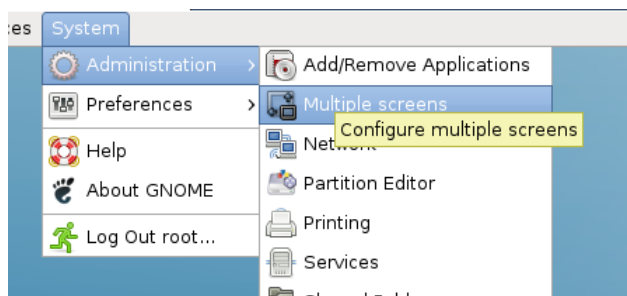

**NOTE** Whenever you test new X RandR settings—such as when you adjust the resolution—the display will be reset to cloned displays. So when using extended displays, whenever you have changed and tested a new setting make sure to first **re-set the display to Extended Mode** before applying the settings and exiting the interface.



**ATTENTION**

1. To make sure the kernel module loads properly, be sure to connect the monitor to the EPM-3552 module before booting up the computer.
2. The built-in VGA/DVI port only supports clone and extended mode; dual head mode is not supported.
3. The X RandR project homepage may be found here:  
<http://www.x.org/wiki/Projects/XRandR>
4. Click the following link for more information on Xorg configuration: <https://wiki.ubuntu.com/X/Config/Resolution>
5. For the X RandR Unix manual page (i.e., man page), check here:  
[http://www.thinkwiki.org/wiki/Xorg\\_RandR\\_1.2](http://www.thinkwiki.org/wiki/Xorg_RandR_1.2)

## EPM-DK02: Driver Installation

Moxa's EPM-DK02 module supports 2 mini PCIe slots for connecting mini PCIe modules.

- **Slot 1: Physical interface:** mini PCIe  
**Electrical interface:** mini PCIe, USB 2.0.
- **Slot 2: Physical interface:** mini PCIe  
**Electrical interface:** USB 2.0.

## EPM-DK02: Installing the Kernel Module

1. Remount the root file system so it is writable:

```
Moxa:~# mount -o remount,rw /
```

2. Use dpkg to install the epmdk02.deb package, found at `EPM-DK02\package\epmdk02.deb`.

```
Moxa:/home# dpkg -i epmdk02.deb
```

3. Mount the root file system (/) as read-only.

```
Moxa:~# umount /
```

4. Load the Moxa EPM-DK02 driver. To do so manually, use the following command:

```
Moxa:~# modprobe moxa_dk02
```

5. To automatically load the module at startup, add the following line into `/etc/rc.local`:

```
Moxa:~# echo 'modprobe moxa_dk02' >> /etc/rc.local
```

## EPM-DK02: Configuring Power Controls

The EPM-DK02 module comes with the capability of automating a modular device's power status. Please be advised, however, that this function is provided primarily for powering on and off a GPRS/HSDPA card that use a USB interface. It is **NOT** advisable to use this function with PCIe devices, because doing so may damage them.

**WARNING**

Use of the EPM-DK02's onboard power controls for control of PCIe or USB-DOM devices is discouraged. Using the onboard power controls for control of PCIe and USB-DOM devices may damage the devices (PCIe) or corrupt data (USB-DOM). **Any use of the EPM-DK02's automated, onboard power controls with PCIe and USB-DOM devices is undertaken at the user's own risk.**

Nor is it advisable to use the power control feature with USB DOM devices, because these devices involve the mounting and unmounting of file systems, and while the Linux system will be able to automatically mount the USB DOM file systems as they come online, without careful scripting it will not be able to automatically unmount the file systems once the device goes offline.

The command for manipulating the PCIe card's power feature is the **mx-dk02** control. The precise syntax is as follows, with **slot\_number** indicating the number of the card slot located on the EPM-DK02 board itself (i.e.: slot\_number does not refer to module slots on the V24XX computer itself):

```
Moxa:~# mx-dk02-control <slot_number> <on/off flag>
```

The on flag is 0, and the off flag is 1..

For example, if you want to power off USB connectivity on slot 1, issue the following command:

```
Moxa:~# mx-dk02-control 1 0
```

Note that the slot number will depend on the position of the interface within the card:

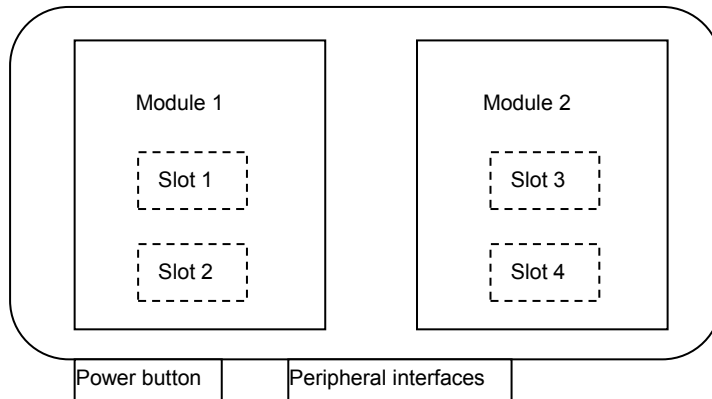
**ATTENTION**

The major aim of the **mx-dk02-control** command is **to reset a USB GPRS/HSPDA module**; it is not advisable to use the power on-off feature with a USB DOM module. This is because when a USB DOM module is powered on, the Linux system will automatically mount its partitions, but when it is powered off the system cannot automatically unmount its partitions.

**Any use of the EPM-DK02's automated, onboard power controls with PCIe interfaces and USB-DOM devices is undertaken at the user's own risk.**

**WARNING**

Note that the power control is only suitable for devices that have a USB interface. If you are using a device with a PCIe interface, do not enable the power on/off control function, since doing so could damage the device.

**Any use of the EPM-DK02's automated, onboard power controls with PCIe interfaces and USB-DOM devices is undertaken at the user's own risk.**

## EPM-DK03: Driver Installation

The EPM-DK03 provides a combination GPS/GPRS card with an extra card slot where a second Wi-Fi, GPS, or GPRS card may be installed. The kernel module for the GPS card bundled with the EPM-DK03 is precompiled into the Linux kernel binary, so there is no need to install another one. The GPS card may be accessed and controlled using the GPS daemon (GPSd), over the ports `/dev/ttyACM0`, or `/dev/ttyACM1` (if a 2nd GPS module is installed). To set up the kernel module:

1. First check if the GPS card is transmitting raw data by issuing the following command to the device node, `/dev/ttyACM0`. If no data is being returned by the card, first try adjusting the GPS antenna to troubleshoot the problem. If there is no way of establishing reception, contact Moxa technical support at the phone number provided in the title plate of this manual.

```
Moxa:~# cat /dev/ttyACM0
$GPGSV,1,1,04,24,28,123,37,21,09,054,31,19,52,213,,23,47,270,*74
$GPGGA,061824.0,2458.835139,N,12133.055835,E,1,05,19.7,-103.5,M,,,*,14
$GPRMC,061824.0,A,2458.835139,N,12133.055835,E,,290710,,,A*68
$GPGSA,A,3,24,21,06,31,16,,,,,,,,,25.5,19.7,18.5*29
$GPVTG,,T,,M,0.0,N,0.0,K*4E
```

2. Next, install the Linux GPS daemon from public repositories. GPSd is the GPS background interface that will communicate with the raw GPS device. First, terminate the cat process you have just initiated using
 

```
Moxa:~# killall cat
```

 and then install the GPS daemon:

```
Moxa:~# apt-get install gpsd
```



### ATTENTION

If you do not wish to expose the computer to the open Internet, then you may prepare a software CD in advance and use that, instead. This will require an alteration of your apt.source list, however. For more information on how to do this, consult this web page:

<http://answers.oreilly.com/topic/19-how-to-install-debian-packages-from-cd-rom/>

3. Start the GPS daemon:

```
Moxa:~# /etc/init.d/gpsd start
```

## EPM-DK03: Installing the GPS Test Clients

Next, you must install test clients for gpsd. **Xgps** is a simple X interface test client that displays GPS position, time, and velocity information along with the location of accessible satellites. **Cgps** is similar to xgps, but is able to run over a serial or terminal interface and does not feature the pictorial satellite display.

1. You may install **cgps** and **xgps** using Debian's public repositories, accessible over the Internet:

```
Moxa:~# apt-get install gpsd-clients
```



### ATTENTION

If you do not wish to expose the computer to the open Internet, then you may prepare a software CD in advance and use that, instead. This will require an alteration of your apt.source list, however. For more information on how to do this, consult this web page:

<http://answers.oreilly.com/topic/19-how-to-install-debian-packages-from-cd-rom/>

- You may now use **cgps** and **xgps** to query the GPS daemon. **Xgps** is used on the desktop, and **cgps** is used on the command line terminal, or over a serial emulator/interface. You may access either client by logging in remotely, using SSH or a virtual desktop. To get a basic report on the current GPS data, call **cgps** on the console:

```
Moxa~# : cgps
```

and you should a report that looks something like this:

```

Time:      2010-07-29T06:46:38.0Z
Latitude:  24.980836 N
Longitude: 121.552724 E
Altitude:  107.5 m
Speed:     n/a
Heading:   n/a
Climb:     0.0 m/min
Status:    3D FIX (13 secs)
GPS Type:  Generic NMEA
Horizontal Err: +/- 131 m
Vertical Err: +/- 78 m
Course Err: n/a
Speed Err: +/- 973 kph

PRN:  Elev:  Azim:  SNR:  Used:
 11   04   201   00   N
 7    11   319   00   N
 13   37   288   13   N
 24   35   108   43   Y
 21   05   045   27   N
 19   65   227   00   N
 3    75   350   25   Y
 23   44   250   00   N
 6    61   026   38   Y
 31   18   127   25   Y
 16   37   042   40   Y

0.000 0.000 ? 310.40 ? 3
GPSD,0=RMC 1280385997.000 0.005 24.980836 121.552725 107.50 139.20 83.20 0.0000
0.000 0.000 ? 280.00 ? 3

```

**NOTE** You may call the Unix man pages for more information on configuring and using the GPS daemon (man gpsd) or the GPS client (man cgps). Or visit the GPSd project website for more completely documentation: <http://gpsd.berlios.de/>

## EPM-3338: Driver Installation

### EPM-3338: Wi-Fi Module

Follow these steps to install the Wi-Fi module for the EPM-3338.

- Ensure that the device driver is activated:

```
Moxa:~# modprobe ath9k
Moxa:~# lsmod | grep ath
```

- Turn on the network interfaces **wlan0** and **wlan1**:

```
Moxa:/home# ifconfig wlan0 up
```

- Install the Wi-Fi control and monitoring software:

```
Moxa:/home# apt-get install wpasupplicant wireless-tools
```

- Create the correct links for **wpa\_supplicant**:

```
Moxa:/etc/network/if-up.d# ln -sf /etc/wpa_supplicant/ifupdown.sh wpasupplicant
Moxa:/etc/network/if-down.d# ln -sf /etc/wpa_supplicant/ifupdown.sh wpasupplicant
Moxa:/etc/network/if-pre-up.d# ln -sf /etc/wpa_supplicant/ifupdown.sh
```

- Edit **wpa\_supplicant.conf**:

```
ctrl_interface=DIR=/var/run/wpa_supplicant
# home network;
# allow all valid cipher
Network={
    ssid="Vodafone_AP"
    scan_ssid=1
    key_mgmt=WPA-PSK
    psk="12345678"
}
```

6. To control or monitor the wireless client you may use the following command:

```
Moxa:/home@ wpa_cli -p /var/run/wpa_supplicant
```

**NOTE** View the following reference for more information on wpa\_supplicant and hostapd.

[http://hostap.epitest.fi/wpa\\_supplicant/](http://hostap.epitest.fi/wpa_supplicant/)

Visit the following website for the wpa

configuration. [http://hostap.epitest.fi/gitweb/gitweb.cgi?p=hostap.git;a=blob\\_plain;f=wpa\\_supplicant/README](http://hostap.epitest.fi/gitweb/gitweb.cgi?p=hostap.git;a=blob_plain;f=wpa_supplicant/README)

View the following reference for more information on iw.

<http://linuxwireless.org/en/users/Documentation/iw>

## EPM-3338: Cellular Module

Follow these steps to install the cellular module for the EPM-3338, which will use the PPP daemon to connect. The **pppd** options file is located at `/etc/ppp/peers/provider`.

To set up **pppd** for cellular connectivity:

1. Configure the `/etc/ppp/peers/provider` file. This file contains all of the information the server to which you will be connecting using the point-to-point protocol:
  - a. First, check if the name of module port is correct. It should be `/dev/ttyUSB1` for the first module, `/dev/ttyUSB4` for the second one.
  - b. Make sure the local option is enabled. This option ignores the CD (Carries Detect) signal.
2. Configure `/etc/chatscripts/provider`:
  - a. First, check that the **packet data protocol type** and **access point name (APN)**, given by your ISP) are correct. A basic command would be:
 

```
AT+CGDCONT=1, <PDP_type>, <APN>
```

 If your PDP type and APN were (respectively) **IP** and **Internet**, the above command would be written:
 

```
AT+CGDCONT=1, "IP", "Internet"
```
  - b. Check the ATD dialout number:
 

```
ATD <number>
```
  - c. Connect using the configuration files: \
 

```
Moxa~#: pppd call chtgprs
```
  - d. Confirm your configuration is correct by reading the configuration file to connect:
 

```
Moxa~#: pppd call chtgprs
```
3. Lastly, examine the connection status. If you have successfully connected, the device ppp0 (or pppn) has been established. To check if this is the case, issue the command:

```
Moxa~#: ifconfig ppp0
```

You should see some output similar to this:

```
root@Moxa:~# ifconfig eth0 192.168.100.100
ppp0   Link encap Point-to-Point Protocol
        inet addr 192.76.32.3  P-t-P 129.67.1.165 Mask 255.255.255.0
        UP POINTOPOINT RUNNING  MTU 1500  Metric 1
        RX packets 33 errors 0 dropped 0 overrun 0
        TX packets 42 errors 0 dropped 0 overrun 0
root@Moxa:~$
```

## EPM-3338: Troubleshooting Cellular Communication

To enable verbose debugging messages in **pppd**, you may enable the **debug** and **logfile** options in **/etc/ppp/peers/provider**.

```
#Debug option---
#You call tail -f /var/log/ppp.log &
debug
logfile /var/log/ppp.log
```

The log will be available at **/var/log/ppp.log** for more detailed message.

## EPM-3338: GPS Module

The EPM-3338 module comes with a built-in GPS module. The kernel module for the native GPS card provided by the EPM-DK03 is precompiled into the Linux kernel binary, so there is no need to install another one. This GPS module is read and managed by the **gpsd** daemon, and accessed through the ports **/dev/ttyACM0** and **/dev/ttyACM1** (if a 2<sup>nd</sup> GPS module is installed). Follow these steps for installation:

1. First check if the GPS card is transmitting raw data by issuing the following command to the device node, **/dev/ttyACM0**. If no data is being returned by the card, first try adjusting the GPS antenna to troubleshoot the problem. If there is no way of establishing reception, contact Moxa technical support at the phone number provided in the title plate of this manual.

```
Moxa:~# cat /dev/ttyACM0
$GPGSV,1,1,04,24,28,123,37,21,09,054,31,19,52,213,,23,47,270,*74
$GPGGA,061824.0,2458.835139,N,12133.055835,E,1,05,19.7,-103.5,M,,,,*14
$GPRMC,061824.0,A,2458.835139,N,12133.055835,E,,,290710,,,A*68
$GPGSA,A,3,24,21,06,31,16,,,,,,,,,25.5,19.7,18.5*29
$GPVTG,,T,,M,0.0,N,0.0,K*4E
```

2. Next, install **GPSd**, the GPS background interface that will communicate with the raw GPS device. First, terminate the **cat** process you have just initiated using either **<ctrl> + c**, or :

```
Moxa:~# killall cat
```

and then install the GPS daemon:

```
Moxa:~# apt-get install gpsd
```

3. Start the GPS daemon:

```
Moxa:~# /etc/init.d/gpsd start
```

4. Next, you must install the GPS test clients **cgps** and **xgps**, which will interact with **gpsd**:

```
Moxa:~# apt-get install gpsd-clients
```

5. You may now use **cgps** and **xgps** to query the GPS daemon. **Xgps** is used on the desktop, and **cgps** is used on the command line terminal, or over a serial emulator/interface. You may access either client by logging in remotely, using SSH or a virtual desktop. To get a basic report on the current GPS data, call **cgps** on the console:

```
Moxa~#: cgps
```

and you should a report that looks something like this:

```

Time:      2010-07-29T06:46:38.0Z
Latitude:  24.980836 N
Longitude: 121.552724 E
Altitude:  107.5 M
Speed:     n/a
Heading:   n/a
Climb:     0.0 M/min
Status:    3D FIX (13 secs)
GPS Type:  Generic NMEA
Horizontal Err: +/- 131 M
Vertical Err: +/- 78 M
Course Err: n/a
Speed Err: +/- 973 kph

```

| PRN: | Elev: | Azim: | SNR: | Used: |
|------|-------|-------|------|-------|
| 11   | 04    | 201   | 00   | N     |
| 7    | 11    | 319   | 00   | N     |
| 13   | 37    | 288   | 13   | N     |
| 24   | 35    | 108   | 43   | Y     |
| 21   | 05    | 045   | 27   | N     |
| 19   | 65    | 227   | 00   | N     |
| 3    | 75    | 350   | 25   | Y     |
| 23   | 44    | 250   | 00   | N     |
| 6    | 61    | 026   | 38   | Y     |
| 31   | 18    | 127   | 25   | Y     |
| 16   | 37    | 042   | 40   | Y     |

```

0.000 0.000 ? 310.40 ? 3
GPRMC,0.0,R,0.0,M,0.0,A,24.980836,E,121.552725,E,107.5,M,0.0,H,0.0,A,0.0,E,A,0.0,M,0.0,A,0.0
0.000 0.000 ? 280.00 ? 3

```

**NOTE** Use the GNU system manual command to get more information on the GPS daemon interface and client:

Moxa ~#: man gpsd

Moxa ~#: man cgps

Or visit the GPS project website for more information: <http://gpsd.berlios.de/>

# Windows System

## EPM-3032: Driver Installation

Before using the EPM-3032 expansion module, you need to update the driver. Install the driver before inserting the expansion module in the slot.

1. Find **EPM3032Setup.exe** on your software CD and execute it to install the driver. At the welcome screen, click **Next**.

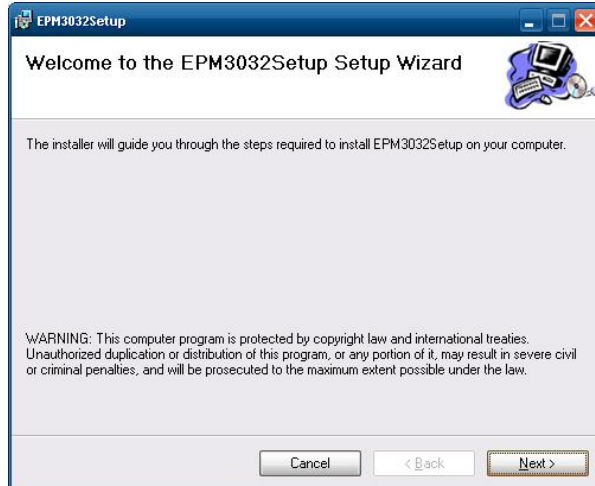

2. Click **Next** to **install** using default settings.



3. Click **Next** to start the installation.

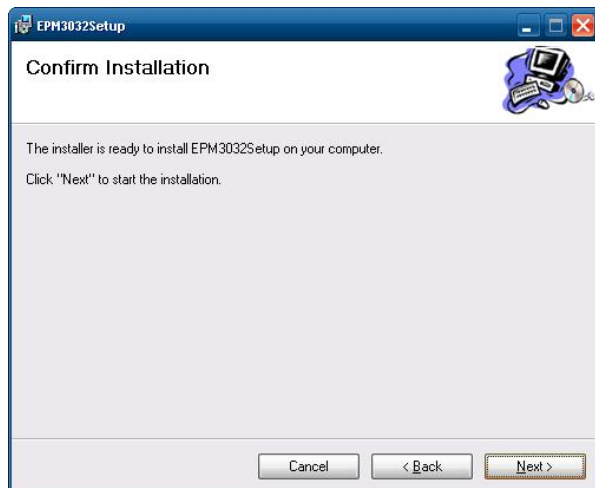



- Click **Close** to complete the installation.
- At this point, shut down the computer and insert the EPM-3032 expansion module into the embedded computer, and then reboot the computer.
- The system will locate the new hardware; select **No, not this time** and then click **Next**.



- Select **Install the software automatically** and then click **Next**.

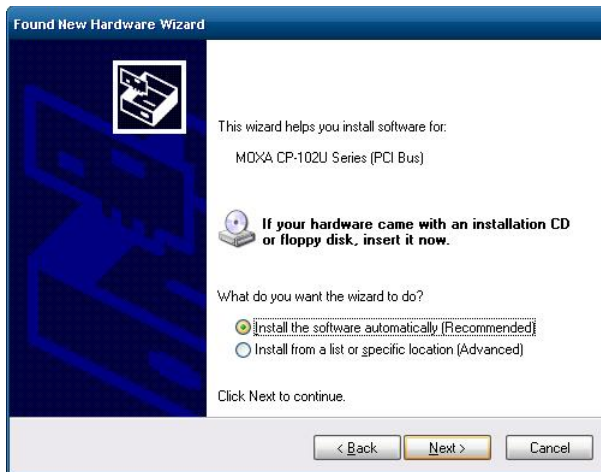

- The driver will be **installed** automatically. The module should be listed in the Device Manager window. At this point you can start using the module.

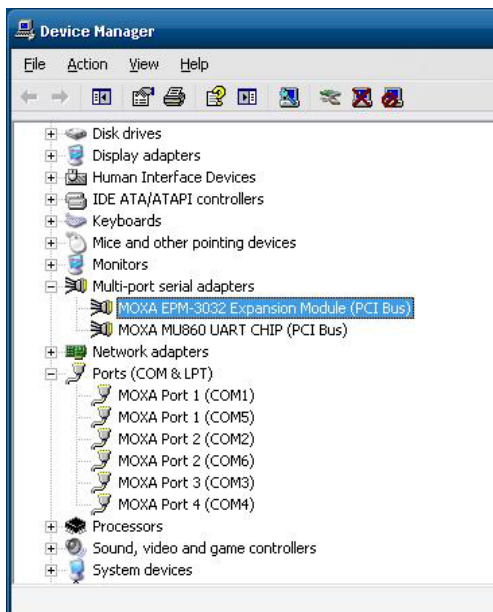

## EPM-3032: Configuring Serial Port Mode

Take the following steps to configure the operation mode of each COM port:

1. Go to the **Control Panel** → **Ports (COM & LPT)** and select the COM port; e.g., MOXA Port 0 (COM1).
2. Right-click the COM port and then click **Properties**.

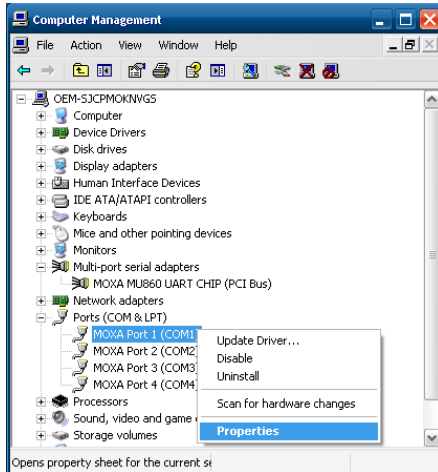

3. Click the **Port Settings** tab and then select the interface you would like to use.
4. Click **OK** to apply the settings.

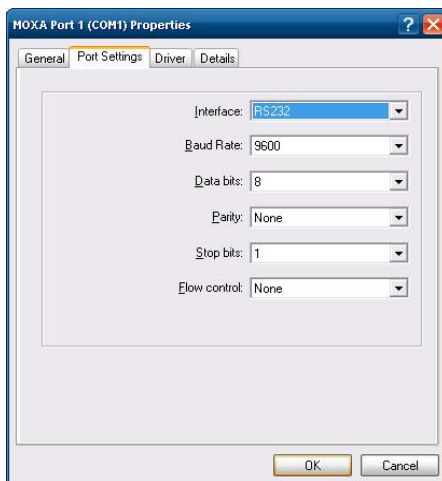

In some situations, you may want to change the port name to match the name used by your program. Take the following steps to change port names:

1. Go to **Control Panel** → **Multi-port serial adapters** and select the adapter.
2. Right-click the adapter and select **Properties**.

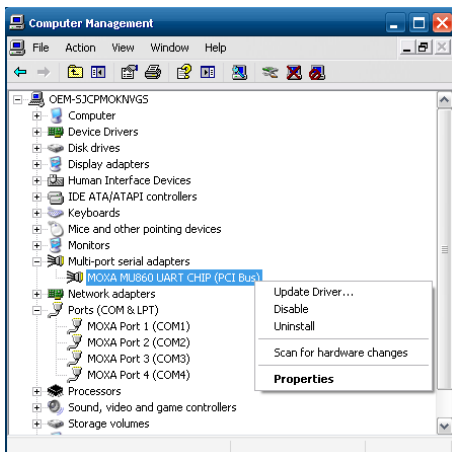

- Click the **Port Configuration** tab, select the port, and then click **Port Setting**.

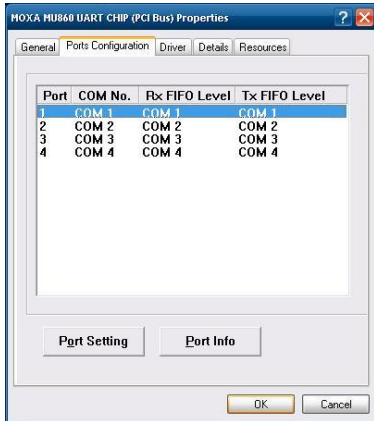

- To change the port name separately uncheck **Auto Enumerating COM Number**.

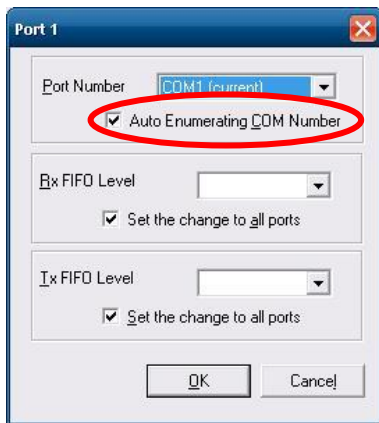

- Select the new port name and then click **OK**.

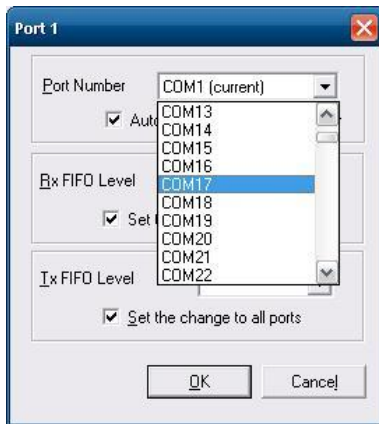

- Make sure the port names are correct, and then click **OK** to activate the settings.

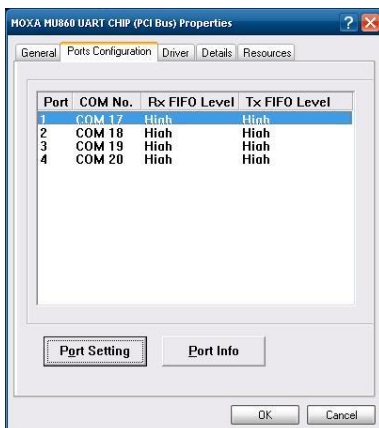

7. Refer to **Ports (COM & LPT)** to verify that the port names have been changed.

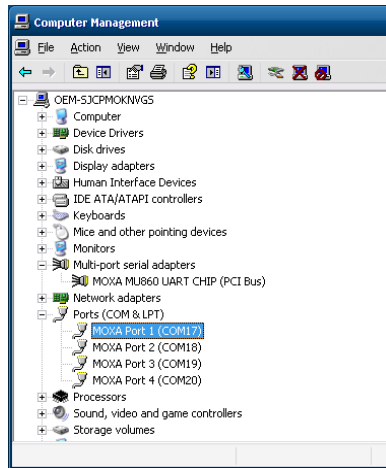

**NOTE** Make sure each port name is unique; using duplicate names will result in some devices being inaccessible.

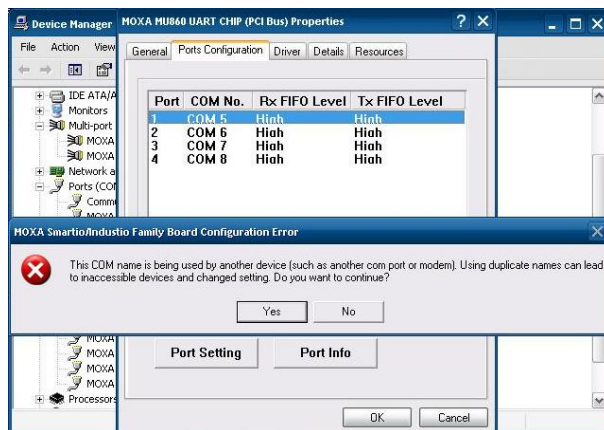

## EPM-3032: Changing the Software-Selectable UART Mode

The V24XX series features programmable UART that may be changed using system commands. The sample code changing the UART mode that is shown here can be found on the Software DVD in `\examples\C++\`, as `UartMode`.

The code snippet is as follows:

```
int port=0,mode=0;
int n=0;
WCHAR sin;
WCHAR wcs_port[3],wcs_mode[3];
printf("UART Mode Test Program\n");
printf("\t (0) Exit Program\n");
printf("\t (1) Display UART Mode\n");
printf("\t (2) Set UART Mode\n");
sin=getwchar();
n=_wtoi(&sin);

do
{
```

```

switch (n)
{
    // if char == '1', display the UART Mode
    case 1:
        printf("Input the Port Number (5~8) = \n");
        wscanf(L"%s",wcs_port);
        port=_wtoi(wcs_port);
        mode=uart_getmode(port);
        if(mode==(-1))
        {
            printf("Invalid value!!\n");
            break;
        }
        printf("COM%d=%s\n",port,mode_array[mode]);

        break;
    // if char == '2', Set the UART Mode
    case 2:

        //Get Port Number
        printf("Input the Port Number (5~8) = \n");
        wscanf(L"%s",wcs_port);
        port=_wtoi(wcs_port);

        //Get Mode Value
        printf("Input the Mode value (0 ~ 3) = ");
        wscanf(L"%s",wcs_mode);
        mode=_wtoi(wcs_mode);

        //Set UART Mode
        if(uart_setmode(port,mode)==-1)
        {
            printf("Invalid value!!\n");
            printf("Set UART Mode Fail!!\n");
        }
        else
        {
            printf("COM%d=%s\n",port,mode_array[mode]);
        }
        break;
    }
    getch();
    sin = getch();
    n = _wtoi(&sin);
} while (n != 0);
return 0;

```

## EPM-3438: Driver Installation

Before installing the EPM-3438, select counter mode or DI mode for the module.

If dip-switch 1 on the EPM-3438 is on, the DI0 will work in digital input port mode. The DI0 just reflects whether the input signal status is HIGH or LOW. If DIP switch 2 on the EPM-3438 is on, the DI0 works as a 16-bit counter.

The counter is increased when the input pulse is toggled from low to high. See the following figures for DIP switch settings.

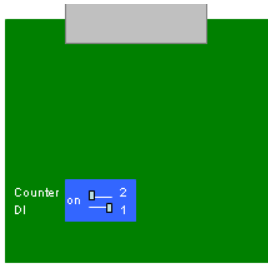

Counter mode

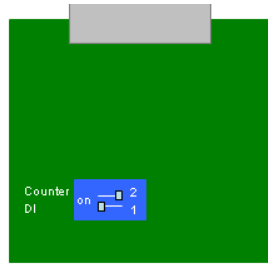

DI mode

Before using the EPM-3438 expansion module, you need to update the driver. Be sure to install the driver before inserting the expansion module in the slot.

Take the following steps to install the EPM-3438 module driver:

1. Run **EPM3438Setup.exe** to begin installation and then click **Next**.

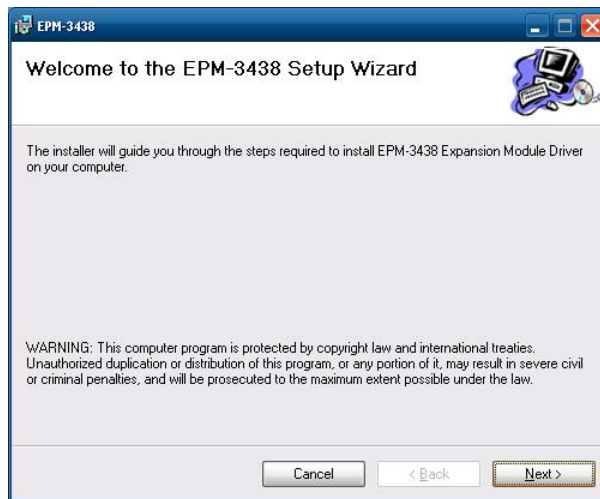

2. Click **Next** to accept the default settings, and then click **Next** again to begin the installation.



3. Click **Close** to complete the installation, then then shut down the computer, insert the EPM-3438 expansion module into the embedded computer, and then reboot the computer.

4. The system should find the new hardware and install the driver automatically. Check the **Windows Device Manager** to verify.

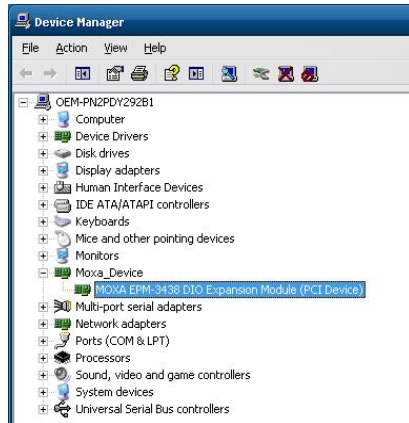

## EPM-3438: Programming Guide

Some operations can be configured through programming; the following "DIO" example can be found on the software DVD at `\examples\C++\`.

### Moxa functions for DI/DO

|             |  |
|-------------|--|
| Function    | <b>HANDLE mxdgio_epm3438_open(int HWIndex);</b>  |
| Description | This function opens access to the DIO device.  |
| Input       | <HWIndex> The first or second EPM-3438 board.  |
| Output      | None   |
| Return      | When successful, this function returns an access to the DIO device; otherwise, an error. |

|             |  |
|-------------|--|
| Function    | <b>void mxdgio_close(HANDLE fd);</b>               |
| Description | This function closes the access to the DIO device. |
| Input       | <fd> The access to the device.                     |
| Output      | None   |
| Return      | None   |

|             |  |
|-------------|--|
| Function    | <b>int mxdgio_get_input_signal(HANDLE fd, int port);</b>   |
| Description | This function gets the signal state of a digital input channel.  |
| Input       | <fd> The access to the device.<br><port> port #  |
| Output      | <state> DIO_HIGH (1) for high, DIO_LOW (0) for low   |
| Return      | Returns 1 for a high signal or 0 for a low signal, if successful. Otherwise, it returns a value of -1. |

|             |  |
|-------------|--|
| Function    | <b>int mxdgio_get_output_signal(HANDLE fd, int port);</b>  |
| Description | This function gets the signal state of a digital output channel.                                       |
| Input       | <fd> The access to the device.<br><port> Port number   |
| Output      | None   |
| Return      | Returns 1 for a high signal or 0 for a low signal, if successful. Otherwise, it returns a value of -1. |

|             |  |
|-------------|--|
| Function    | <b>int mxdgio_set_output_signal_high(HANDLE fd, int port);</b>                 |
| Description | This function sets a high signal to a digital output channel.                  |
| Input       | <fd> The access to the device.<br><port> Port number.                          |
| Output      | none.  |
| Return      | When successful, this function returns 0. When an error occurs, it returns -1. |

|             |  |
|-------------|--|
| Function    | <b>int mxdgio_set_output_signal_low(HANDLE fd, int port);</b>                  |
| Description | This function sets a low signal to a digital output.                           |
| Input       | <fd> The access to the device.<br><port> Port number.                          |
| Output      | none.  |
| Return      | When successful, this function returns 0. When an error occurs, it returns -1. |

### Moxa I/O control definitions for COUNTER

|         |               |                          |
|---------|---------------|--------------------------|
| #define | COUNTER_NODE1 | "/dev/epm_3438_counter1" |
| #define | COUNTER_NODE2 | "/dev/epm_3438_counter2" |

|             |   |
|-------------|---|
| Function    | <b>int mxdgio_epm3438_get_counter(int fd);</b>                |
| Description | get the counter value   |
| Input       | <fd> The access to the counter device.<br><port> Port number. |
| Output      | none.   |
| Return      | the counter value   |

|             |   |
|-------------|---|
| Function    | <b>int mxdgio_epm3438_clear_counter(int fd);</b>              |
| Description | Clear the counter value                                       |
| Input       | <fd> The access to the counter device.<br><port> Port number. |
| Output      | none.   |
| Return      | 0:clear success; -n: clear fail                               |

## EPM-3337: Driver Installation

1. Navigate to the directory  
 \Drivers\HC25\HC25\_0205ussb\_ndis\_driver  
 \install\program files\Siemens\  
 HC25 Connection Manager  
 and then double-click **DPInst.exe**. This will open the installation wizard.
2. Accept the default configuration by clicking through, and then wait for the driver to install.
3. You should see the drivers listed in the final window of the **Device Driver Installation Wizard**. Click **Finish** to complete the driver installation.

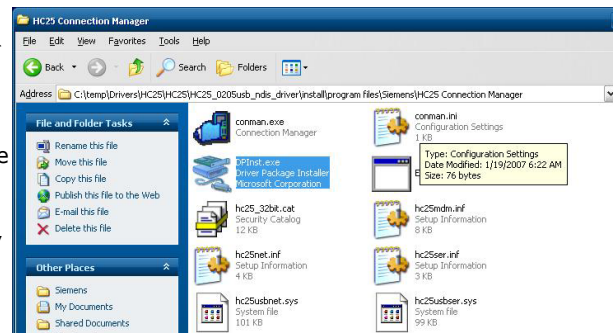



- Navigate to the `\HC25\HC25_usb_ndis_driver\program files\` directory and double-click **HC25 Connection Manager.msi**.

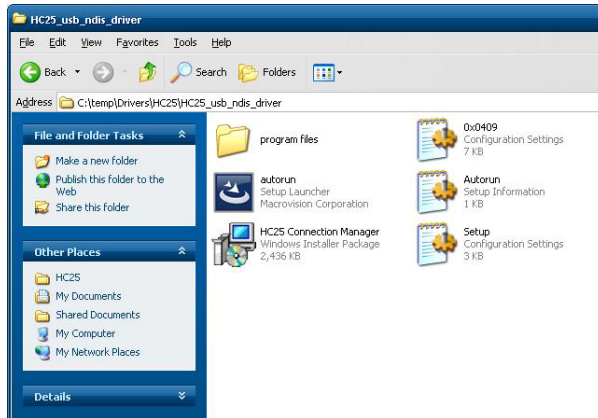

- Click **Install**.

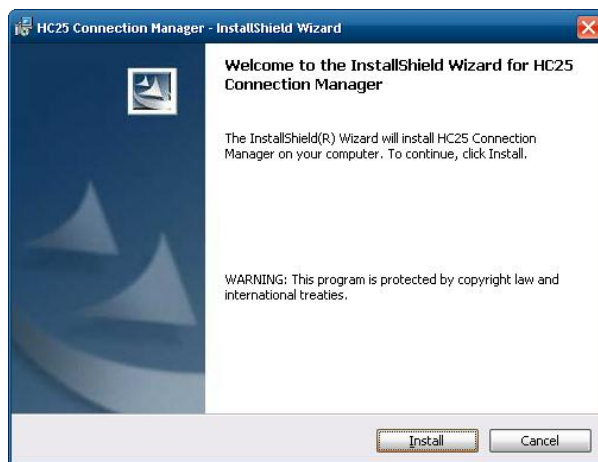

- During the **installation** process, if you encounter the following error message, just ignore it and click **OK**.



- After the installation is completed, you should see **Siemens HC25 HSDPA USB Modem**, **Siemens HC25 Wireless Ethernet Adapter**, and **Siemens HC25 USB COM Port** all listed in the **Windows Device Manager** window.

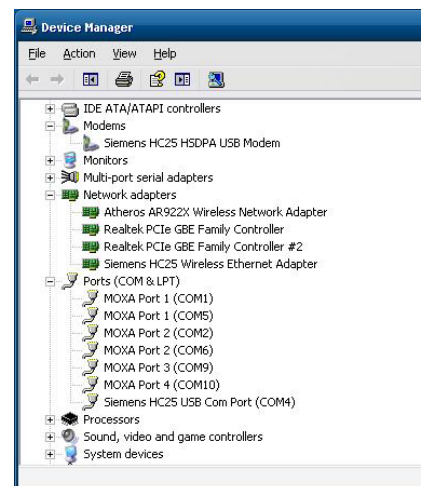

- Change to the \HC25\HC25\Winmux2K directory and double-click **wmux2k.exe**.

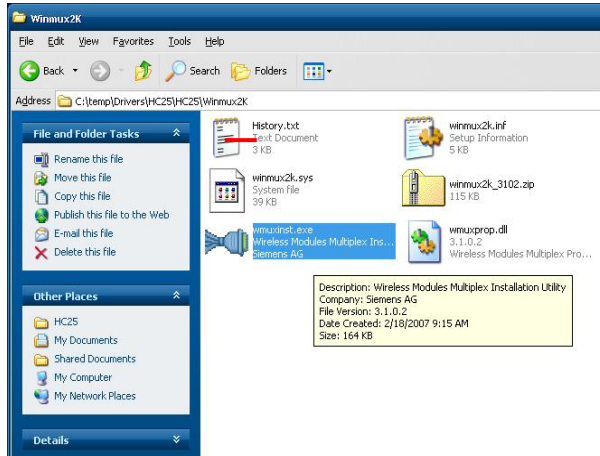

- Click **Start Scan**.

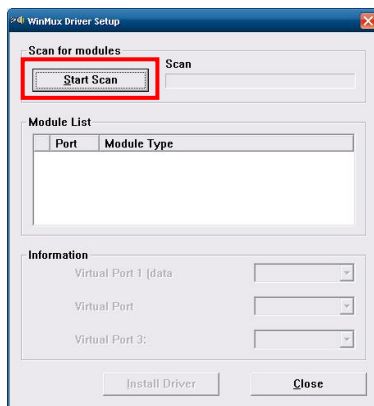

- After the scan is completed you may click **Install Driver**.

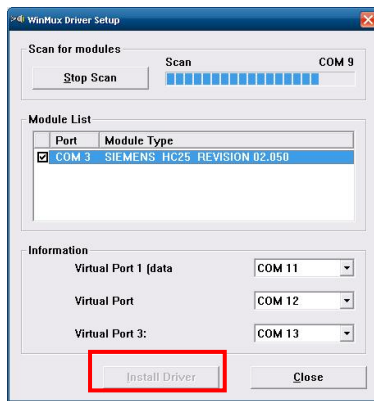

- Click **Install Driver** and then **Continue Anyway** once the scan is complete.



- Click **OK** to complete the installation.

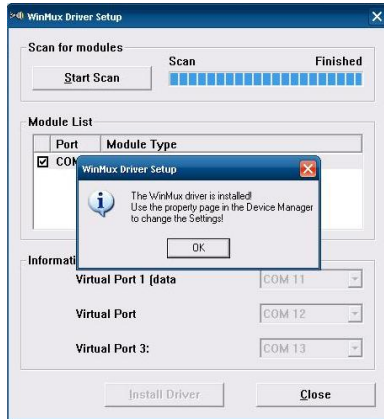

- Serial Multiplexer** should appear in you the Device Manager window.

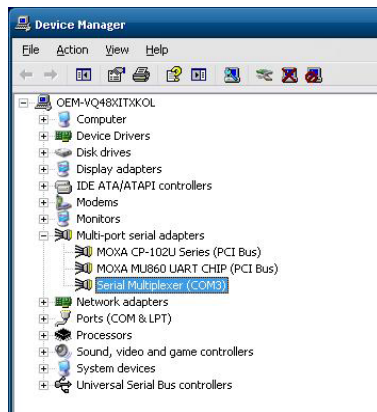

- Right-click on **Serial Multiplexer** and select **Properties**. You will see that 3 virtual serial modem ports have been generated; you can change the port numbers using the drop-down lists.

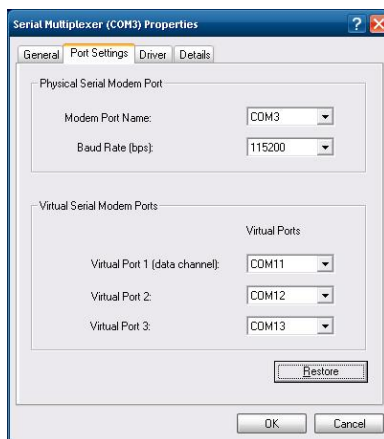

**NOTE** Make sure each port name is unique; duplicate names will create glitches.

## EPM-3338: Wireless Module Driver Installation

1. If the **Found New Hardware Wizard** appears, click **Cancel** to stop and exit the wizard.



2. Navigate to the **Install\_CD** directory and double-click **setup.exe** to install the driver.

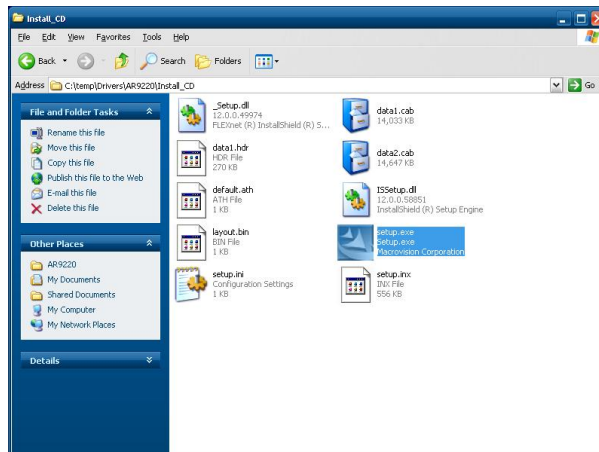

3. Select the language you want to use for the installation, and click **Next** (English default).

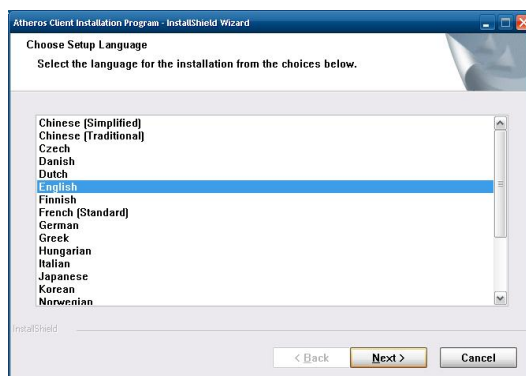

4. Click through to the license agreement page, and select **I accept the terms**; then click **Next**.

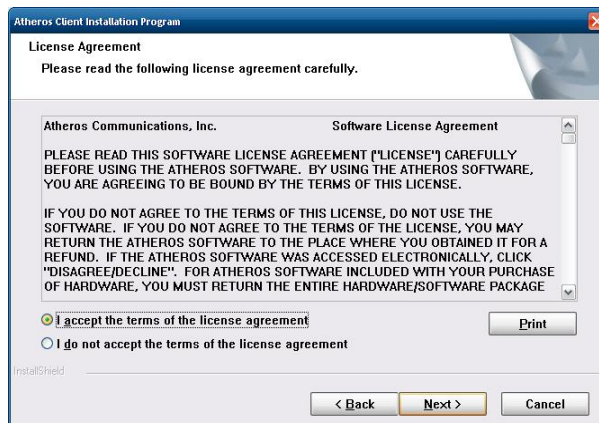

5. Select **Install Client Utilities and Driver** and then click **Next**.

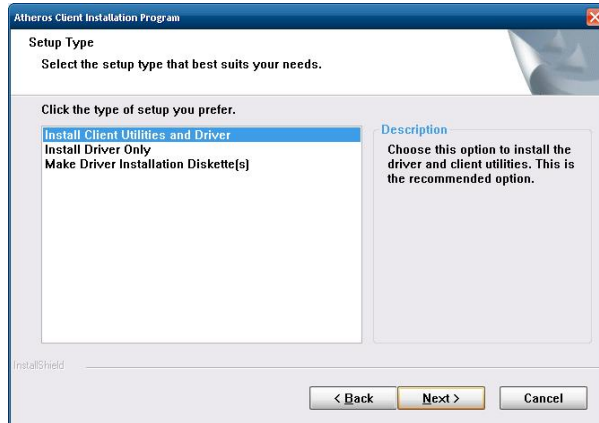

6. Accept the default installation location by clicking through the next two screens.

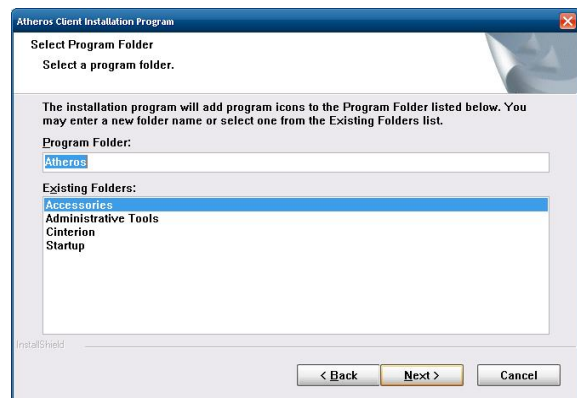

7. Click through the message screen; you will want to accept the Atheros Client Utility.

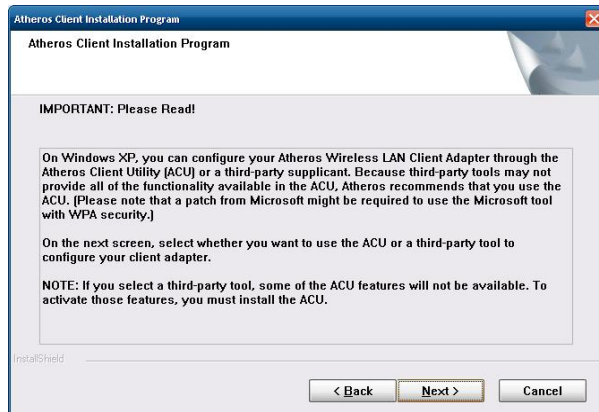

8. Select **Atheros Client Utility (ACU) and Supplicant** and then click **Next**.

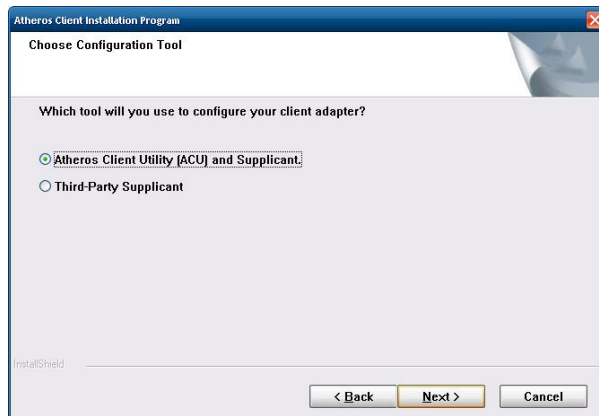

- Click **Yes**.

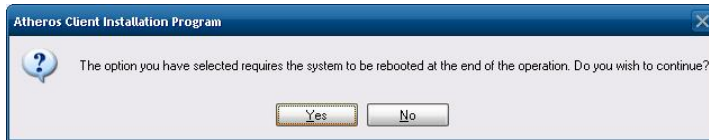

- Click **OK** and wait for the driver to finish installing; then, click through to the restart screen.



- You may select **Yes, I want to restart my computer now** to complete the installation, or elect to continue installing other software first, before restarting the computer.

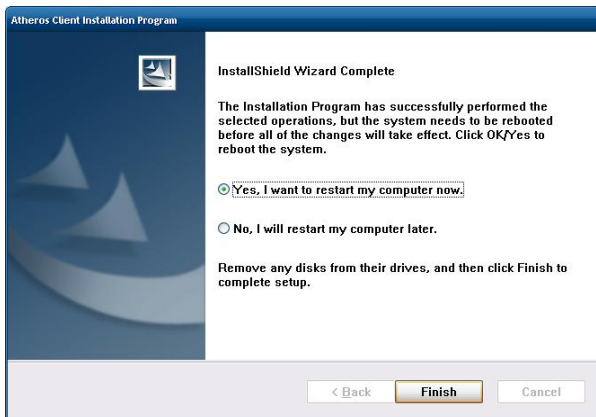

- After the next reboot you should see **Siemens HC25 HSDPA USB Modem**, **Siemens HC25 Wireless Ethernet Adapter**, and **Siemens HC25 USB COM Port** listed in the **Windows Device Manager**.

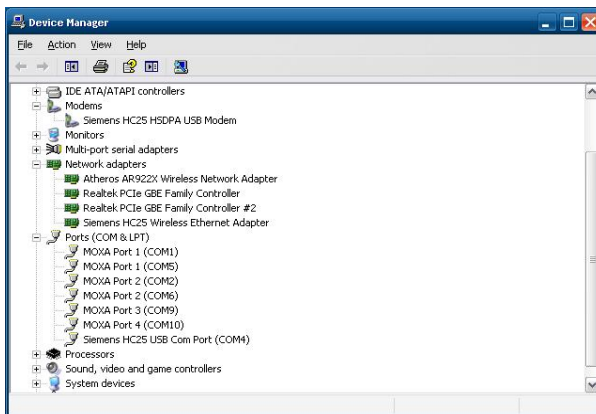

## EPM-3338: Configuring a GPRS/HSDPA Connection (no GPS)

In this section we illustrate how to establish a connection using the **Siemens HC25 Connection Manager**.

- Go to **Control Panel** → **System**.

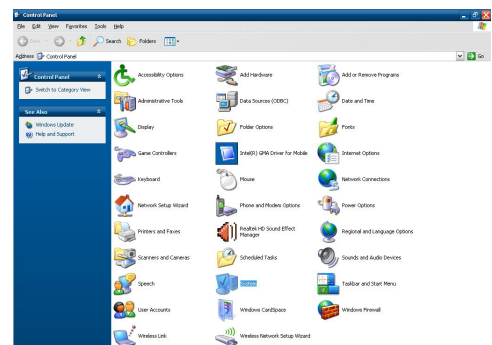

2. Click **Hardware** → **Device Manager**.

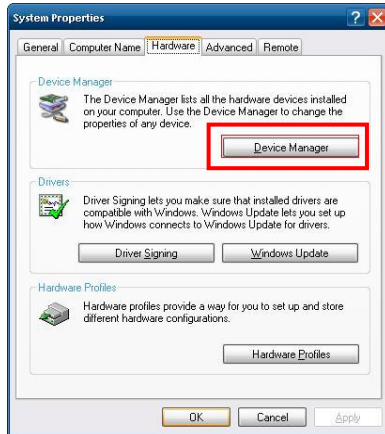

3. Right-click **Serial Multiplexer** and select **Properties**, then open the **Port Settings** tab.

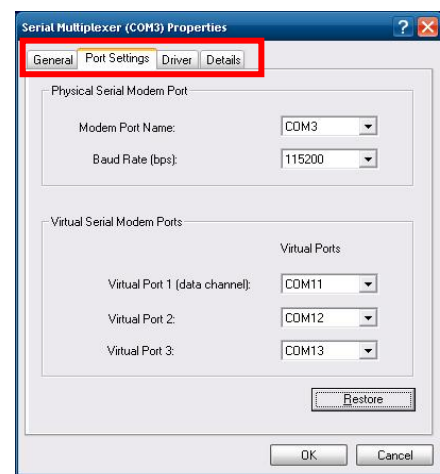
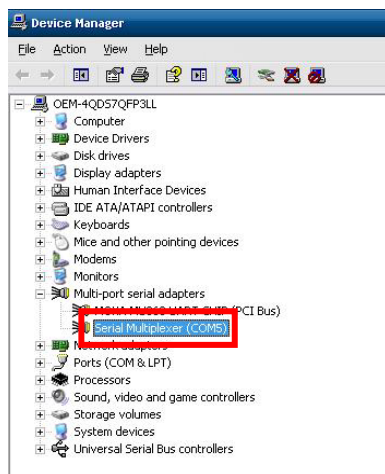

4. First, verify the SIM card is ready; then open **Virtual Port 2** and enter the AT command `at+cpin?`.

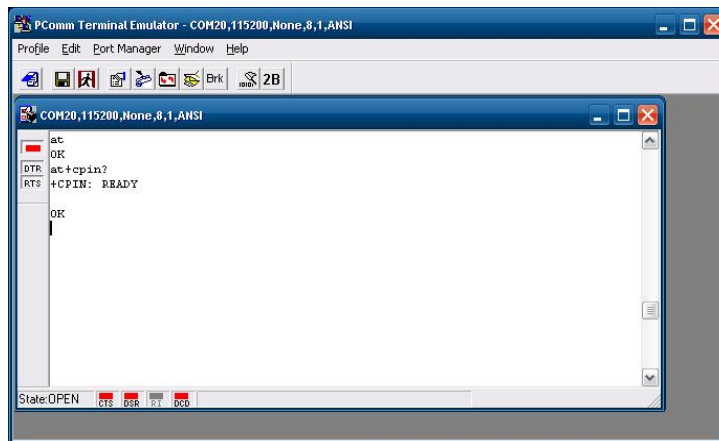

**NOTE** Before you verify the SIM card status, check whether or not the PIN code has been submitted.

- Navigate to the **SIM** tab, select **Verify PIN** from the **Action** drop-down under the **SIM Actions** section.

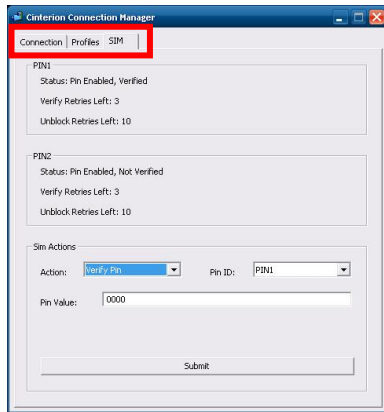

- Next, select the **Connection** tab and select the device from the drop-down list; then check the **APN Name** box from the list below and enter your APN's Name.

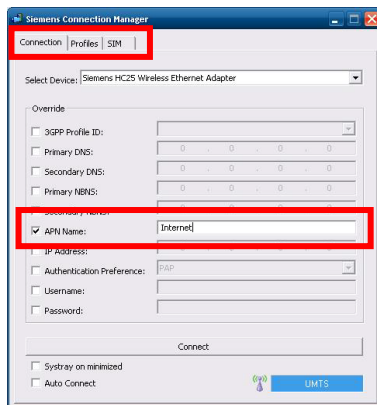

- Click **Connect** to connect to the Internet and establish the wireless connection. You may check the wireless connection by clicking on the **Wireless Connections → Properties** in the **Windows System Tray**.

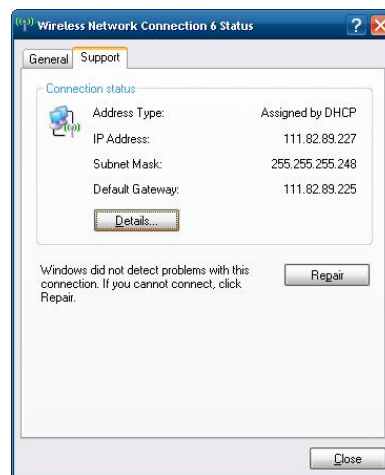
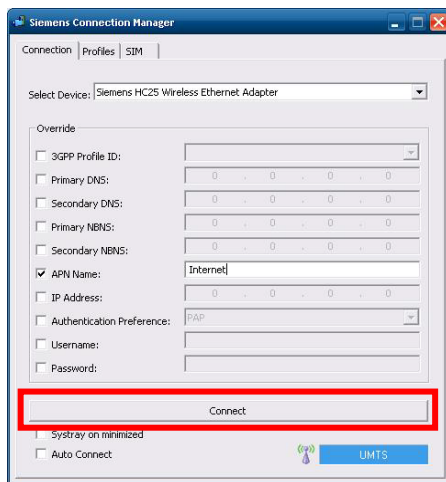

**WARNING**

Do not close the program while the connection is being established, or the device driver may become corrupted and cease to work properly.



8. At this point you can access this wireless network connection.

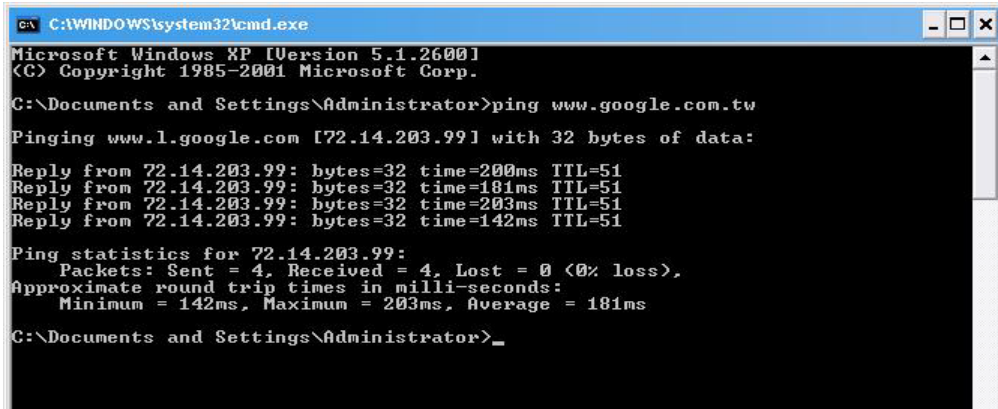

## EPM-3338: Configuring GPS

GPS functionality is only enabled when the module is in multiplexer mode. A **Winmux2K** driver is available for configuring the module in multiplexer mode. In multiplexer mode, the system will generate virtual COM ports to communicate, and the modem port will become one of the virtual COM ports.

Take the following steps below to enable GPS functionality:

1. Start the **Device Manager** and check the three virtual COM ports, then start **Terminal Emulator** and open the 2nd virtual COM port (COM18).

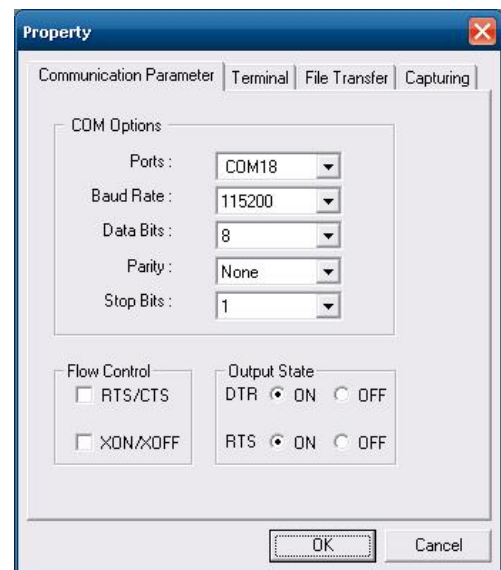
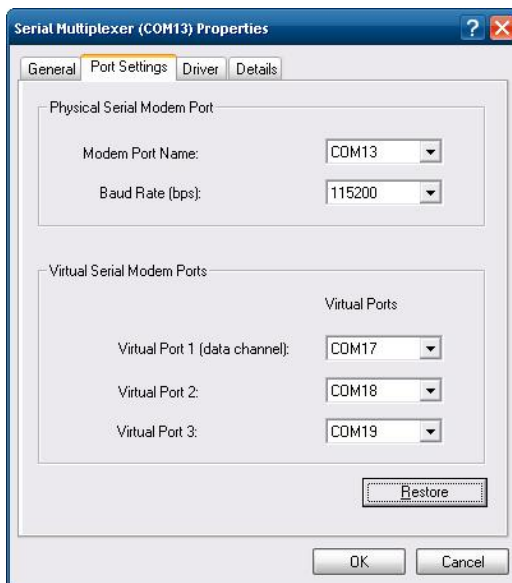

2. Enter `at^sgps=4` to enable GPS functionality.

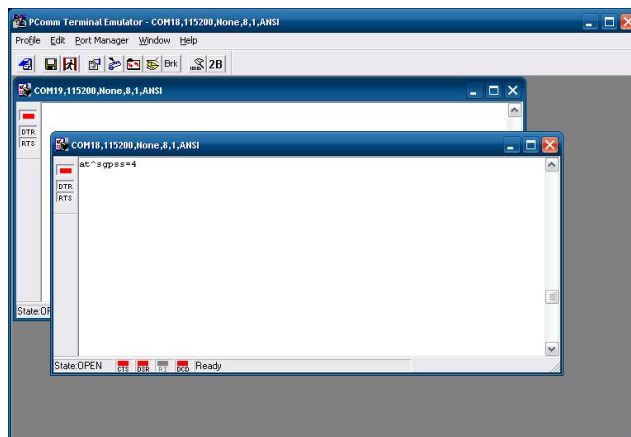

- You may view the **information** returned by the GPS in a serial terminal (e.g., **Windows HyperTerminal**) and verify that the device is working properly correct.

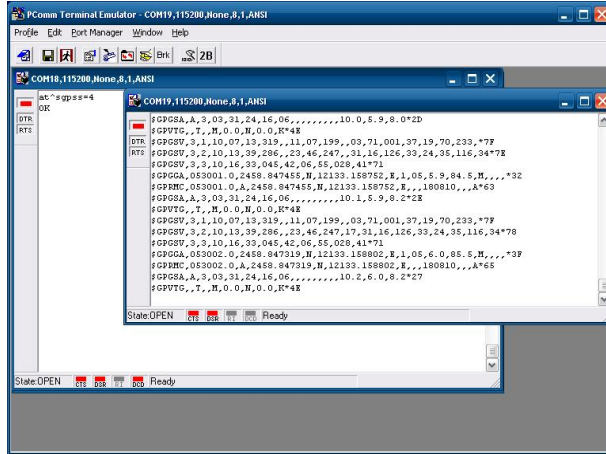

## EPM-3338: Configuring a Wi-Fi/802.11 Connection

The EPM-3337 module includes a wireless module. In this section we explain how to connect to an access point with WEP/WPA/WPA2(RSN) encryption.

To configure a wireless connection, do the following:

- Double-click on the **Atheros client utility** shortcut on the desktop. Click on the **Profile Management** tab, and then click the **SCAN** button.

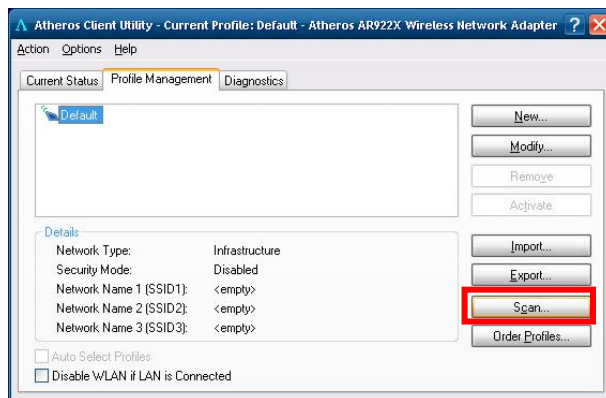

- Select the access point that you want to connect to and then click **Activate**.

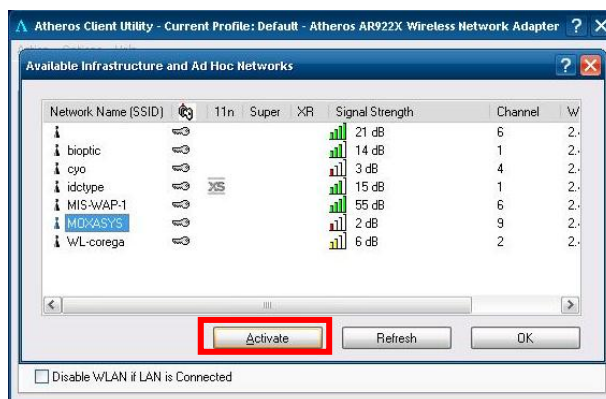

3. Enter the **Profile Name** and then select the **Security** tab.

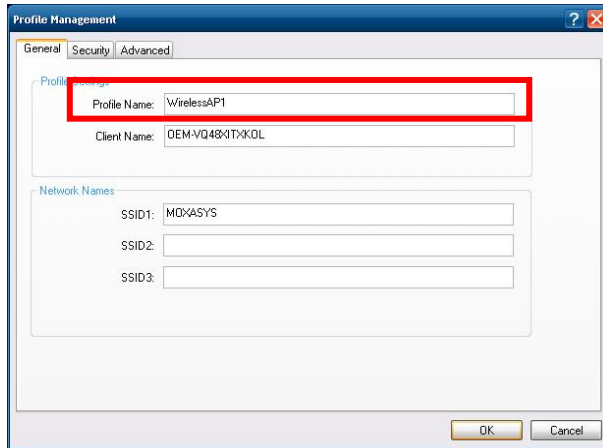

1. Moxa recommends selecting WPA2 as your security option; then click **Configure**.

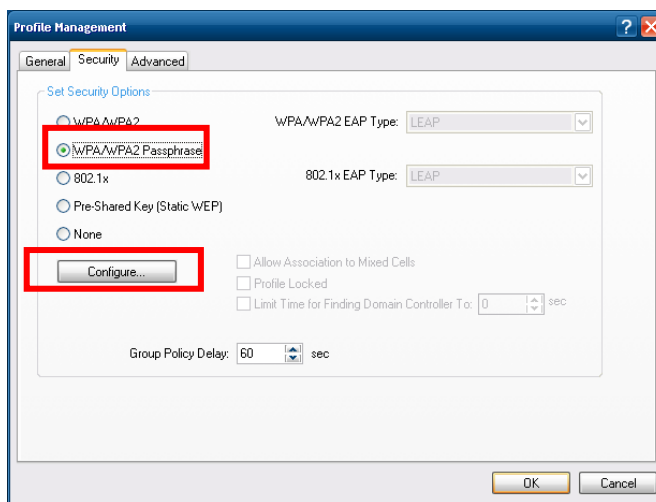

Allow Association to Mixed Cells

Check this box if the access point with which the client adapter is to associate has WEP set to optional and WEP is enabled on the client adapter. Otherwise, the client will be unable to establish a connection with the access point.

Profile Locked

This will lock the profile.

Limit Time for Finding Domain Controller to XX Seconds

Check this box and enter the number of seconds (up to 300) after which the authentication process times out when trying to find the domain controller. Entering zero is the same as disabling this feature, with no time limit enforced when searching for domain controllers.

Group Policy Delay

Specify how much time elapses before the Windows logon process starts group policy. Group policy is a Windows feature used by administrators to specify configuration options for groups of users. The objective is to delay the start of Group Policy until wireless network authentication occurs. Valid ranges are from 0 to 65535 seconds. The value that you set goes into effect after you reboot your computer with this profile set as the active profile.

This drop-down menu is active only if you choose EAP-based authentication.



**WARNING!**

**Moxa strongly advises against the use of the WEP and WPA encryption standards.** Both are now officially deprecated by the Wi-Fi Alliance, and are considered insecure. To guarantee proper Wi-Fi encryption and security, please use WPA2 with the AES encryption algorithm, and configure it with a strong password.

- Configure a strong passphrase for your WPA2 network. This may be an 8 to 63 character ASCII passphrase, or up to a 64 digit hexadecimal passphrase.

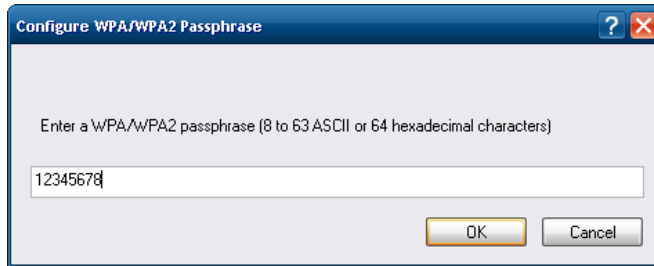

- If you want to use an Extensible Authentication Protocol, then you may choose the protocol from the drop-down boxes at the right. If you wish to use a RADIUS server, then you will need to configure your connection for 802.1X authentication. When you have configured the connection, click OK and exit the setup wizard.

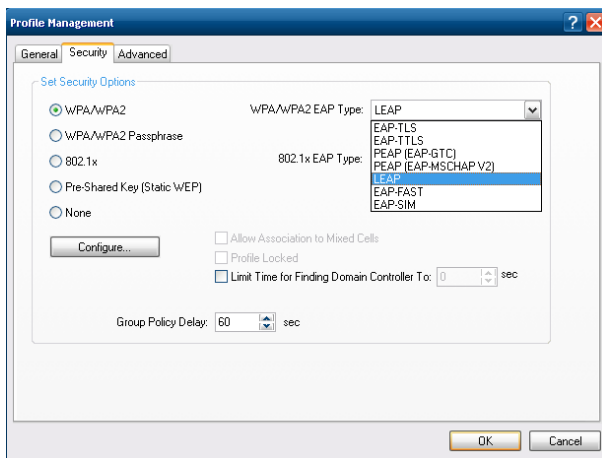

- The connection should now be established. You may check this using the **Properties** tab under the **Network Connections** icon in the **Windows Systray**.

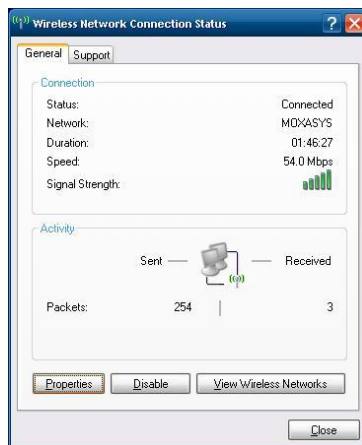

## EPM-3338: Getting Wireless Module Information

The **Atheros Client Utility** can be used to get wireless information and to manage wireless connections.

1. Double-click the **Atheros client utility** shortcut on the desktop and then select the **Current Status** tab.

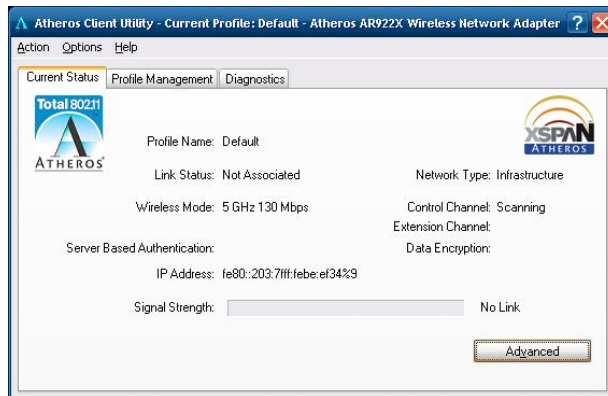

2. Click the **Advanced** button. You will see the status of the current wireless connection.

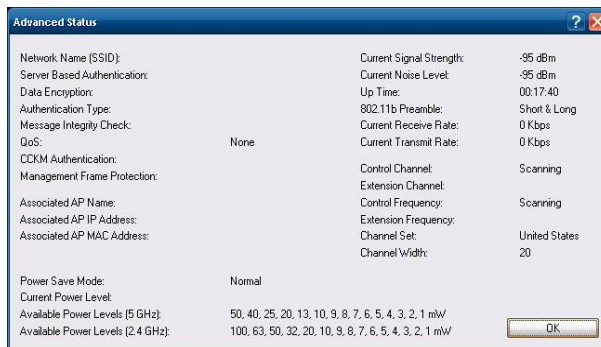

## EPM-3112: Driver Installation

Take the following steps to install the CAN BUS driver:

1. Double-click **EPM-3112\_V1.0.msi** to open the setup wizard that will install the module. Click **Next**.
2. Click **Next** to accept the installer defaults, and then click through the next dialog to install the driver.



3. After the driver is installed, click **Close** to complete the driver setup.

- Next, open the **Windows Device Manager**, right click on the computer located at the top of the tree, and select **Scan for hardware change** to finish the installation.

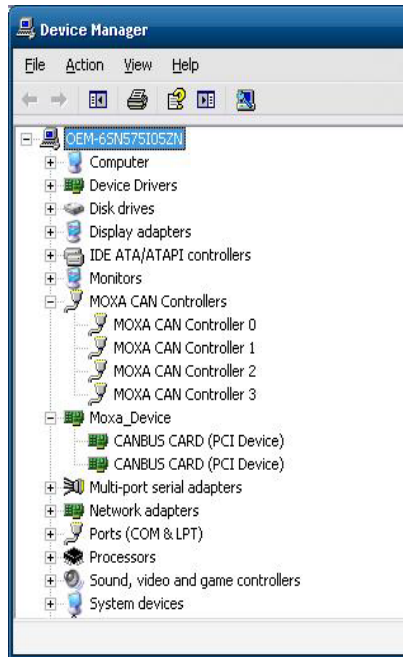

## EPM-3112: Programming Guide

### Moxa CAN Bus Library

| <b>int mxcan_close (int fd)</b> |                     |
|---------------------------------|---------------------|
| Description                     | Close an open port. |
| Input                           | <fd> the open port  |
| Return Value                    | None                |

| <b>unsigned int mxcan_get_bus_timing (int fd)</b> |  |
|---|--|
| Description                                       | Gets the bus timing of an open port.         |
| Input   | <fd> the open port                           |
| Return Value                                      | 0 on failure, otherwise the bus speed in KHz |

| <b>int mxcan_get_parameters (int fd, CANPRM * param)</b> |  |
|--|--|
| Description  | Gets the parameter of an open port.              |
| Input  | <fd> the open port                               |
| Output   | < param > pointer to the CANPRM structure        |
| Return Value   | 0 on failure, otherwise returns a negative value |

| <b>int mxcan_get_registers (int fd, unsigned char * buffer, int num)</b> |   |
|--|---|
| Description  | Gets the register values of an open port.   |
| Input  | <fd> the open port  |
| Output   | < buffer > pointer to a buffer for these values<br><num> number of register values; for a module with sja1000 chipset, the value must be 32 |
| Return Value   | 0 on success; other numbers indicate failure  |

| <b>int mxcan_get_stat (int fd, CANBST * stat)</b> |   |
|---|---|
| Description                                       | Gets the statistics of an open port.              |
| Input   | <fd> the open port                                |
| Output  | < stat > pointer to a container of the statistics |

|              |  |
|--------------|--|
| Return Value | 0 on success; other numbers indicate failure |
|--------------|--|

|                                   |  |
|-----------------------------------|--|
| <b>int mxcan_inqueue (int fd)</b> |  |
| Description                       | Gets the number of received bytes that are queued in the driver of an open port. |
| Input                             | <fd> the open port   |
| Return Value                      | 0 on failure; otherwise the number of bytes                                      |

|                                  |   |
|----------------------------------|---|
| <b>int mxcan_open (int port)</b> |   |
| Description                      | Open a can port given the port number.  |
| Input                            | <port> port number starting from 1; in Linux, open port 1 will open /dev/can0 |
| Return Value                     | -1 on failure; otherwise returns fd   |

|                                    |   |
|------------------------------------|---|
| <b>int mxcan_outqueue (int fd)</b> |   |
| Description                        | Gets the number of bytes waiting to be transmitted to a can port. |
| Input                              | <fd> the open port  |
| Return Value                       | -1 on failure; otherwise the number of bytes                      |

|  |   |
|--|---|
| <b>int mxcan_purge_buffer (int fd, unsigned int purge)</b> |   |
| Description  | Purges the buffers of an open port.                                       |
| Input  | <fd> the open port  |
| Output   | <purge> 1: received data buffer; 2: transmit data buffer; otherwise: both |
| Return Value   | 0 on success; otherwise failure   |

|   |   |
|---|---|
| <b>int mxcan_read (int fd, char * buffer, int size)</b> |   |
| Description   | Reads data into a buffer from an open port (the size should be a multiple of the CANMSG size) |
| Input   | <fd> the open port  |
| Output  | <buffer> pointer to the buffer  |
| Return Value  | 0 on failure (data not available); otherwise the number of bytes read                         |

|  |   |
|--|---|
| <b>int mxcan_set_bus_timing (int fd, unsigned int speed)</b> |   |
| Description  | Sets the bus timing of an open port.              |
| Input  | <fd> the open port                                |
| Output   | <speed> bus timing in Hz                          |
| Return Value   | 0 on success; otherwise returns a negative number |

|   |   |
|---|---|
| <b>int mxcan_set_nonblocking (int fd)</b> |   |
| Description                               | Sets the open fd to be non-blocking.              |
| Input                                     | <fd> the open port                                |
| Return Value                              | 0 on success; otherwise returns a negative number |

|  |   |
|--|---|
| <b>int mxcan_set_parameters (int fd, CANPRM * param)</b> |   |
| Description  | Sets the parameters of an open port.                          |
| Input  | <fd> the open port<br><param> pointer to the CANPRM structure |
| Output   | <speed> bus timing in Hz                                      |
| Return Value   | 0 on success; otherwise returns a negative number             |

|   |  |
|---|--|
| <b>int mxcan_set_read_timeout (int fd, unsigned int to)</b> |  |
| Description   | Sets data reading timeout of an open port.         |
| Input   | <fd> the open port<br><to> timeout in milliseconds |
| Return Value  | 0 on success; otherwise failure                    |

| <b>int mxcan_set_write_timeout (int fd, unsigned int to)</b> |  |
|--|--|
| Description  | Sets data writing timeout of an open port.         |
| Input  | <fd> the open port<br><to> timeout in milliseconds |
| Return Value   | 0 on success; otherwise failure                    |

| <b>int mxcan_write (int fd, char * buffer, int size)</b> |   |
|--|---|
| Description  | Writes data to the open port  |
| Input  | <fd> the open port<br><buffer> pointer to the data<br><size> size of the data (should be a multiple of the CANMSG size) |
| Return Value   | 0 on failure; otherwise the number of bytes written   |

## EPM-3552: Driver Installation

Take the following steps to install the EPM-3552 module driver.



### ATTENTION

The driver must be installed first. Do not install the EPM-3552 module in the computer before installing the driver.

1. Double click **DisplayLink-5.5.29194.exe** in the **Driver** folder on the software CD-ROM, and then click **I Accept** to accept the software end user license agreement.

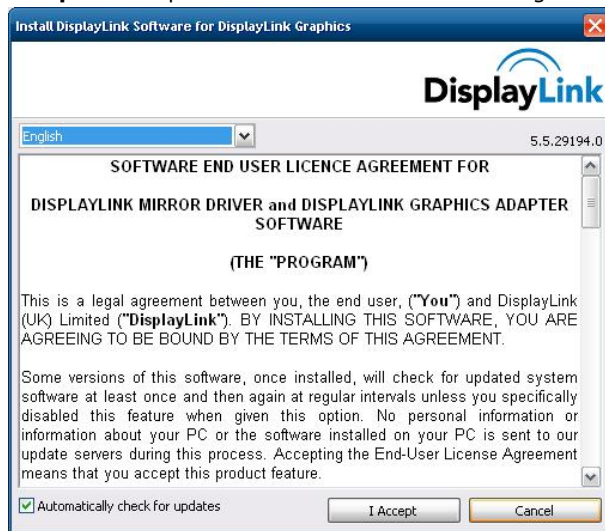

**NOTE** During the installation, You may see a message like the one below appear, and then the screen may flash or go black. Do not panic; simply wait until the process completes to continue.





- When finished, install the EPM-3552 module in your embedded computer. The following or similar message will appear on the toolbar.



- Assign a specific path for the installation driver by clicking **Browse**, and then select the following path where the driver is located:

**C:\Windows\system32\DRVStore\displaylin\_0C8028254229DB9\**

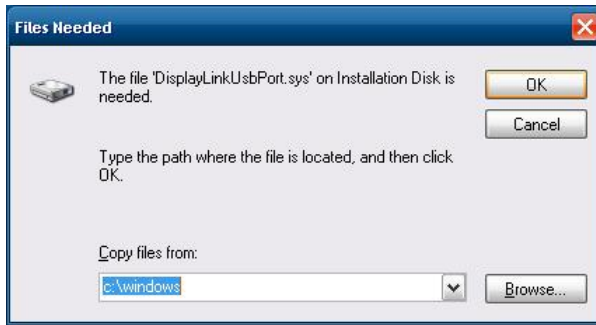

- Select **DisplayLinkUsbPort** and then click **Open**.

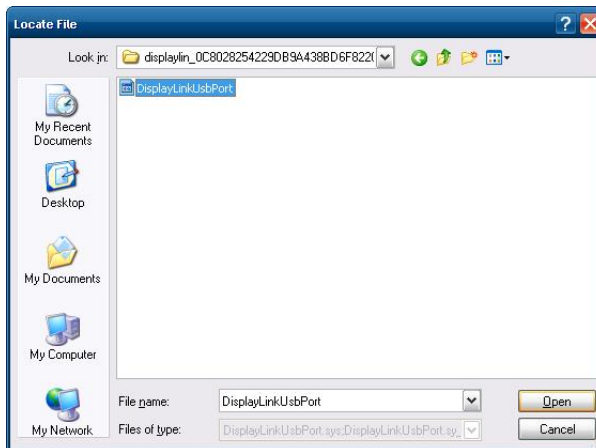

- Click **OK** to complete the installation.



**NOTE** During the installation, the screen may flash or go black.

## EPM-3552: Patch File Installation

### Known Technical Issues

The following technical issues will be apparent if you do not install the EPM-3552 patch file.

1. When powering off the V2422/2426 computer, the display connecting to an EPM-3552 module running Extended Mode also shows the shutdown screen. Normally, the display connecting to the EPM-3552 module should remain blank.
2. When the EMP-3552 module has been mounted and the V2422/2426 computer has been powered on, no image shows on the display connected to the DVI-I connector of the V2422/2426 computer. Normally, the image should be visible.

### Installing the Patch File

1. Download the patch file from <http://www.moxa.com/support>.
2. Double click **Setup.exe** to start the **Setup Wizard**, and then click **Next** to continue.

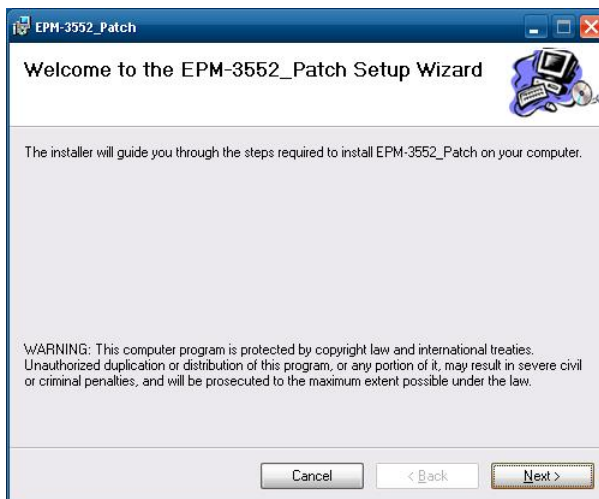

3. Click **Next** to accept the default location, and then click through the next dialog to install the patch file.



4. You will see a dialog like this, as the patch file is installed.

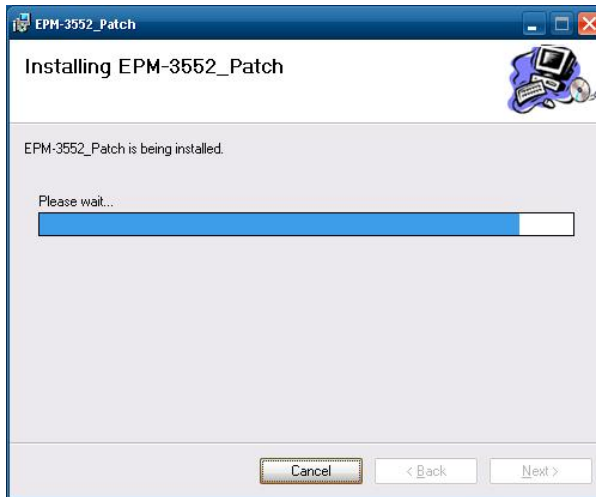

5. Click **Close** to complete the installation.



6. Restart the computer by clicking **Start → Turn Off Computer → Restart**.

## EPM-3552: Display Configuration

When the EPM-3552 module has been installed, an icon appears on the taskbar to give you access to the **DisplayLink manager menu**.

1. Click the **DisplayLink** icon on the taskbar. The menu will appear as shown below.



2. Select an option from the menu. The following table lists which options are available.

| Menu Options                | Sub-menu Options | Descriptions   |
|-----------------------------|------------------|--|
| <b>Screen Resolution</b>    |                  | Displays a list of available resolutions. Some resolutions may be enclosed by square brackets ([ ]). |
| <b>Screen Rotation</b>      | Normal           | No rotation is applied to the display.   |
|                             | Rotated Left     | Rotates the extended or mirrored display by 270 degrees.   |
|                             | Rotated Right    | Rotates the extended or mirrored display by 90 degree.   |
|                             | Upside-Down      | Rotates the extended or mirrored display by 180 degrees.   |
| <b>Extend To</b>            | Right            | Extends the display to the right of the main display.  |
|                             | Left             | Extends the display to the left of the main display.   |
|                             | Above            | Extends the display above the main display.  |
|                             | Below            | Extends the display below the main display.  |
| <b>Extent</b>               |                  | Extends your desktop onto the secondary display.   |
| <b>Set as Main Monitor</b>  |                  | Sets the secondary display as the main display.  |
| <b>Notebook Monitor Off</b> |                  | Switches off the display of an attached notebook and makes the DisplayLink display primary.          |
| <b>Mirror</b>               |                  | Copies what is on the main display and reproduces it on the secondary display.                       |
| <b>Off</b>                  |                  | Switches off the secondary display   |
| <b>Fit to TV</b>            |                  | Opens a GUI to change the size of the Windows desktop so it fits on a V screen.                      |

## EPM-3552: Configuring Extended Dual Displays

### Configuring Extended Dual Displays Using Windows Properties

1. Right-click the display and select **Properties** → **Settings**.
2. Checkmark the **Extend my windows desktop onto this computer** option.
3. Adjust the screen resolution by dragging the **Screen resolution** slide bar.
4. Select the **Color quality** from the drop-down list.
5. In the gray zone, select the monitor icons to match the physical arrangement of the monitors.
6. Click **OK** to save your settings.

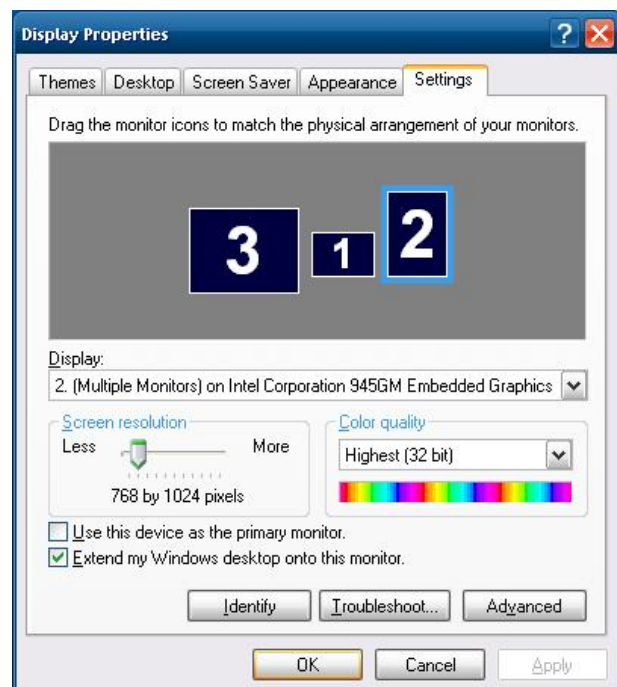

For more detailed settings, including the refresh rate, open the advanced settings dialog by clicking on the **Advanced** button in the lower right corner, then click on the **Adapter** tab and **List All Modes**. All valid combinations of resolution, color quality, and refresh rate are listed. For CRT monitors, we suggest using a high refresh rate to avoid the discomfort caused by monitor flicker. Flat panel monitors do not flicker, so a lower refresh rate is adequate. Screenshots are shown at the top of the next page.

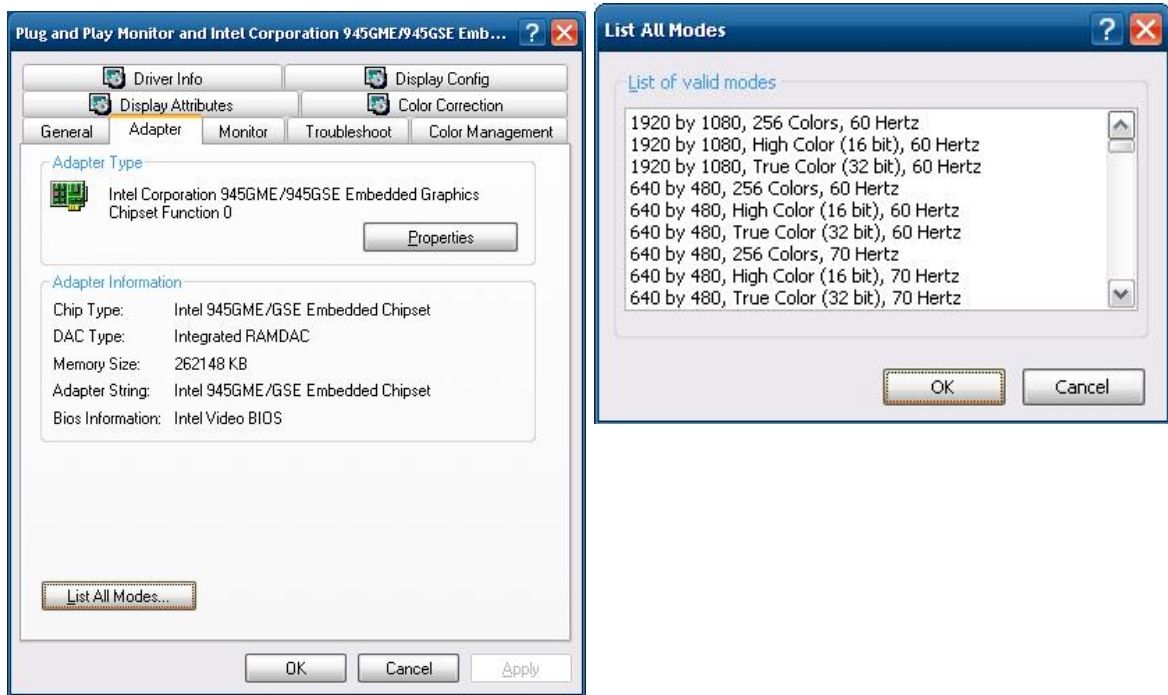

## Configuring Extended Dual Displays Using DisplayLink Properties

1. From the taskbar, click the **DisplayLink** icon. This appears as a small computer monitor.
2. Select **Extend**.

## EPM-3552: Configuring Mirrored Dual Displays

### Configuring Mirrored Dual Displays Using DisplayLink Properties

To use the Mirror Mode, you must use the **Windows Properties** dialog together with the **DisplayLink Properties** dialog. To do this:

1. Right-click anywhere on the display desktop and select **Properties**. This opens the Windows Display Properties dialog (also available under the control panel) shown at right.
2. Select the **Settings** tab, uncheck the **Extend the desktop onto this monitor** option, and click **Apply**.
3. From the taskbar, click the **DisplayLink** icon. This appears as a small computer monitor.
4. Select **Mirror** from within the DisplayLink settings dialog.

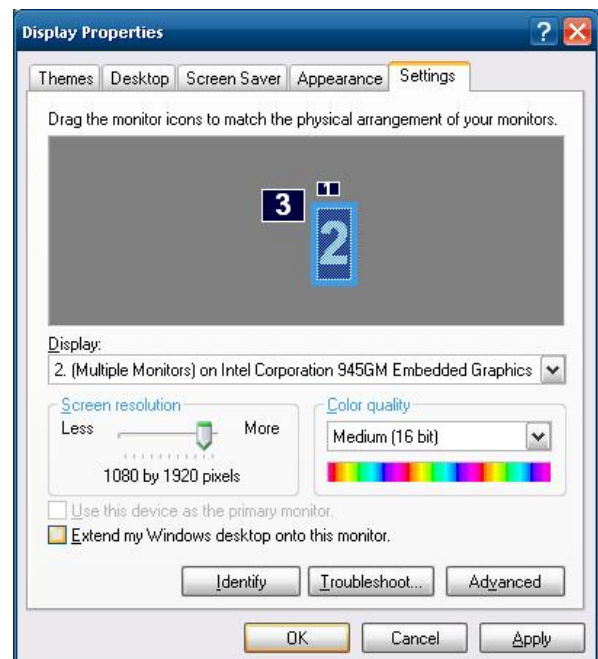

**NOTE** The display resolution of the primary display and the display may be changed to a lower resolution. In mirror mode, both screens must output the same resolution, which may not be the maximum resolution of the display. This mode is NOT recommended if you are using the display as the primary laptop display, since it is unlikely to provide the optimum resolution for the display. See **Setting the Display as the Primary Display** section for details.

## EPM-3552: Configuring a Single Primary Display

### Using Windows Properties

Take the following steps to make the display the primary display.

1. Right-click the display and then select **Properties → Settings**.
2. Checkmark the **This is my main monitor** option.
3. Uncheck the **Extend the desktop onto this monitor** option.
4. Click **Apply**.

**NOTE** On some PCs and laptops, it is necessary to disable the main display. This is because many primary graphics card drivers tend to make the laptop screen the primary screen if it is enabled. The only workaround for this is to disable the laptop screen to allow another screen to be the primary display.

To disable the main display, clear the **Extend the desktop onto this monitor** checkbox.

### Using DisplayLink Properties

1. From the taskbar, click the **DisplayLink** icon.
2. Select **Set as Main Monitor**.



## EPM-DK02: Driver Installation

1. Open the Windows **Control Panel** and click on the **Add Hardware** icon. This will open the **Add Hardware Wizard**. Click **Next** when the wizard appears.

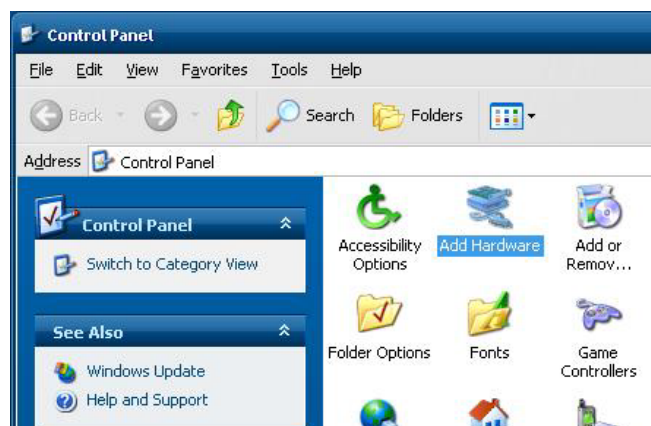

2. Select **Yes, I have already connected the hardware.**

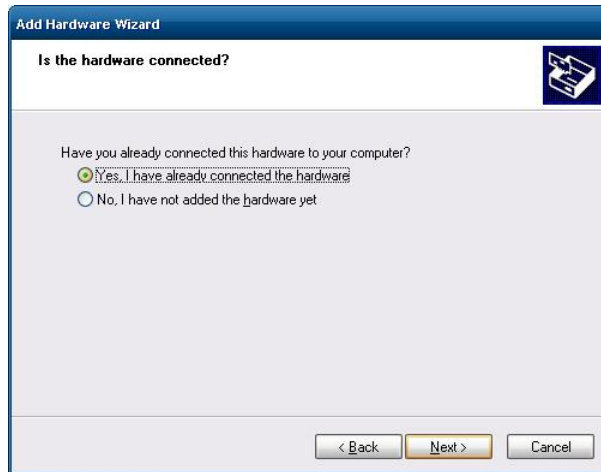

3. Select **Add a new hardware device**, and click **Next**, then select **Install the hardware that I manually select from a list (Advanced)** and click **Next**.

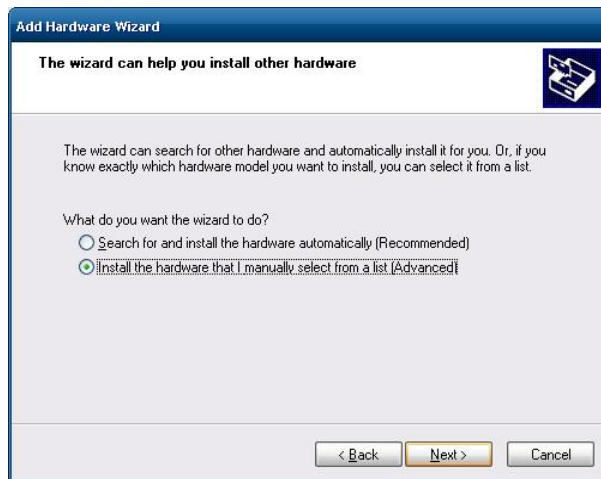

4. Select **Show All Devices** and click **Next**.

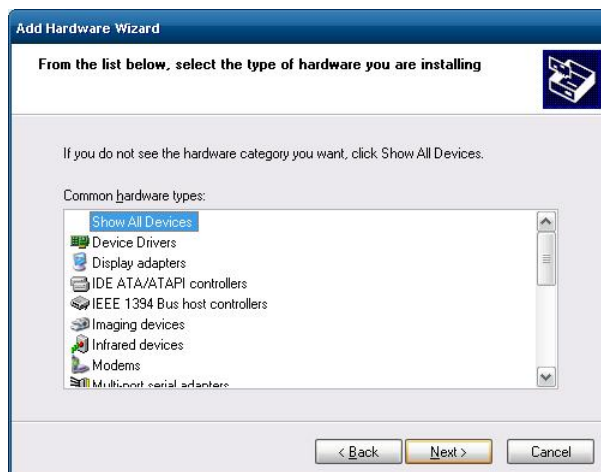

5. First, make sure the software CD that came with the module is inserted into the CD drive. Ignore the list of manufacturers and click the **Have Disk** button just under the right window.

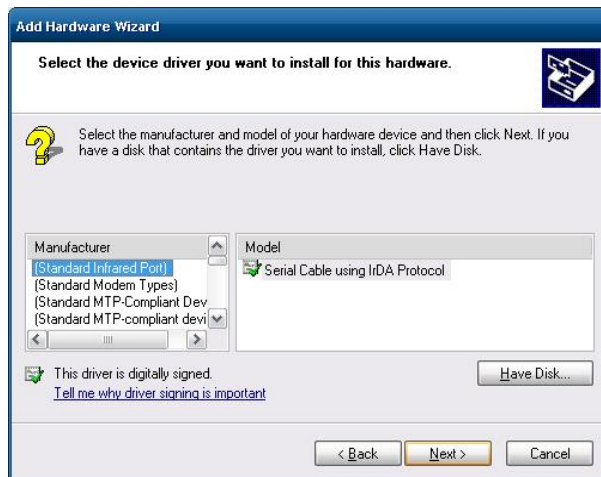

6. Select the **mxdk02.inf** from the path `D:\EPM-DK02\driver` in the CD-ROM, and click **OK**.
7. Select the **EPM-DK02 Driver** from the **Model** window and click **Next**, then Next again to install the driver.



8. Click **Finish** to complete.

## EPM-DK02: Controlling Power

The EPM-DK02 module provides a power control function that lets you control the power of a USB device so that you can enable or disable the device. This section introduces how to configure this function to enable/disable a USB DOM.

Note that the power on/off control function is only suitable for devices that have a USB interface. If you are using a device with a PCIe interface, do not enable the power on/off control function, since doing so could damage the device.

## EPM-DK02: Getting the USB Sockets' Current Power Status

1. Execute **mx-dk02-control\_mfc.exe**, located on the CD-ROM at `EPM-DK02\examples\C++\EPM-DK02_Example_Build_11060819\release`.



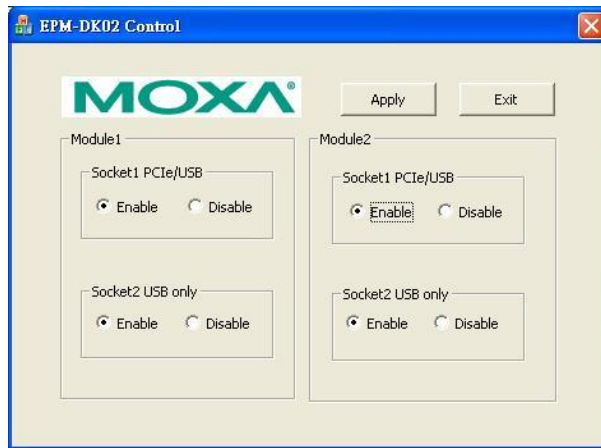

2. You may verify that the current power status for your selected devices matches that reported by the utility by checking the **Windows Device Manager**.

## EPM-DK02: Enabling/Disabling USB Socket Power

Take the following steps to disable the USB power-on socket:

1. Execute **mx-dk02-control\_mfc.exe**.
2. Select the socket and change the status.
3. Click **Apply** for the changes to take effect.
4. Check the **Windows Device Manager** to see if the device is disabled.

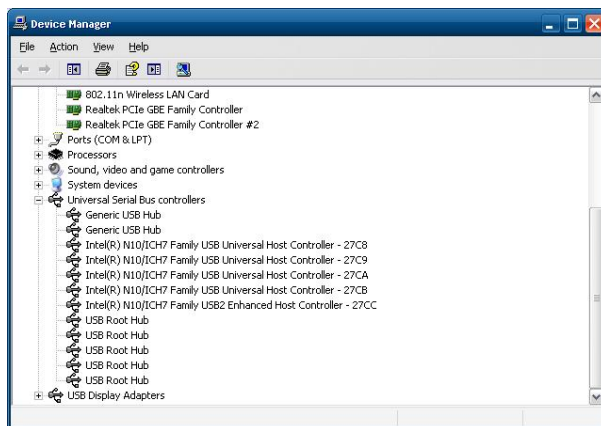

## EPM-DK03: Driver Installation

### EPM-DK03: GPS Driver Installation

Follow these steps to install GPS driver for the EMP-DK03. Please note that these are the same instructions as for the EPM-3338 module.

1. Click **Cancel** to stop searching device when you first install the module.



2. Insert the Software Package CD into the CD-ROM drive, and change driver directory to **drv\_gps**. Double-click **ublox\_A4\_U5\_USB\_drv3264\_install\_UI.exe** to install the driver.

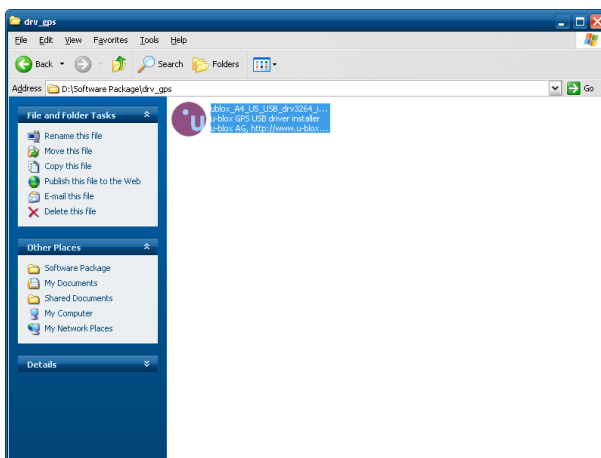

3. Select the language you want to use for the installation (default is English) and click **OK**.

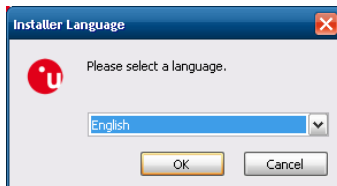

4. When the u-blox GPS driver setup wizard appears, click **Next** to continue.
5. Click **Agree** to accept the license terms.

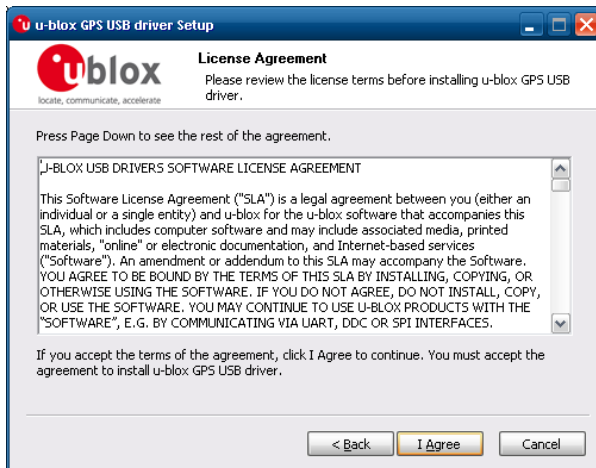

- Wait for driver installation wizard pop up. Click **Next** to begin the installation.

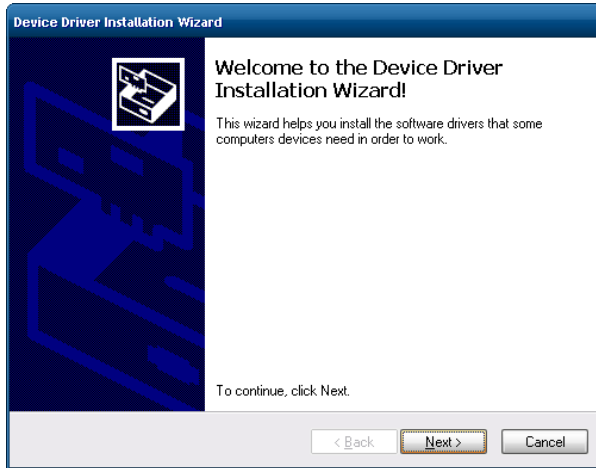

- Wait for the process to end, and when you see the image below click **Finish** to complete the installation.

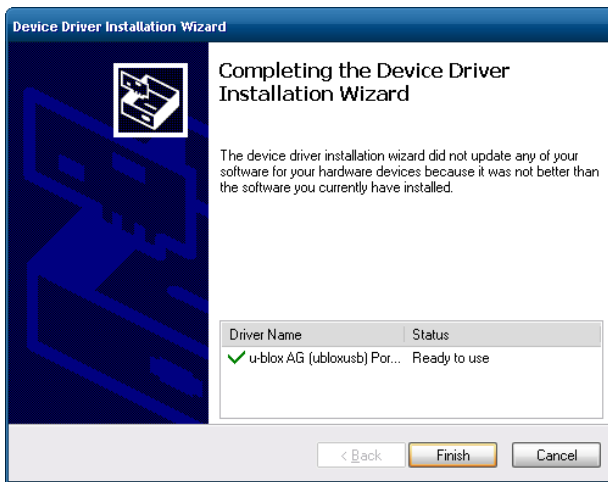

- Check the **Windows Device Manager** to verify the device is enabled. You should see an entry titled **u-blox 6 GPS Receiver**; select this and click on **Properties** to check configuration details for the GPS COM port.

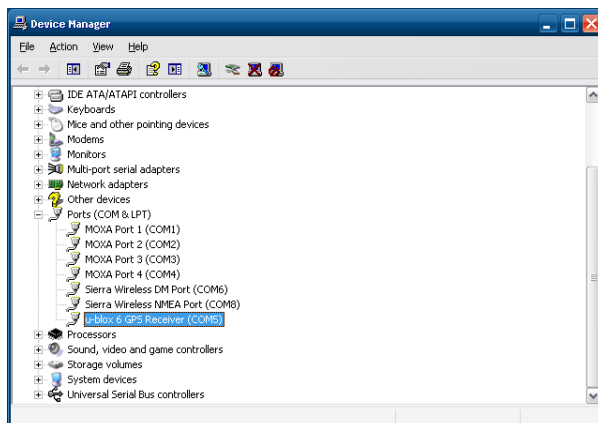

- To change the GPS receiver's port number select **Advanced** under the **Port Settings** tab.

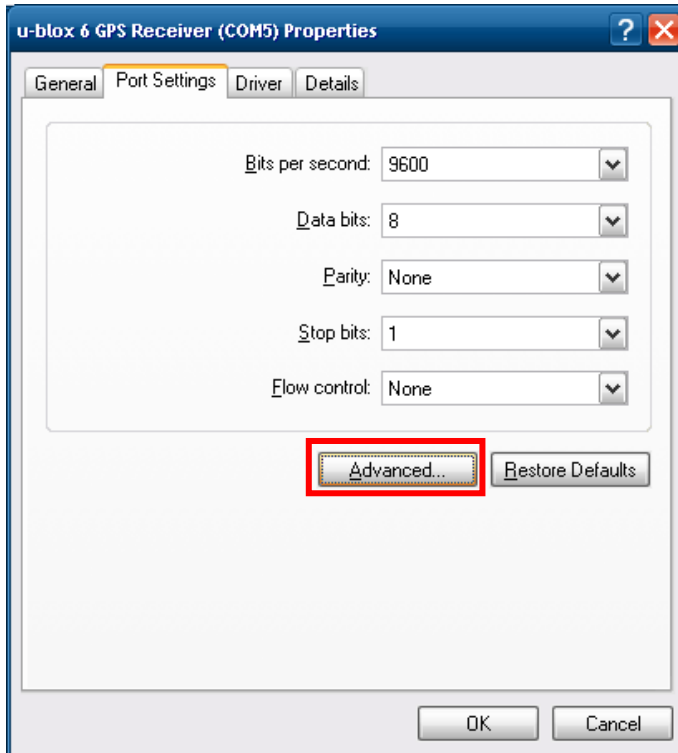

- Select your desired COM port number from the drop-down menu in the lower. Click **OK** to finish.

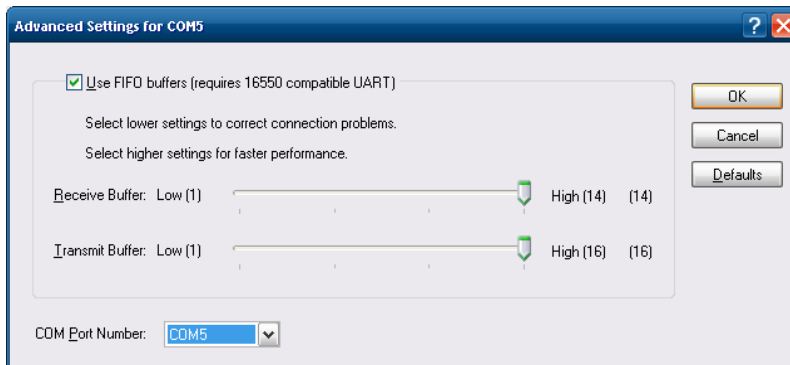

- You may now use a serial terminal like **Windows HyperTerminal** to view GPS data.

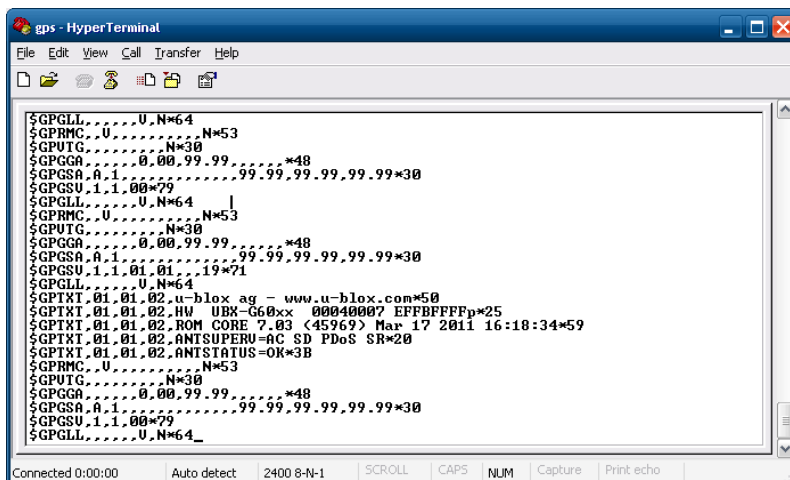

## EPM-DK03: Cellular Driver Installation

1. If the **Found New Hardware Wizard** appears, click **Cancel** to stop and exit the wizard.



2. Insert the software package CD into the CD-ROM drive, and change driver directory to `drv_Cellular\1 Driver` and double-click `DriverInst.exe` to install the driver.

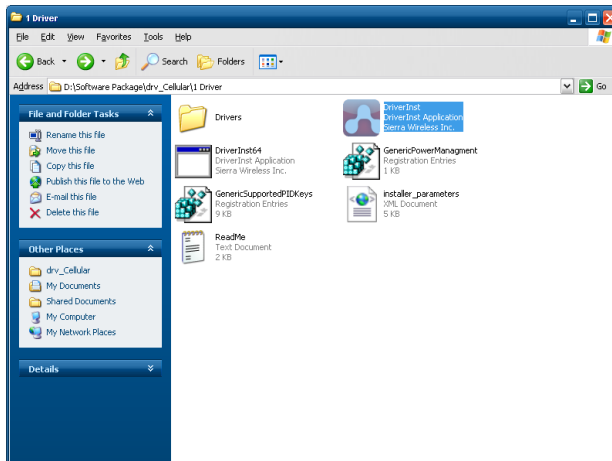

3. Wait for the new hardware to be found.

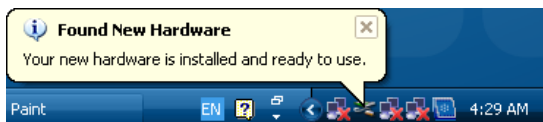

1. Change the driver directory to `drv_Cellular\2 Watcher\QMI_B3375_Watcher` and double-click `Watcher_Generic_Q.msi` to install the utility. Click **Next** to continue.



2. Select **I accept the terms in the license agreement** and click **Next** to continue.



3. Wait for the utility installation to complete, and click **Finish** to complete the installation.

## EPM-DK03: Wi-Fi Driver Installation

1. If the **Found New Hardware Wizard** appears, click **Cancel** to stop and exit the wizard.



2. Insert the software package CD into the CD-ROM drive, and navigate to the driver directory at `D:\Software Package\drv_Wi-Fi\Install_CD`. Double-click **setup.exe** to install the driver.

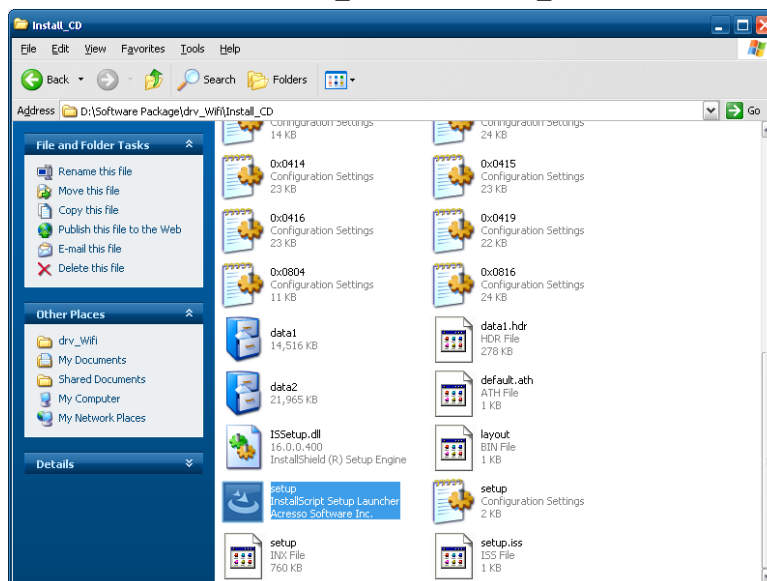

3. Select the language you want to use for the installation, and click **Next**.

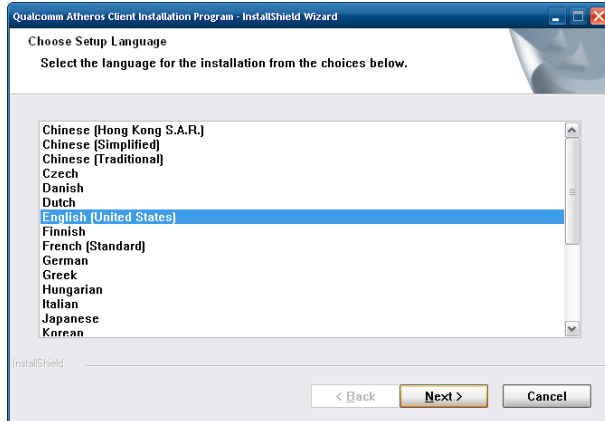

4. Wait for the driver installation to complete.  
 5. After the installation has completed, click **Next**, and then select **I accept the terms of the license agreement**, and then **Next** again to continue.

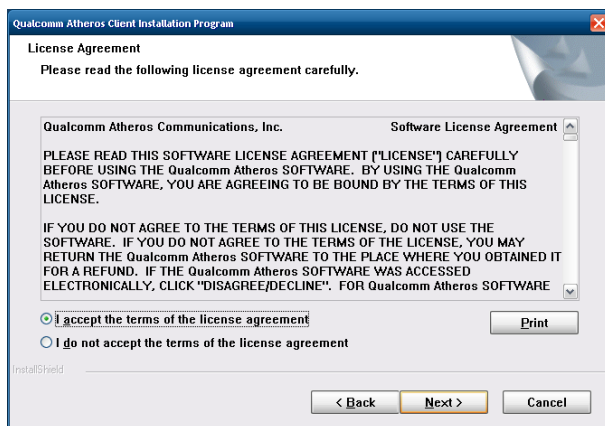

6. Select **Install Client Utilities and Driver**, and then click **Next** to continue.

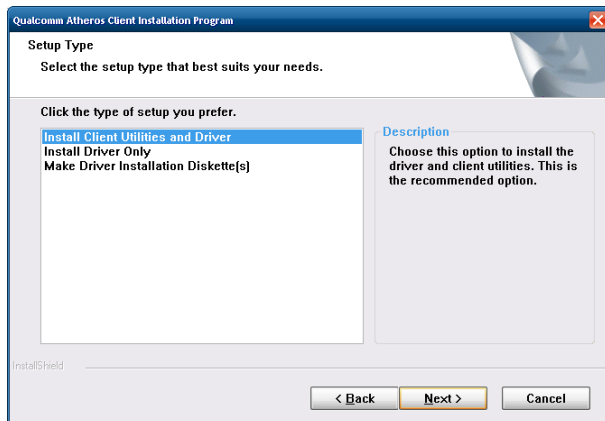

7. Verify that the file will be installed where you want it to be, and click **Next** to continue.

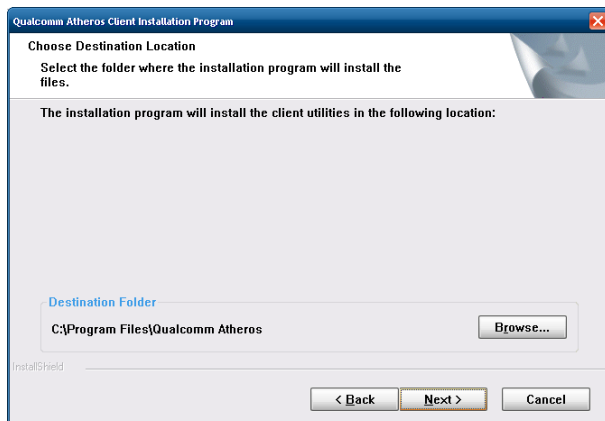

8. Select the folder in the **Windows Start Menu** where you would like to have the program startup icon filed, and click **Next**.

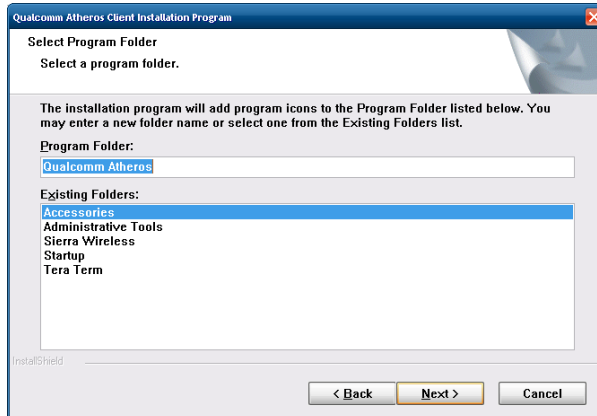

9. Click **Next** to continue to the adaptor configuration selection screen.  
 10. Select **Qualcomm Atheros Client Utility (ACU) and Supplciant**, and then click **Next** to continue.

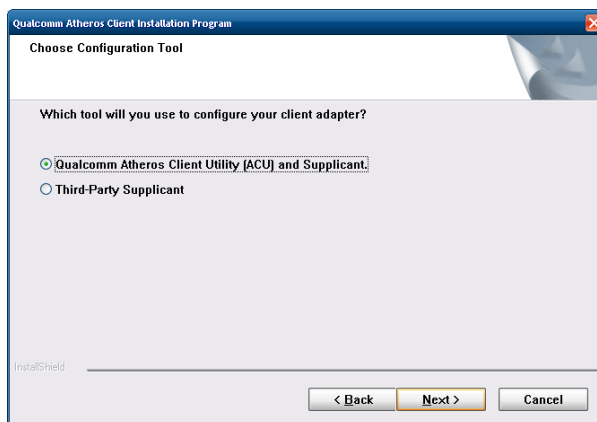

11. Click **Yes** to continue.

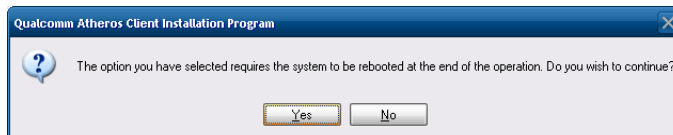

12. Wait for the installation to complete.

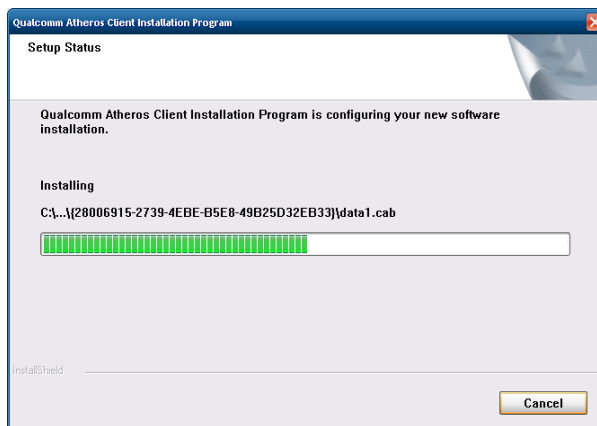

13. Select **Yes, I want to restart my computer now**, and click **Finish** to complete.  
 14. Restart the **computer** to complete the installation.

## EPM-DK03: Configuring the Cellular Software Interface

This section illustrates how to configure the cellular software interface for a wireless connection using the **Sierra Wireless AirCard Utility**.



1. Execute the program: **Start->Sierra Wireless->AirCard  
Watcher**. Click **Connect** to initiate a cellular connection. Do not close the program when the connection is established or the device driver may not work properly



2. In **Control Panel**, select **Wireless Network Connection Status**, and select **Support** tab to view the connection status. Click **Close** to complete

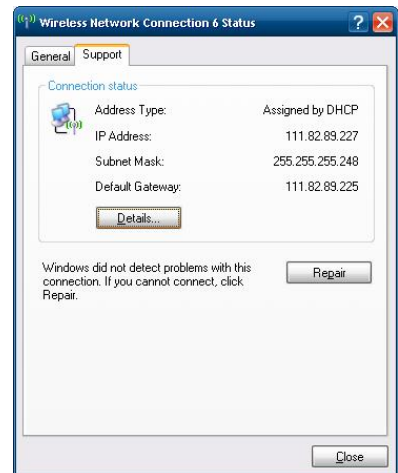

3. You may verify the cellular connection by pinging the interface once the connection is established.

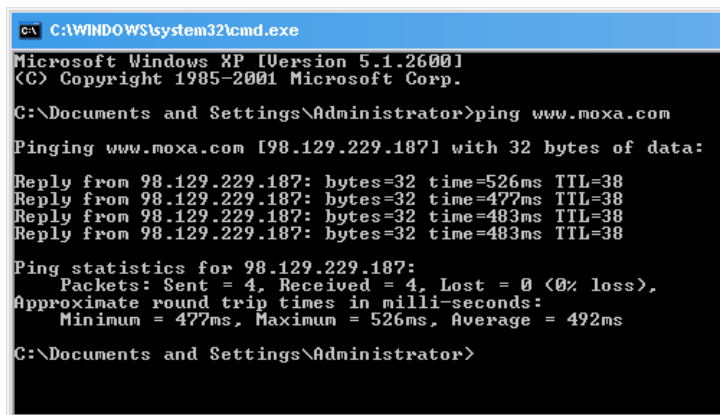

4. You may also check the connection status in **Local Area Connection Status** dialog.

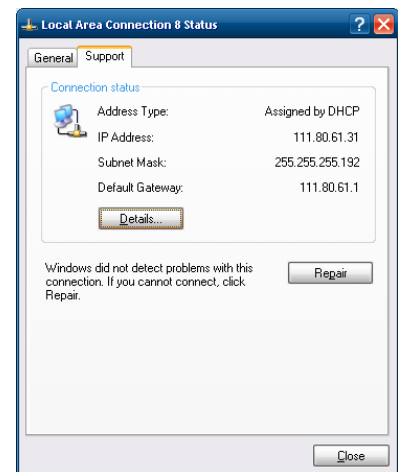

## EPM-DK03: Configuring a Wi-Fi Software Interface

This section introduces how to connect to an access point using WPA2 (RSN) encryption.



### WARNING!

**Moxa strongly advises against the use of the WEP and WPA encryption standards.** Both are now officially deprecated by the Wi-Fi Alliance, and are considered insecure. To guarantee proper Wi-Fi encryption and security, please use WPA2 with the AES encryption algorithm.

- Run the **Qualcomm Atheros Client Utility**, select the **Profile Management** tab, and click **Scan**.

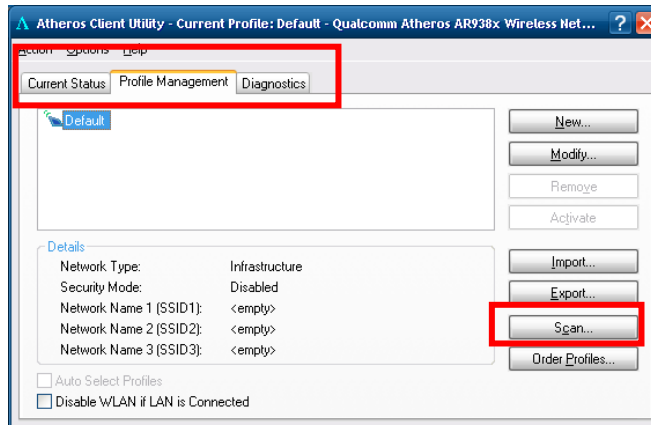

- Select the access point you want to associate with and click **Activate**.

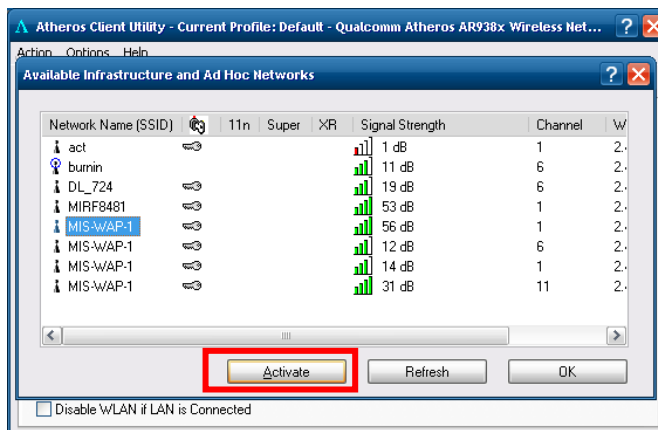

- Name this configuration profile and enter the SSIDs with which you wish this client to associate. Then change to the **Security** tab.

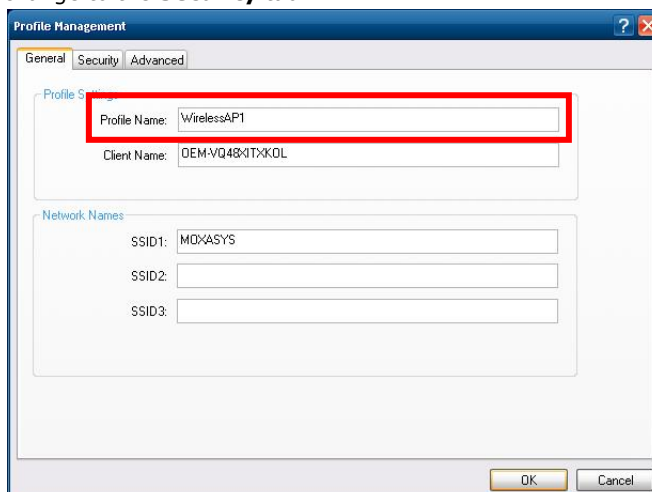

8. Moxa recommends selecting WPA2 as your security option; then click **Configure**.

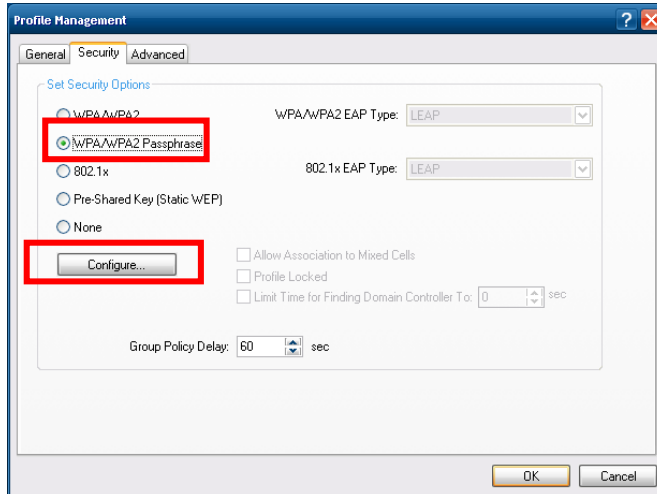

Allow Association to Mixed Cells

Check this box if the access point with which the client adapter is to associate has WEP set to optional and WEP is enabled on the client adapter. Otherwise, the client will be unable to establish a connection with the access point.

Profile Locked

This will lock the profile.

Limit Time for Finding Domain Controller to XX Seconds

Check this box and enter the number of seconds (up to 300) after which the authentication process times out when trying to find the domain controller. Entering zero is the same as disabling this feature, with no time limit enforced when searching for domain controllers.

Group Policy Delay

Specify how much time elapses before the Windows logon process starts group policy. Group policy is a Windows feature used by administrators to specify configuration options for groups of users. The objective is to delay the start of Group Policy until wireless network authentication occurs. Valid ranges are from 0 to 65535 seconds. The value that you set goes into effect after you reboot your computer with this profile set as the active profile.

This drop-down menu is active only if you choose EAP-based authentication.



**WARNING!**

**Moxa strongly advises against the use of the WEP and WPA encryption standards.** Both are now officially deprecated by the Wi-Fi Alliance, and are considered insecure. To guarantee proper Wi-Fi encryption and security, please use WPA2 with the AES encryption algorithm, and configure it with a strong passphrase.

9. Configure a strong passphrase for your WPA2 network. This may be an 8 to 63 character ASCII passphrase, or up to a 64 digit hexadecimal passphrase.

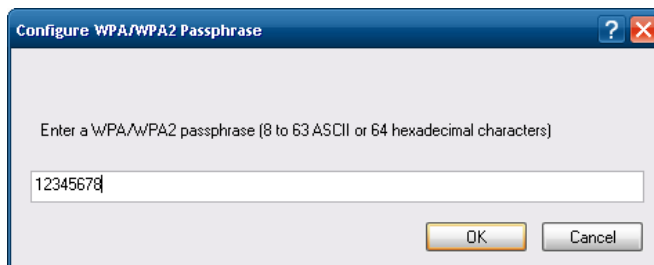

- If you want to use an Extensible Authentication Protocol, then you may choose the protocol from the drop-down boxes at the right. If you wish to use a RADIUS server, then you will need to configure your connection for 802.1X authentication. When you have configured the connection, click OK and exit the setup wizard.

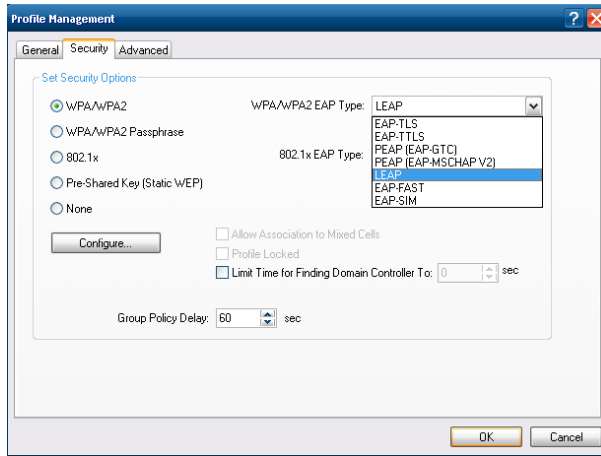

- The connection should now be established. You may check this using the **Properties** tab under the **Network Connections** icon in the **Windows Systray**.

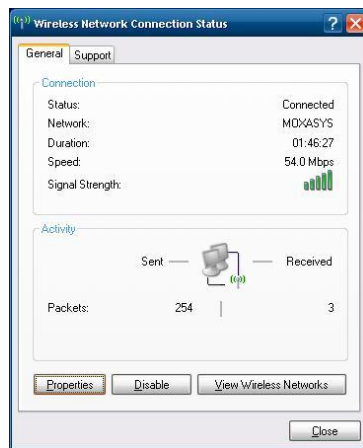

## EPM-DK03: Getting Wi-Fi Information

You may use the management utility called **Atheros Client Utility** to help get wireless connection information.

- Run the **Atheros Client Utility** on the desktop and change it to the **Current Status** tab to view the Wi-Fi connection status and information.

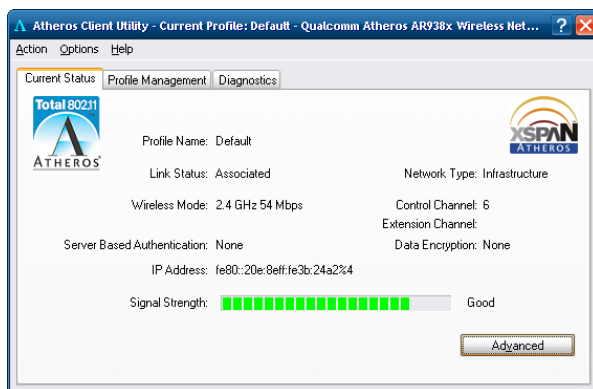

2. Click **Advanced** to view more detailed information. Click **OK** to exit.

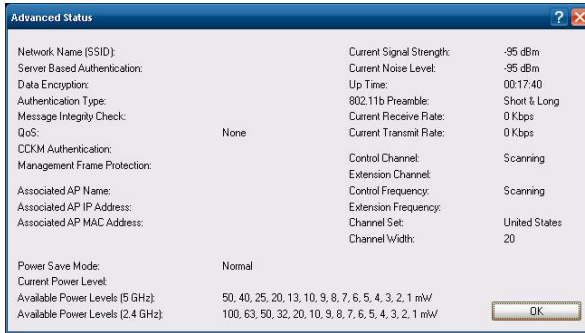

# A

## Video Performance Table for the EPM-3552 Module

The EPM-3552 is a display module that provides a VGA and DVI output function for V2422 and V2426 computers. The module is used as the additional display option apart from the VGA/DVI provided by the V2422 and V2426 computers. Moxa provides the display performance tables so that users can optimize the EPM-3552 for specific applications.

This table was produced from an actual performance test with the following parameters: video codec, audio codec, film resolution, frame per second, and bit rates. We strongly suggest that you enable the **Hyper-Threading Technology** function in the BIOS to ensure better performance of the EPM-3552 display module.

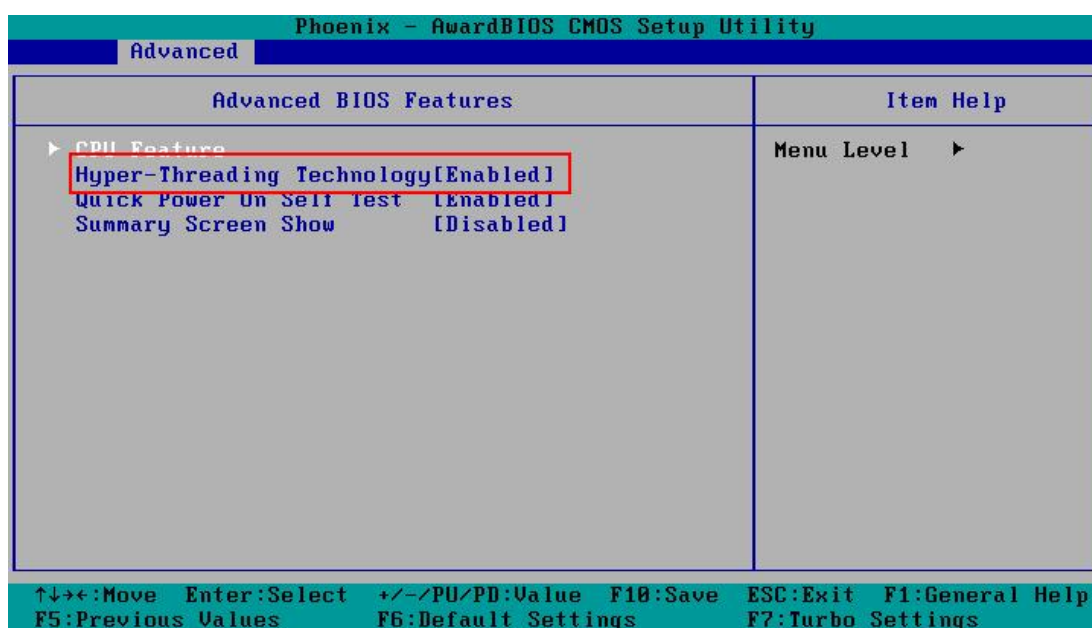

If you would like to use high resolution solutions for your applications, we suggest using the onboard VGA/DVI outputs on the V2422/2426 computers. The EPM-3552 display module is suitable for the applications that require lower resolution for displaying text and small-size figures.

# EPM-3552 Display Module Performance on Linux Systems

| Player         |           | mplayer<br>1.0rc2-4.3.2-DFSG-free |             |             |       |                | On-board<br>VGA/DVI<br>performance on<br>V24XX |                           | VGA/DVI performance on<br>EPM-3552 |                          |                         |
|----------------|-----------|-----------------------------------|-------------|-------------|-------|----------------|--|---------------------------|------------------------------------|--------------------------|-------------------------|
|                |           |                                   |             |             | Model |                | V2422/2426-LX                                  |                           | EPM-3552-LX                        |                          |                         |
|                | Container | Video Codec                       | Audio Codec | Resolution  | FPS   | BitRate (kbps) | System CPU loading                             | Media Player /CPU loading | System CPU loading                 | Media Player/CPU loading | Suggested Configuration |
| WMV3X          | WMV       | WMV3x                             | WMA9        | 1920 x 1080 | 29.97 | 15000          | 51.4   | 47.5                      | 46.6                               | 30.7                     |                         |
|                | WMV       | WMV3x                             | WMA9        | 1680 x 1050 | 29.97 | 12000          | 50.7   | 46.8                      | 48.8                               | 33                       |                         |
|                | WMV       | WMV3x                             | WMA9        | 1440 x 900  | 29.97 | 10000          | 50.1   | 46                        | 49.9                               | 33.5                     |                         |
|                | WMV       | WMV3x                             | WMA9        | 1280 x 720  | 29.97 | 8000           | 41   | 38.5                      | 45.8                               | 31.1                     |                         |
|                | WMV       | WMV3x                             | WMA9        | 1024 x 600  | 29.97 | 7000           | 29.8   | 28.4                      | 48.3                               | 33.9                     |                         |
|                | WMV       | WMV3x                             | WMA9        | 800 x 480   | 29.97 | 6000           | 20.9   | 20.1                      | 33.9                               | 23.8                     |                         |
|                | WMV       | WMV3x                             | WMA9        | 640 x 400   | 29.97 | 4000           | 14.4   | 13.7                      | 22.7                               | 16.2                     |                         |
|                | WMV       | WMV3x                             | WMA9        | 320 x 200   | 29.97 | 2000           | 6.5  | 6                         | 8.1                                | 6.5                      | ★                       |
| WMV2X          | WMV       | WMV2x                             | WMA8        | 1920 x 1080 | 29.97 | 15000          | 49.1   | 45.5                      | 46.7                               | 32.4                     |                         |
|                | WMV       | WMV2x                             | WMA8        | 1680 x 1050 | 29.97 | 12000          | 48.8   | 44.9                      | 48                                 | 33.4                     |                         |
|                | WMV       | WMV2x                             | WMA8        | 1440 x 900  | 29.97 | 10000          | 47   | 43.1                      | 48.4                               | 34                       |                         |
|                | WMV       | WMV2x                             | WMA8        | 1280 x 720  | 29.97 | 8000           | 42   | 38                        | 46.4                               | 32.5                     |                         |
|                | WMV       | WMV2x                             | WMA8        | 1024 x 600  | 29.97 | 7000           | 28.1   | 26.8                      | 44.3                               | 31.7                     | ★                       |
|                | WMV       | WMV2x                             | WMA8        | 800 x 480   | 29.97 | 6000           | 18.9   | 18                        | 29.9                               | 21.2                     | ★                       |
|                | WMV       | WMV2x                             | WMA8        | 640 x 400   | 29.97 | 4000           | 13   | 12.3                      | 20                                 | 14.2                     | ★                       |
|                | WMV       | WMV2x                             | WMA8        | 320 x 200   | 29.97 | 2000           | 6  | 5.4                       | 7.1                                | 5.6                      | ★                       |
| MPEG-2         | MPEG-PS   | MPEG-2                            | ac3         | 1920 x 1080 | 29.97 | 15000          | 43.64  | 39.2                      | 32                                 | 17.1                     |                         |
|                | MPEG-PS   | MPEG-2                            | ac3         | 1680 x 1050 | 29.97 | 12000          | 36.6   | 32.9                      | 33.7                               | 18.4                     |                         |
|                | MPEG-PS   | MPEG-2                            | ac3         | 1440 x 900  | 29.97 | 10000          | 27.9   | 25.4                      | 34.4                               | 18.8                     |                         |
|                | MPEG-PS   | MPEG-2                            | ac3         | 1280 x 720  | 29.97 | 8000           | 20.7   | 18.6                      | 31.5                               | 17.2                     |                         |
|                | MPEG-PS   | MPEG-2                            | ac3         | 1024 x 600  | 29.97 | 7000           | 15.2   | 13.6                      | 32.2                               | 17.8                     | ★                       |
|                | MPEG-PS   | MPEG-2                            | ac3         | 800 x 480   | 29.97 | 6000           | 10.9   | 9.7                       | 22.7                               | 13                       | ★                       |
|                | MPEG-PS   | MPEG-2                            | ac3         | 640 x 400   | 29.97 | 4000           | 7.6  | 6.5                       | 16.1                               | 9.1                      | ★                       |
|                | MPEG-PS   | MPEG-2                            | ac3         | 320 x 200   | 29.97 | 2000           | 3  | 2.5                       | 4.9                                | 3.1                      | ★                       |
| H.264 / MPEG-4 | MPEG-4    | H.264/M4 AVC                      | M4 AAC      | 1920 x 1080 | 29.97 | 15000          | 51.7   | 47.4                      | 41.7                               | 27.6                     |                         |
|                | MPEG-4    | H.264/M4 AVC                      | M4 AAC      | 1680 x 1050 | 29.97 | 12000          | 51.5   | 47.3                      | 44.6                               | 29.7                     |                         |
|                | MPEG-4    | H.264/M4 AVC                      | M4 AAC      | 1440 x 900  | 29.97 | 10000          | 44.7   | 42.1                      | 45.6                               | 30.2                     |                         |
|                | MPEG-4    | H.264/M4 AVC                      | M4 AAC      | 1280 x 720  | 29.97 | 8000           | 33   | 31.6                      | 42.4                               | 28.9                     |                         |
|                | MPEG-4    | H.264/M4 AVC                      | M4 AAC      | 1024 x 600  | 29.97 | 7000           | 24.5   | 23.4                      | 42.4                               | 29.1                     | ★                       |
|                | MPEG-4    | H.264/M4 AVC                      | M4 AAC      | 800 x 480   | 29.97 | 6000           | 18.2   | 17.6                      | 30.3                               | 21                       | ★                       |
|                | MPEG-4    | H.264/M4 AVC                      | M4 AAC      | 640 x 400   | 29.97 | 4000           | 12.9   | 11.9                      | 20.8                               | 14.6                     | ★                       |
|                | MPEG-4    | H.264/M4 AVC                      | M4 AAC      | 320 x 200   | 29.97 | 2000           | 5.9  | 5.5                       | 7.4                                | 5.8                      | ★                       |

|               |     |               |     |             |       |       |      |      |      |      |   |
|---------------|-----|---------------|-----|-------------|-------|-------|------|------|------|------|---|
| AVI           | AVI | MS/MPG<br>4v2 | pcm | 1920 x 1080 | 29.97 | 15000 | 48.8 | 42.7 | 35.2 | 19.9 |   |
|               | AVI | MS/MPG<br>4v2 | pcm | 1680 x 1050 | 29.97 | 12000 | 38.3 | 34.2 | 36   | 21.1 |   |
|               | AVI | MS/MPG<br>4v2 | pcm | 1440 x 900  | 29.97 | 10000 | 28.9 | 26   | 36.7 | 21.2 |   |
|               | AVI | MS/MPG<br>4v2 | pcm | 1280 x 720  | 29.97 | 8000  | 21.4 | 19.2 | 34.2 | 19.4 |   |
|               | AVI | MS/MPG<br>4v2 | pcm | 1024 x 600  | 29.97 | 7000  | 15.9 | 14.1 | 32.7 | 19.2 | ★ |
|               | AVI | MS/MPG<br>4v2 | pcm | 800 x 480   | 29.97 | 6000  | 10.6 | 9.4  | 22.6 | 13.2 | ★ |
|               | AVI | MS/MPG<br>4v2 | pcm | 640 x 400   | 29.97 | 4000  | 7.2  | 6.1  | 15.4 | 8.8  | ★ |
|               | AVI | MS/MPG<br>4v2 | pcm | 320 x 200   | 29.97 | 2000  | 2.74 | 2    | 4.4  | 2.6  | ★ |
| AVI<br>(DivX) | AVI | DivX-5        | mp3 | 1920 x 1080 | 29.97 | 15000 | 49.1 | 42.6 | 35.8 | 20.4 |   |
|               | AVI | DivX-5        | mp3 | 1680 x 1050 | 29.97 | 12000 | 37.9 | 34.4 | 36.8 | 21.4 |   |
|               | AVI | DivX-5        | mp3 | 1440 x 900  | 29.97 | 10000 | 28.6 | 26.1 | 36.9 | 21.7 |   |
|               | AVI | DivX-5        | mp3 | 1280 x 720  | 29.97 | 8000  | 21.5 | 19.6 | 34   | 20   |   |
|               | AVI | DivX-5        | mp3 | 1024 x 600  | 29.97 | 7000  | 15.9 | 14.2 | 33.8 | 20   | ★ |
|               | AVI | DivX-5        | mp3 | 800 x 480   | 29.97 | 6000  | 10.9 | 9.8  | 23   | 13.6 | ★ |
|               | AVI | DivX-5        | mp3 | 640 x 400   | 29.97 | 4000  | 7.5  | 6.6  | 16   | 9.3  | ★ |
|               | AVI | DivX-5        | mp3 | 320 x 200   | 29.97 | 2000  | 3.2  | 2.8  | 5    | 3.4  | ★ |

## EPM-3552 Display Module Performance on Windows Systems

| Player          |                | Media Player Classic - Home Cinema<br>v1.4.1.2834 |             |       |                   | On-board VGA/DVI<br>performance on V24XX |                              | VGA/DVI performance on<br>EPM-3552 |                                |                            |
|-----------------|----------------|---|-------------|-------|-------------------|--|------------------------------|------------------------------------|--------------------------------|----------------------------|
| Film Parameters |                |   |             |       |                   | V2422/V2426-XPE                          |                              | EPM-3552                           |                                |                            |
| Container       | Video<br>Codec | Audio<br>Codec                                    | Resolution  | FPS   | BitRate<br>(KBS/) | System<br>CPU<br>loading                 | Media Player<br>/CPU loading | System<br>CPU<br>loading           | Media<br>Player/CPU<br>loading | Suggested<br>Configuration |
| WMV             | WMV3x          | WMA9  | 1920 x 1080 | 29.97 | 15000             | 52.4                                     | 50.6                         | 95.9                               | 47.8                           |                            |
| WMV             | WMV3x          | WMA9  | 1680 x 1050 | 29.97 | 12000             | 52                                       | 50.1                         | 96.7                               | 48.5                           |                            |
| WMV             | WMV3x          | WMA9  | 1440 x 900  | 29.97 | 10000             | 50.1                                     | 48.4                         | 92.7                               | 47.9                           |                            |
| WMV             | WMV3x          | WMA9  | 1280 x 720  | 29.97 | 8000              | 37.7                                     | 35.7                         | 90.4                               | 46.6                           |                            |
| WMV             | WMV3x          | WMA9  | 1024 x 600  | 29.97 | 7000              | 29.2                                     | 27.7                         | 74.9                               | 35.8                           |                            |
| WMV             | WMV3x          | WMA9  | 800 x 480   | 29.97 | 6000              | 23.1                                     | 21.6                         | 67                                 | 26.3                           | ★                          |
| WMV             | WMV3x          | WMA9  | 640 x 400   | 29.97 | 4000              | 23.5                                     | 21.9                         | 53.6                               | 22                             | ★                          |
| WMV             | WMV3x          | WMA9  | 320 x 200   | 29.97 | 2000              | 10.5                                     | 9                            | 23.1                               | 10.7                           | ★                          |
| WMV             | WMV2x          | WMA8  | 1920 x 1080 | 29.97 | 15000             | 48.1                                     | 46.9                         | 92.5                               | 47.2                           |                            |
| WMV             | WMV2x          | WMA8  | 1680 x 1050 | 29.97 | 12000             | 46.1                                     | 44.8                         | 91.8                               | 46.4                           |                            |
| WMV             | WMV2x          | WMA8  | 1440 x 900  | 29.97 | 10000             | 38.1                                     | 36.4                         | 86.1                               | 44.8                           |                            |
| WMV             | WMV2x          | WMA8  | 1280 x 720  | 29.97 | 8000              | 29.4                                     | 28                           | 75.7                               | 36.4                           |                            |
| WMV             | WMV2x          | WMA8  | 1024 x 600  | 29.97 | 7000              | 21.2                                     | 19.7                         | 63.9                               | 25.3                           | ★                          |
| WMV             | WMV2x          | WMA8  | 800 x 480   | 29.97 | 6000              | 19.3                                     | 17.9                         | 57                                 | 19.2                           | ★                          |
| WMV             | WMV2x          | WMA8  | 640 x 400   | 29.97 | 4000              | 17.6                                     | 16.2                         | 47.4                               | 19.6                           | ★                          |
| WMV             | WMV2x          | WMA8  | 320 x 200   | 29.97 | 2000              | 8.1                                      | 6.7                          | 19.5                               | 8.3                            | ★                          |



|         |              |        |             |       |       |      |      |      |      |   |
|---------|--------------|--------|-------------|-------|-------|------|------|------|------|---|
| MPEG-PS | MPEG-2       | ac3    | 1920 x 1080 | 29.97 | 15000 | 42.6 | 40.9 | 95.4 | 47.4 |   |
| MPEG-PS | MPEG-2       | ac3    | 1680 x 1050 | 29.97 | 12000 | 36.2 | 34.7 | 94.5 | 46.4 |   |
| MPEG-PS | MPEG-2       | ac3    | 1440 x 900  | 29.97 | 10000 | 28.1 | 26.7 | 80.4 | 34   | ★ |
| MPEG-PS | MPEG-2       | ac3    | 1280 x 720  | 29.97 | 8000  | 21.7 | 20.1 | 68.8 | 24.9 | ★ |
| MPEG-PS | MPEG-2       | ac3    | 1024 x 600  | 29.97 | 7000  | 17   | 15.5 | 60.5 | 19.2 | ★ |
| MPEG-PS | MPEG-2       | ac3    | 800 x 480   | 29.97 | 6000  | 12.8 | 11.6 | 54.6 | 14.1 | ★ |
| MPEG-PS | MPEG-2       | ac3    | 640 x 400   | 29.97 | 4000  | 9.6  | 8.3  | 39.6 | 10.8 | ★ |
| MPEG-PS | MPEG-2       | ac3    | 320 x 200   | 29.97 | 2000  | 5.3  | 3.9  | 16.7 | 5.8  | ★ |
| MPEG-4  | H.264/M4 AVC | M4 AAC | 1920 x 1080 | 29.97 | 15000 | 54.3 | 51.8 | 91.7 | 44.4 |   |
| MPEG-4  | H.264/M4 AVC | M4 AAC | 1680 x 1050 | 29.97 | 12000 | 43.9 | 43.1 | 93.1 | 45.2 |   |
| MPEG-4  | H.264/M4 AVC | M4 AAC | 1440 x 900  | 29.97 | 10000 | 36.6 | 35.1 | 85.4 | 41.4 |   |
| MPEG-4  | H.264/M4 AVC | M4 AAC | 1280 x 720  | 29.97 | 8000  | 28.5 | 26.8 | 77.6 | 34.2 | ★ |
| MPEG-4  | H.264/M4 AVC | M4 AAC | 1024 x 600  | 29.97 | 7000  | 21.8 | 20.3 | 67   | 26.1 | ★ |
| MPEG-4  | H.264/M4 AVC | M4 AAC | 800 x 480   | 29.97 | 6000  | 16.5 | 15   | 60.5 | 19.1 | ★ |
| MPEG-4  | H.264/M4 AVC | M4 AAC | 640 x 400   | 29.97 | 4000  | 11.9 | 10.4 | 43.5 | 14.2 | ★ |
| MPEG-4  | H.264/M4 AVC | M4 AAC | 320 x 200   | 29.97 | 2000  | 6.7  | 5.1  | 17.9 | 6.2  | ★ |
| AVI     | MS/MPG4v2    | pcm    | 1920 x 1080 | 29.97 | 15000 | 51.8 | 50.1 | 94.2 | 48.3 |   |
| AVI     | MS/MPG4v2    | pcm    | 1680 x 1050 | 29.97 | 12000 | 51.4 | 49.9 | 92.7 | 48   |   |
| AVI     | MS/MPG4v2    | pcm    | 1440 x 900  | 29.97 | 10000 | 51.4 | 49.6 | 89.6 | 47.8 |   |
| AVI     | MS/MPG4v2    | pcm    | 1280 x 720  | 29.97 | 8000  | 50.6 | 49.1 | 88.2 | 47.8 |   |
| AVI     | MS/MPG4v2    | pcm    | 1024 x 600  | 29.97 | 7000  | 36.4 | 35   | 78.4 | 40.8 |   |
| AVI     | MS/MPG4v2    | pcm    | 800 x 480   | 29.97 | 6000  | 24.9 | 23.4 | 67.7 | 27.2 | ★ |
| AVI     | MS/MPG4v2    | pcm    | 640 x 400   | 29.97 | 4000  | 17.1 | 15.5 | 48.9 | 18.2 | ★ |
| AVI     | MS/MPG4v2    | pcm    | 320 x 200   | 29.97 | 2000  | 6.1  | 4.6  | 17   | 5.4  | ★ |
| AVI     | DivX-5       | mp3    | 1920 x 1080 | 29.97 | 15000 | 47.9 | 46.3 | 78.5 | 34.4 |   |
| AVI     | DivX-5       | mp3    | 1680 x 1050 | 29.97 | 12000 | 41.8 | 39.9 | 81.3 | 36.6 |   |
| AVI     | DivX-5       | mp3    | 1440 x 900  | 29.97 | 10000 | 33.5 | 31.9 | 85.7 | 41.1 |   |
| AVI     | DivX-5       | mp3    | 1280 x 720  | 29.97 | 8000  | 27.1 | 25.4 | 74.6 | 32.2 | ★ |
| AVI     | DivX-5       | mp3    | 1024 x 600  | 29.97 | 7000  | 19.7 | 18.2 | 64.6 | 23.3 | ★ |
| AVI     | DivX-5       | mp3    | 800 x 480   | 29.97 | 6000  | 14.9 | 13.2 | 56.8 | 16.6 | ★ |
| AVI     | DivX-5       | mp3    | 640 x 400   | 29.97 | 4000  | 10.9 | 9.4  | 39.8 | 12.5 | ★ |
| AVI     | DivX-5       | mp3    | 320 x 200   | 29.97 | 2000  | 6.4  | 4.9  | 17.1 | 5.6  | ★ |